

Education Statistics Annual Abstract

1994 E.C. /2001-02/



Crude Enrollment Ratio in Primary (1-3)

TVET Enrollment

Higher Education Enrollment

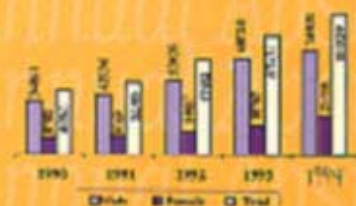
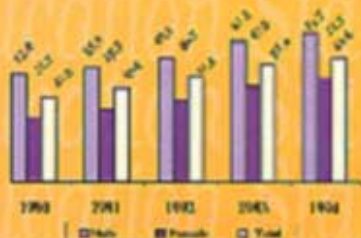

Education Management Information Systems
Ministry of Education
September 2002
Abstr. Abstr., Fih 1994

EDUCATION STATISTICS

ANNUAL ABSTRACT

1994 E.C. /2001-02/



Education Management Information Systems

Ministry of Education

September 2002

Addis Ababa

Table of Contents

	Contents	Page
1.	Introduction	1
2.	Summary Tables	23
3.	Education Budget	44
4.	Kindergarten School	45
5.	General Education	46
	5.1 Enrollment by Grade	46
	5.2 Repeaters by Grade	56
	5.3 Sections	60
	5.4 Teachers	64
	5.5 Schools	79
	5.6 Facilities	83
6.	Flow Rates	90
7.	Teachers Training Institution (TTI)	97
8.	Technical and Vocational Education and Training	98
	8.1 Enrollment by Region	98
	8.2 Teachers	99
	8.3 Students Enrolled by Occupation Title	101
9.	Higher Education	107
	9.1 Institution of Higher Education	108
	9.2 Summary Tables	109
	9.3 Enrollment	112
	9.4 Readmission	122
	9.5 Graduates	127
	9.6 Teaching Staff	133
	9.7 Administrative Staff	160
	9.8 Scholarship Students	165
	9.9 Recurrent Budget	167
	9.10 Continuing Education	168

INTRODUCTION

Education plays a significant role in reducing poverty and enhancing the development of society. Realizing this fact, the Government of Ethiopia gives high priority to the education sector. However, low enrolment, high gender and regional disparity and low quality of education have been the major challenges of the Ethiopian Education System for a long period of time. In order to redress those underserved situations, the Ethiopian Government has adopted a new Education and Training Policy (ETP) along with its Sector Strategy in 1994.

The Education and Training Policy outlined the mission and goals for the education system of Ethiopia to achieve the present and future national economic and social development goals. The policy focuses on increasing access to educational opportunities with enhanced equity, quality and relevance. This was the basis for the multi-year Education Sector Development Program (ESDP) that started in 1997/98 with the long-term goal of achieving universal primary education by the year 2015.

The first five year Education Sector Development Program (ESDP I) is concluded in the last Ethiopian Fiscal Year, July 7, 2002. ESDP I has set the target that should be reached by the end of the program period. Its progress has been monitored using the data provided in the Education Statistics Annual Abstracts that preceded this publication. Similarly, this Education Statistics Annual Abstract will help to measure the extent to which those program targets are achieved in the last five years.

Currently the second Education Sector Development Program (ESDP II) is under implementation since July 8, 2002. In order to synchronize with the life term of the Government, ESDP II shall span for three years, from 2002/03 to 2004/05.

The source of information for this Abstract (similar to the previous ones) are annual school censuses carried out by regional education bureaus through standard questionnaires designed to collect data from each school. The main purpose of this publication, as others, is to provide relevant, reliable and up to date data on education. In addition to measuring the progress of ESDP I, the 1994 E.C. (2001/02) Education Statistics Annual Abstract can also be used as source of information for the various stakeholders in the education sector, especially for the purposes of research, planning and policy formulation both at regional and national levels.

This publication has three main parts: General Education, Technical and Vocational Education and Training and Higher Education. Time series data on enrolment, teachers, sections and schools for the last five years are included to see trends and make comparison among regions. This abstract has also included enrolment in evening programs in primary and secondary schools to estimate the GER.

The Abstract mainly encompasses data on basic variables at all levels of education ranging from kindergarten to higher education. The publication contains both descriptive and analytical summary on enrolment, teachers, sections, schools, etc. The data are further disaggregated by level of education, sex, type, region, urban and rural areas in order to see regional, urban/rural and gender disparities.

Due to lack of complete information, the education data for Somali Region (except enrollments and number of schools) are taken from 1993 E.C data.

The education data that are presented in this publication are by no means considered exhaustive. It is believed that further inclusion and refinement have to be done continuously. To this effect, Ministry of Education is working on the improvement of the quality and coverage of the education statistics and there will be a continuous effort to produce better and timely information.

Educational Indicators

Educational indicators play an important role in providing a clear picture of the performance of the education system. Since indicators can be used by policy makers, planners, and other stakeholders for different purposes, it is very important to have them timely. However, it should be noted that a single indicator may not be enough to give a full picture of a certain phenomenon and thus the use of two or more indicators in combination will maximize the power of the indicators to explain a given situation.

As used to be in the past, few indicators that are assumed to be most important for the majority of the stakeholders in education are presented in this publication. The detailed indicators will be given in the “ Indicators of the Ethiopian Education System: Quick Reference” booklet.

The main sources of data for the preparation of those indicators are the statistics in this Abstract and population projection of Central Statistical Authority's (CSA).

The CSA population projection that is given in five years age group at five years interval is disaggregated using the Beers Coefficient Multiplier Method in order to arrive at single age population for each year and there by to estimate the school age population data of each region. The total projected population of Ethiopia for the year 1994 E.C. (2001/02) is 65,344,767 out of which 49.84% are females and 50.16% are males.

Access

Enrollment in Kindergartens

This level normally includes children of age 4-6 enrolled in the pre-primary education. Non-government organizations, communities, missions, private individuals, religious institutions, etc run kindergartens. The Government does not run a pre-school program. However, it develops curriculum, trains teachers and provides supervision support. The number of these schools is increasing every year, particularly in urban areas.

Gross enrollment rate at kindergarten level: This is defined as the proportion of total number of children in kindergarten, irrespective of age to total population of age 4-6.

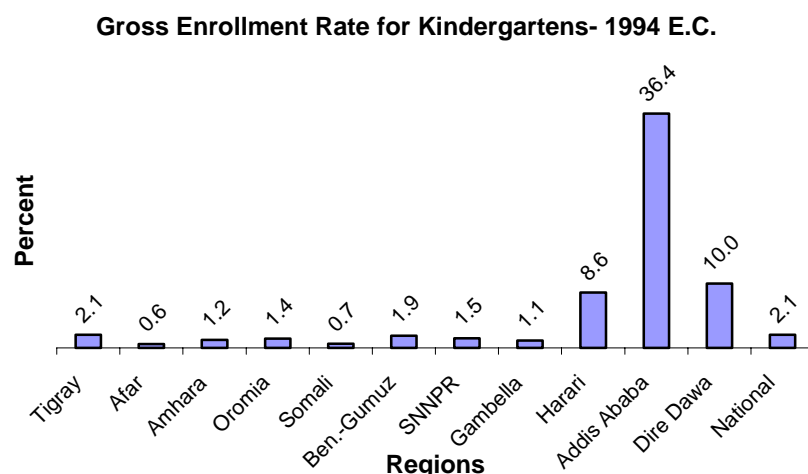

In 1994 E.C. about 118,986 children in 1189 kindergartens have been reported to have access to pre-primary education out of the estimated total 5,799,181 children of the

appropriate age group. This figure is around 8.8 % higher than the previous year. Since, the data at this level does not cover all schools (Some NGO's schools are not captured), total enrollment could be a little higher than the figure indicated above.

In 1994 E.C. the GER for kindergarten is 2.1% exhibiting only an increase of 0.1% from the pervious year.

Addis Ababa has the highest GER at this level, 36.4%, followed by Dire Dawa (10.0%) and Harari (8.6%). Tigray has an enrollment rate that is equal to the national average while other regions have a GER less than the national average, 2.1%.

Gross Enrollment rate at primary (1-8) level: This is probably the most widely used indicator of access or participation in developing countries. It is the proportion of total enrollment in primary, irrespective of age, out of the corresponding primary school age population.

GER is a crude measure of coverage. Usually it includes under aged or over-aged pupils and as a result it can be higher than 100%. Normally, the age of students in grades 1-8 has to be in the range of 7-14 and the starting age at grade 1 is seven.

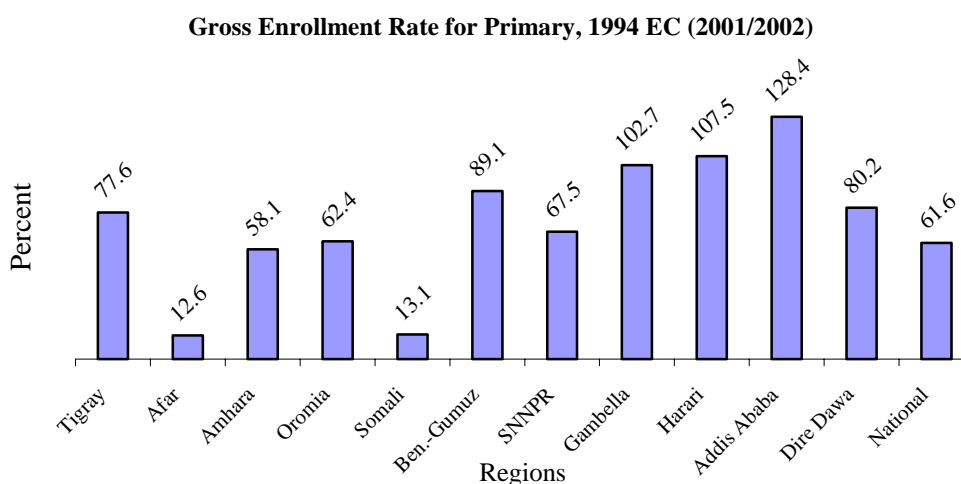

In 1994 E.C. the primary school (grade 1-8) age population is estimated to be 13,221,547; of this 8,144,337 were enrolled in regular and evening programs of the primary education.

This year the primary GER at national level is 61.6%, and when disaggregated by gender, it is 51.2% for girls and 71.7% for boys. Compared to the previous year (1993

E.C.), these figures show an increase of 4.2 and 4.4 percentage points for girls and boys respectively.

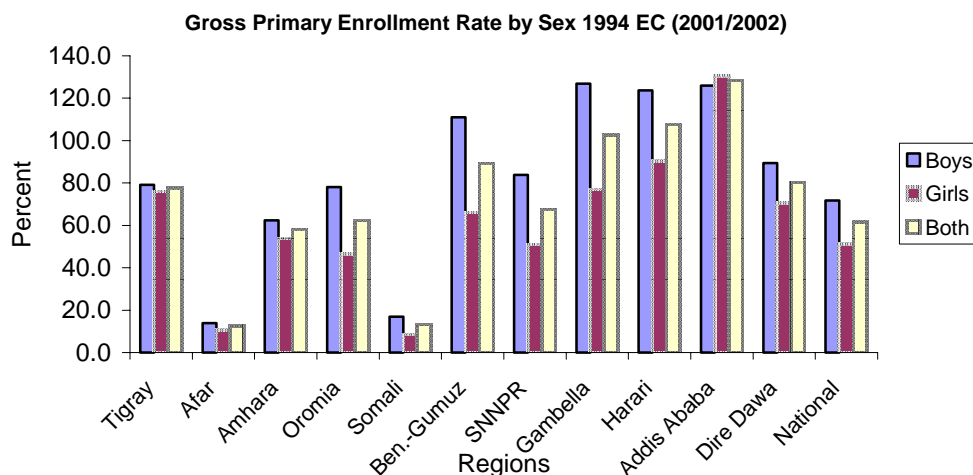

Compared to 1993 E.C., the national GER for primary (1-8) has increased by 4.2 percentage points and of the total GER (61.6%), 1.2% (161,577) is contributed by the evening program.

At regional level, Addis Ababa (128.4%) has the highest participation rate while Afar region has the lowest (12.6%). In terms of girls' participation (GER), Addis Ababa achieved the highest, 130.5% and Somali Region the lowest 9.5%.

Net enrollment rate (NER) at primary (1-8) level

NER is the best way of measuring participation and is a more refined indicator of coverage in terms of explaining the proportion of pupils enrolled from a specific age group. However, in our case it may be less reliable since the age specific data we get from schools are sometimes questionable. The NER is usually lower than the GER as it excludes over-aged and under-aged pupils while using the same denominator as the GER.

The NER for regular students for the year 2001/02 is 52.2%. The number of students in evening program is excluded from the calculation due to lack of data classified by age for this program. Otherwise, it is clear that the NER would have been higher than the figure indicated here. The five years data on primary net enrolment rate shows an

increasing trend as the GER does. When disaggregated by gender the NER is 45.2% for girls and 59.0% for boys.

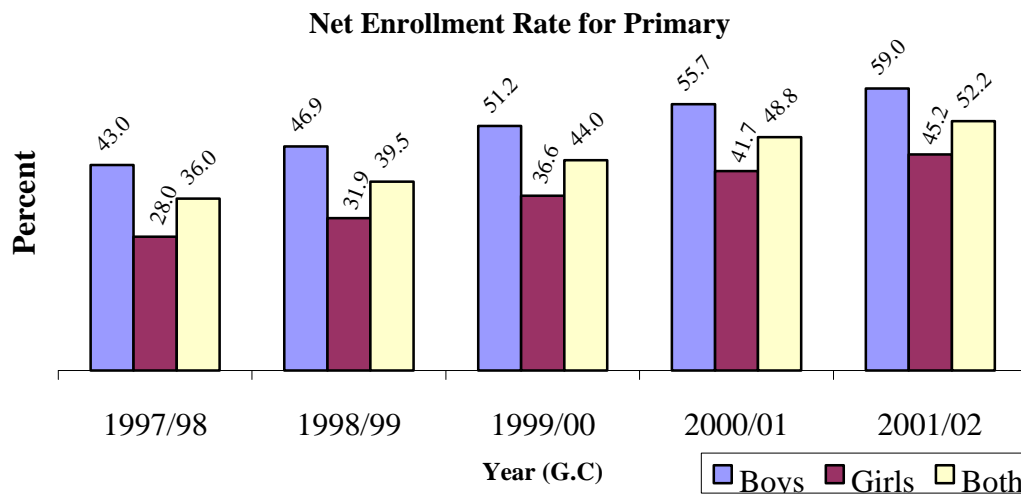

Primary Enrollment – Average Annual Growth Rate

The average annual growth rate of enrollment helps to understand how coverage is progressing every year in each region and at national level. It estimates the annual rate of increase in enrollment. Compounded rate of growth is used to estimate the growth rate in enrollment in the last five years.

The graph below shows the average annual growth rate of enrollment in each region and at national level. In the years 1990-1994 E.C., the highest annual growth rate is recorded in Afar Region (20.1%), and lowest in Gambella (6.3%). At national level the average annual growth rate for the last five years is 12.5%. The highest increase in Afar is due to a smaller base that it started with.

Primary (1-8) Enrollment-Average Annual Growth rate (%)

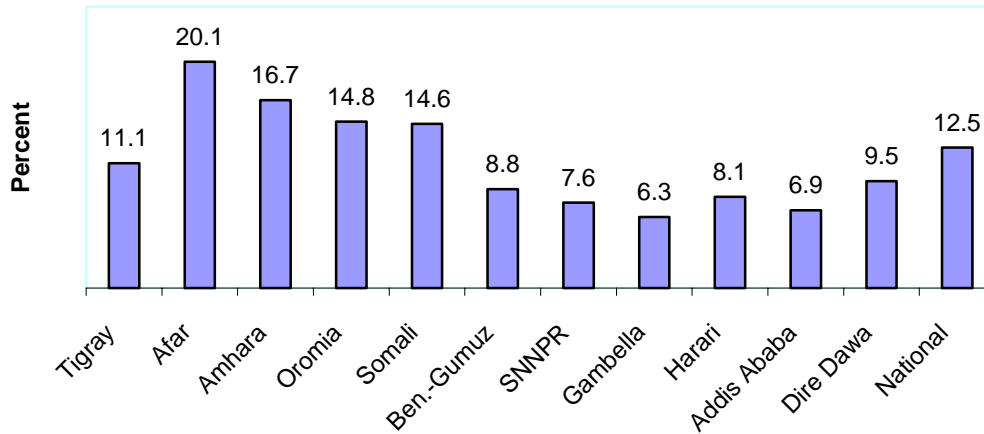

Enrollment in Secondary Schools

In 1994 E.C., 512,327 students were enrolled in secondary schools (9-10), which is higher by 23.5% compared to the previous year. Out of the total enrollment, 201,205 (39.3%) were girls. The evening program contributed 1.6% (44,181) to the total enrollment at this level. Enrollment at this level has been increasing annually at an average growth rate of 13.6% since 1990 E.C. Compared to the previous year, the 1994 E.C. figure for secondary schools has increased both in terms of enrollment and GER.

In 1994 E.C. the GER for girls and boys were 13.7% and 20.4% respectively. As a result the total GER for secondary schools was raised to 17.1 %, which is higher by 3.0 percentage points compared to 1993 E.C.

Per the new Education and Training Policy the pre tertiary program started in 1994. The numbers of students enrolled in grade 11 (preparatory Grades) were 37,001 and Out of the total enrollment 12,495 (33.8%) were girls.

More over, there were students in grade 12 that were studying in the old (phasing out) curriculum and their number was 215,313.

Technical and Vocational Education and Training (TVET)

Recognizing the importance of developing sufficient supply of skilled and productive human power for the economic development, the Education and Training Policy and

the Education Sector Strategy give high priority for the development of technical and vocational education and training program in the country.

Accordingly in 1994 E.C (2001/02) there are 123 government and 18 non-government TVET schools in the country enrolling a total of 38,176 students. Government-run TVETs enrolled 36,462 students while 1714 students were enrolled in non-government institutions. The enrollments both in Government and Non-Government schools do not include students in the evening program and the figures refer only to regular students.

There are also 28 government TVET centers enrolling a total of 12,494 students, which are run by the Ministry of Agriculture.

Higher Education

Enrollment: Total enrollment in the higher education institutions in 1994 E.C. is recorded to be 101,829 in all programmes- Regular, Evening and Kiremt. This shows an increase of 16.5% in access compared to the year 1993 E.C. Out of this non-Government institutions have 19,091 students, which account for 18.75% of the total; and this share is higher by 1.37 percentage point compared to the previous year. All the students reported under the non-government institutions are enrolled for diploma courses. The share of non-government institutions out of the total diploma students stands at 29.0%. However, the figure does not capture the data from few non-government institutions accredited by MoE.

Enrollment in Higher Education Institutions

Program	Enrollment						%Program
	Government		Non-Government		Government and Non-Government		
	BS	F	BS	F	BS	F	
Diploma	46835	11164	19091	10146	65926	21310	64.74
Undergraduate Degree	34556	5489			34556	5489	33.94
Postgraduate Degree	1347	99			1347	99	1.32
Total	82738	16752	19091	10146	101829	26898	

Note: This figure does not also include teacher trainees who are attending diploma programs through distance education, which are about 21,400.

The table above clearly shows that the majority of the students (64.74%) are enrolled in diploma programs followed by the undergraduate degree program (33.94%). Enrollment in postgraduate program accounts only for (1.32%).

In all programs, there were 26,898 (26.4%) female students. The number of female students has not only increased in absolute terms, but its share was also raised from 21.4% in 1993E.C. to 26.4% in 1994 E.C.

Enrollment and number of graduates in regular under graduate degree program have decreased in 1994 E.C. since some of the departments of Addis Ababa University have suspended their students in the first semester.

In general the statistics show that access to higher education is improving through time. This is due to the opening of new Government and Non-Government higher education institutions and the unprecedented expansion within the existing ones. However, the share of female students in higher education institutions is still the lowest compared to the other levels. The data also confirm that the role of non-Government institutions is significant

Graduates: The total number of graduates from all programs was 18,375; of which 4,374 (23.8%) were females. From the Government institutions 14095 students have graduated; of which 2487 (17.6%) were females. From Non-Government institutions 4,280 students have graduated; of which 1,887 (44.1%) were females. The share of Non-Government institutions in terms of graduates is 23.3%.

Equity

Gender Disparity at Primary level: The direction of gender disparity in primary enrollment can be indicated using the Gender Parity Index (GPI), which is the ratio of female to male enrolment rates. In a situation of perfect equality between boys and girls, the lowest value of GPI is 1, and 0 with highest disparity.

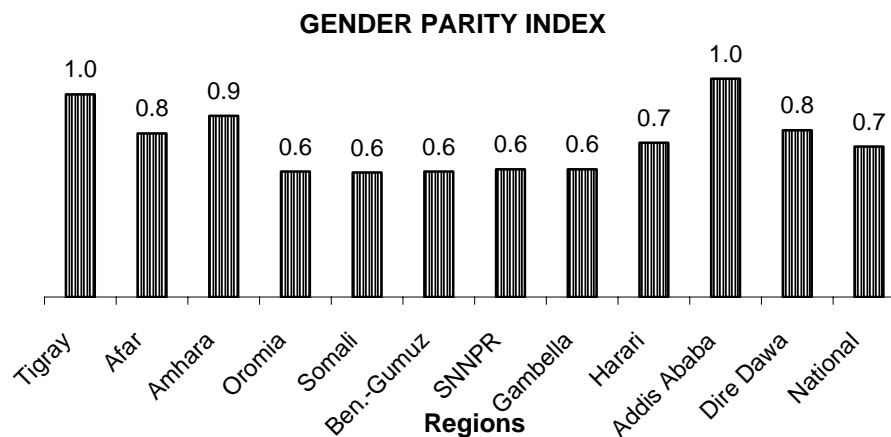

The above graph illustrates the GPI at regional and national level. It can clearly be observed that in 1994 E.C. (2001/02), the GPI is 0.7 at national level indicating that girls' participation is lower than boys. This is true for all regions except Addis Ababa (a little above 1) and Tigray (close to 1). Somali, Oromia, Gambella, Benishangul-Gumuz, and SNNPR, which have a GPI of 0.6, have largest disparity between boys and girls.

Urban-Rural Disparity:

A comparison of rural and urban enrollment indicates that 67.93% of primary enrollment (both regular and evening) accounted from rural areas. However, when we see enrollment in senior secondary schools (9-10), rural enrollment accounts only for 2.57%.

The proportion of girls enrolled in urban and rural areas can be observed from the following table.

Urban / Rural Enrollment by level

Level	Urban Enrollment		Rural Enrollment	
	%Female	%Male	%Female	%Male
Primary (1-8)	45.4	54.6	38.8	61.2
Secondary (9-10)	39.4	60.6	35.5	64.5

Among those enrolled, the proportion of girls is lower in rural and primary level than the proportion of boys in urban and secondary levels. This indicates the need to exert a concerted effort to make females, who account for half of the population, beneficiary from the education system.

Regional Disparity

The figure below shows a comparison of primary GER taking Addis Ababa as a point of reference, assuming it has better educational facilities. Only Harari Region showed a difference of less than 25 percentage points in GER compared to Addis Ababa, The rest have much difference in primary GER showing that the regional disparity in coverage is still high.

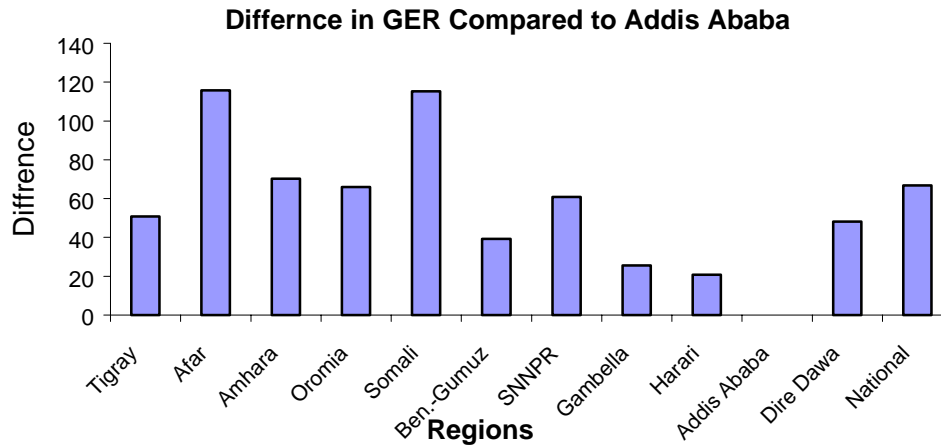

Quality

Percentage of certified primary school teachers

According to the national standards, the first cycle (1-4) primary education requires teachers with minimum qualification of Teacher Training Institutes (TTI) certificate. Similarly Teacher Training Collages' diploma is required for the second cycle (5-8) teachers.

The graphs below show the proportions of certified primary school teachers at regional and national level for the two cycles of primary education separately. At national level, in 1994 E.C 95.6 % of first cycle primary school (grades 1-4) teachers are certified, while in the second cycle (grades 5-8) only 25.5% are certified.

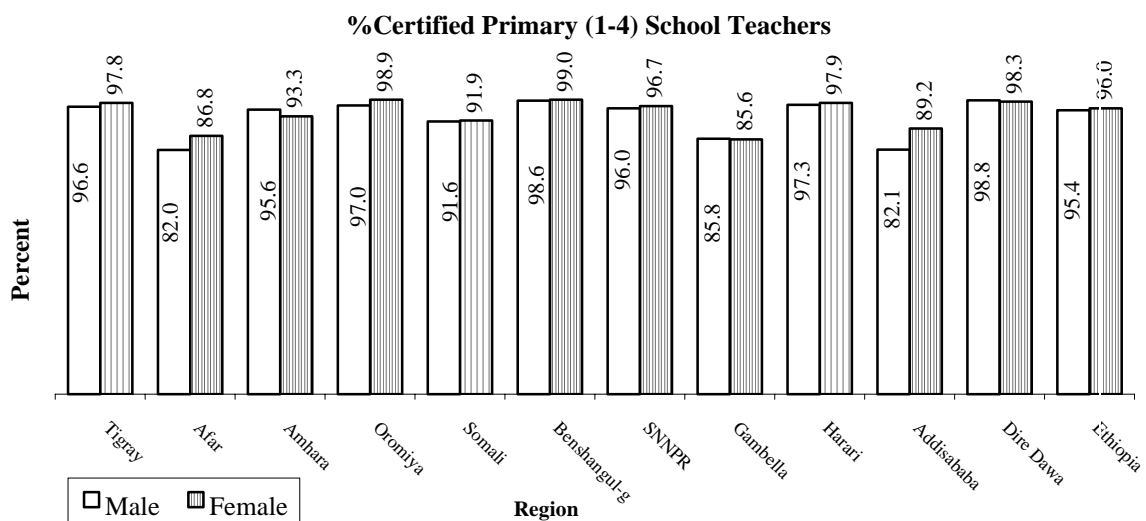

Currently about 21,400 primary school teachers are enrolled in diploma program through distance education to upgrade their level of qualification from certificate to diploma level.

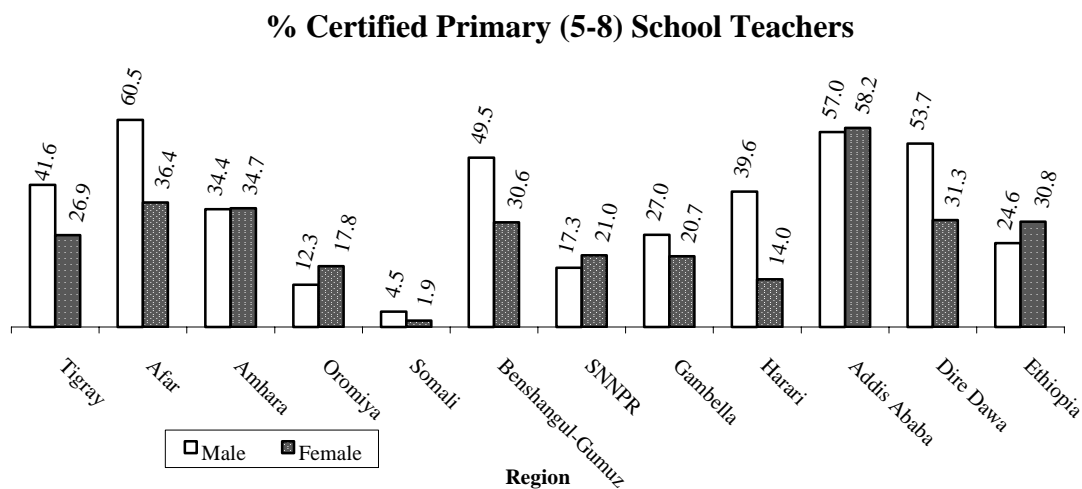

Comparatively, the first cycle primary education has higher percentage of certified teachers for the level than the second cycle. The teachers currently studying through distance education are expected to improve the situation in the second cycle primary after completion of their study.

Percentage of secondary school teachers who are certified: According to the Ethiopian education standard the minimum qualification required to teach at secondary level is at least first degree.

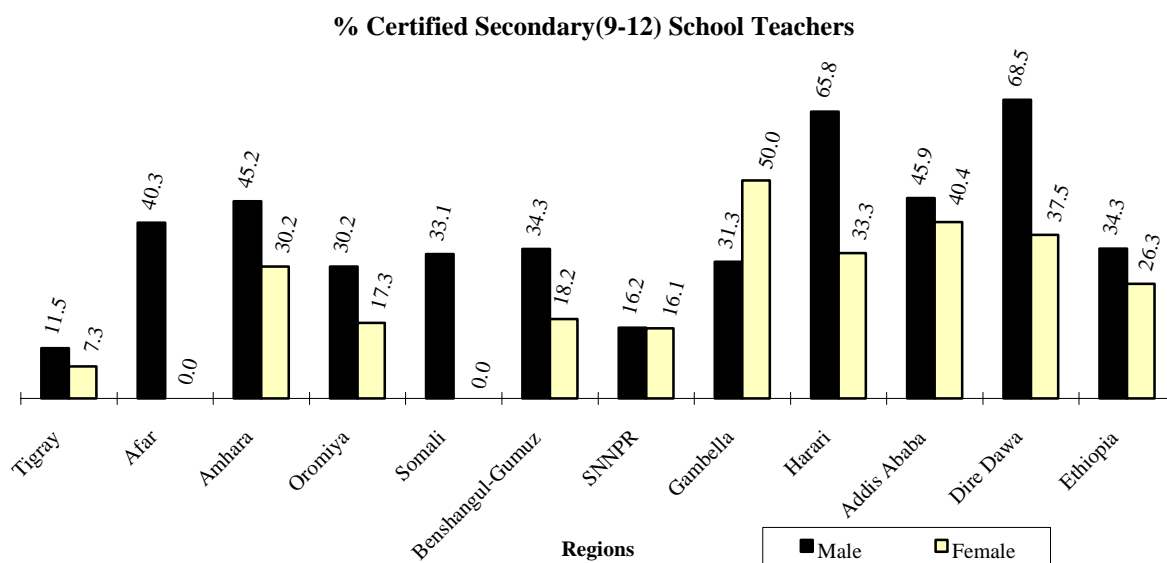

The proportion of qualified secondary school teachers in 1994 E.C. varies from region to region and ranges from the highest in Dire Dawa (67.1%) to the lowest in Tigray (11.1%).

At national level only 33.7% of the teachers who have been serving in secondary schools in 1994 E.C. are qualified for the level. To improve this situation, currently 5,716 teachers, who have diploma and teach in secondary schools, are enrolled in kiremt undergraduate degree programs.

Efficiency

Pupil-Teacher Ratio (PTR): Pupil teacher ratio is one of the common education indicators on efficiency and quality. The lower the PTR the higher the opportunity of contact between teacher and pupils to check homework and class work as well as give support to students individually. On the other hand, very low PTR may indicate inefficient or under utilization of teachers. Low or high PTR alone may not be enough to explain the quality of education because quality of education also depends (in addition to the PTR) on the mode of delivery, commitment and qualification of the teacher, availability of educational inputs, etc.

Moreover, this indicator is very useful when there is a standard set in the context of the country. In Ethiopia the pupil/teacher ratio is 50 and 40 for the primary and secondary respectively.

Primary PTR in the last five years shows an increasing trend at national level, from 47 in 1990 E.C. (1997/98) to 63 in 1994 E.C. (2001/02). This is higher by 3 compared to 1993 E.C. and this shows the need to stop its upward movement and bring it down to the standard.

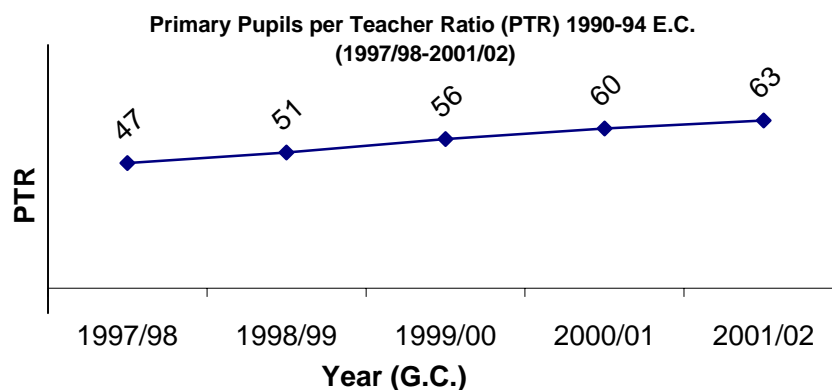

The PTR for regular secondary schools has increased from 46 in 1993E.C. to 49 in 1994 E.C. (2001/02).

Usually the national level figures reflect the general direction, and may not show clear pictures as they mask the variations at lower levels. PTR at school level shows a better picture of the situation of the actual teaching learning process.

Pupil-Section Ratio (PSR): This ratio is one of the efficiency indicators, a lower ratio in comparison to the national standard means under utilization of resources. The target set for pupil (student)/section ratio for both levels (primary and secondary) is 60. However, in 1994 E.C. the pupil (student)/section ratio were 73 and 80 for primary and secondary schools respectively.

Efficiency Rates: These rates help us to understand how the education system works in terms of the use of available resource and time. A student has three paths in a particular academic year, i.e. Promotion, repetition or dropout. These rates are commonly used to measure the efficiency of the education system in producing graduates of a particular education cycle or level. Repeating a grade means utilizing more resource than allocated to a student; and leaving a school (dropout) before completing a particular cycle or level of education is also wastage of resources. In both cases, the meager resource allocated for education and time will be wasted or under utilized. Therefore, Repetition and Dropout rates are indicators of the level of efficiency of the education system.

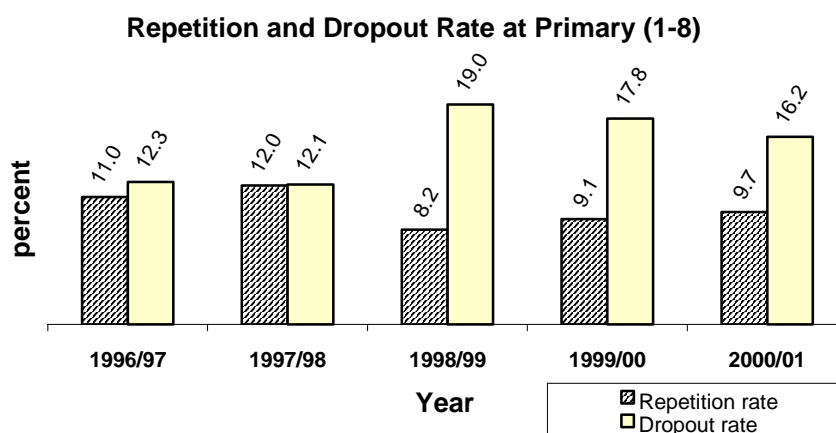

We can observe from the above graph that compared to the previous years, the dropout rate has decreased, while the repetition rate has slightly increased in 1994E.C. The figure also shows that 74.1% of the previous year students have promoted to the next grade while the remaining 16.2% have dropped out and 9.7% have repeated grades.

It is important to note that the data on dropout and repetition lags by one year, i.e. the 2001/02 publication reports those who were not promoted to the next grade at the end of 2000/01 academic year.

Repetition Rates by Grade: This indicator measures the proportion of students who have remained in the same grade over one year, and have used more resource for that grade.

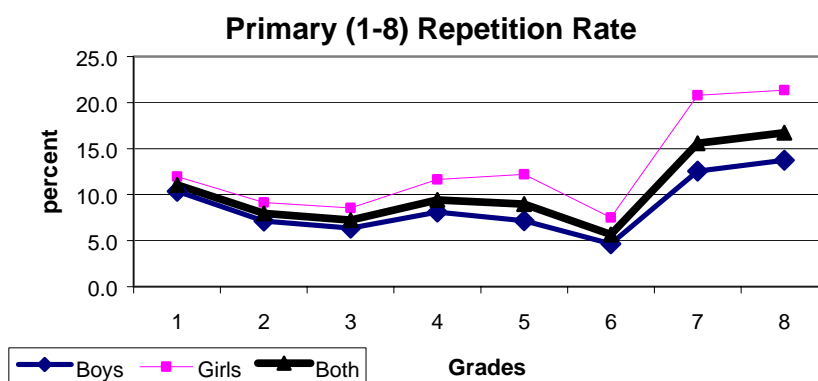

The resources are in the form of teacher salary, school materials, facilities etc. This reduces the internal efficiency of the system. The policy allows automatic promotion for the first three grades of primary. But in practice repeaters in those grades are still reported.

The above graph shows repetition rates by grade at primary level and the following facts are observed from the graph.

- Girl's repetition rate in all grades is higher than boys. The repetition rate for girls, boys and both-combined show similar pattern. From all grades the lowest repetition rates are at grade six and the highest at grade 8.
- The repetition rate for girls at grade 1 is 11.9%, and this is a little higher compared to the previous year, which was 11.6%.
- The repetition rate for both sexes at grade one is 11.1%.

Dropout Rates by Grade: The proportion of pupils who leave the school varies from grade to grade. In most cases this figure is higher for grade one. At national level, 27.5% of pupils enrolled in grade 1, in 1993 E.C. have left school before reaching grade two in 1994 E.C. The figure below shows that dropout rate is highest at grade 1 and lowest at grade 6. The average duration of study for dropouts (who do not complete their primary schooling), i.e. the average number of years they stayed in the education system before they dropout is 3.3 for boys, 3.4 for girls and 3.3 for both. Even though it is not significant, the figure tells us that girls stay more in the primary education than boys do.

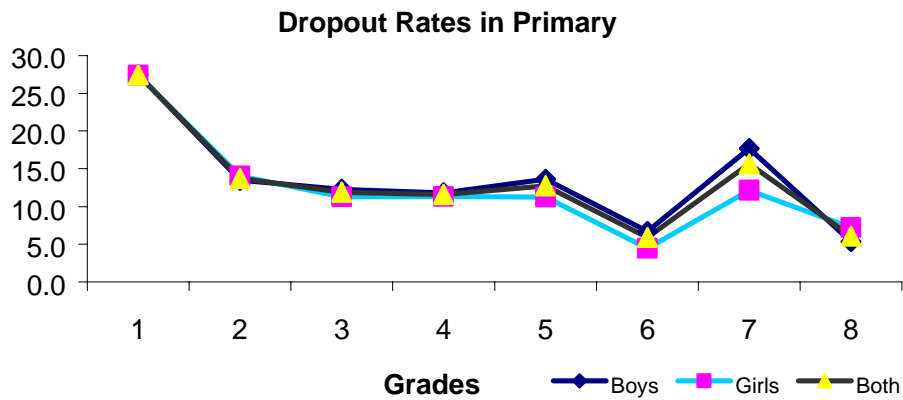

The figure above illustrates that in all grades except grade 2 and 8, the rate of dropout is lower for girls than for boys.

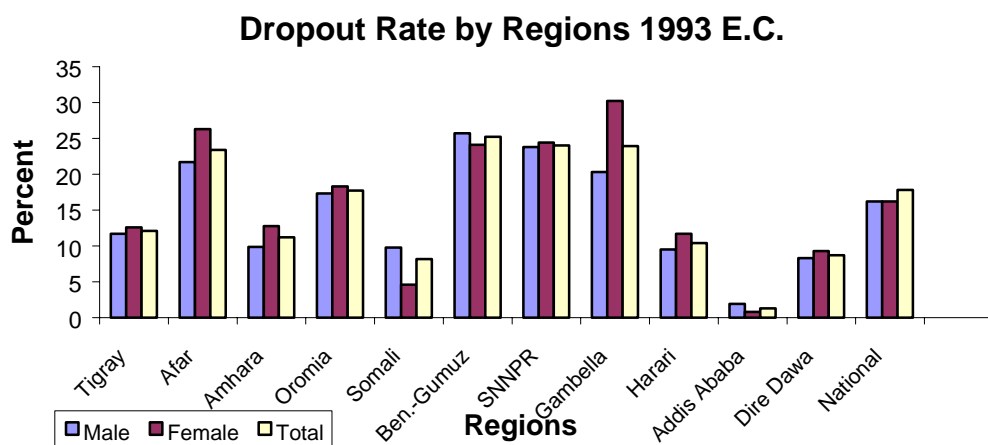

The above graph shows the dropout rate for primary in each region during the last academic year (1993 E.C.). Addis Ababa had the lowest dropout rates, while

Benishangul-Gumuz had the highest dropouts rate, 25.2%. Similarly, Gambella had the highest dropout rate for girls, 30.2%. The reasons for dropouts vary from region to region.

Therefore, a concerted effort of all stakeholders is required in order to decrease the dropout rates and to enable pupils complete at least primary education.

Survival Rate to Grade 5: Survival rate at this grade is used to estimate the percentage of students who will complete the first cycle of primary education, since the completion of at least 4 years of schooling is commonly considered as a pre-requisite for a sustainable level of literacy. Survival rate approaching 100% indicates a high level of retention and low incidence of dropout. The reliability of this indicator depends on the consistency of data on enrolment and repeaters both in terms of coverage over time and across grades as it is calculated based on these figures. We use cohort analysis to calculate this rate, by assuming a group of pupils who are enrolled in grade1 at the same time and no other students joining the group or transfer with in 10 years, as completing primary education requires minimum 8 years and maximum 10 years.

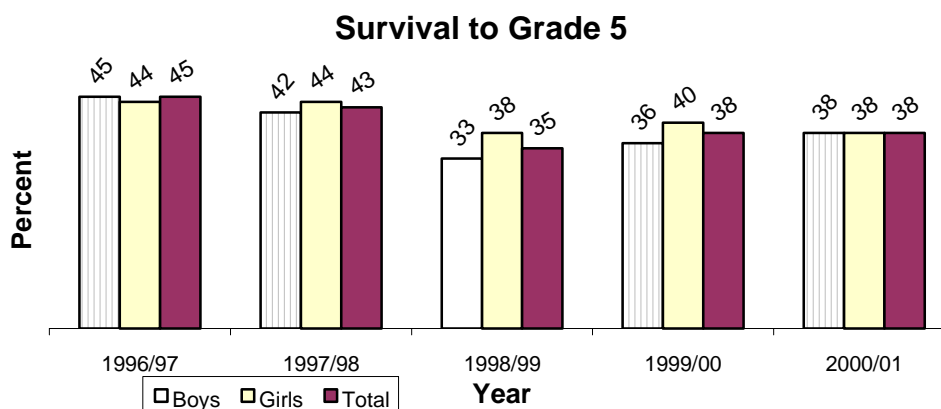

The cohort flow model constructed for the last five years, as indicated in the above graph, showed that survival rate to grade 5 is decreasing from year to year until 1998/99. In other words, the chance of pupils to continue in the second cycle of primary is decreasing through time until 1998/99, but in 1999/00 it showed improvement. The survival rate to grade 5 for girls is better compared to boys from 1997/98 to 1999/00 and same as that of boys in 2000/01.

Coefficient of Efficiency (CE): This efficiency indicator is calculated based on the result of the cohort analysis. It mainly depends on graduates (out puts) and the time required to produce the graduates. It is based on the definition that one school year spent in a grade by a pupil is counted as one pupil-year. The coefficient of efficiency is the ratio of the ideal (optimal) number of pupil-years required (with no repetition nor dropout) to produce a number of graduates from a given school cohort in primary education expressed as a percentage of the actual number of pupil-years spent to produce the same number of graduates. It is the reciprocal of the input-output ratio. It is used as an alternative indicator of internal efficiency. It measures the impact of dropout and repetition combined in relation to graduates from the primary level. The maximum value of CE is 100, which indicates highly efficient system and the lower CE is the lower the efficiency of the education system.

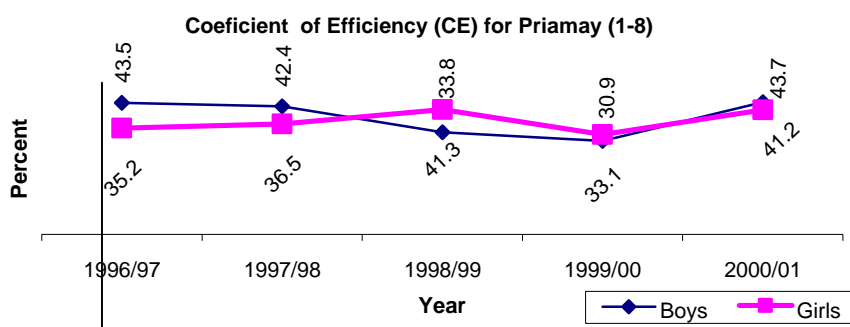

The estimated Coefficient of Efficiency for 1993 E.C. shows that it was only 42.8%. This figure was 41.2% for girls and 43.7% for boys. It is better for boys compared to girls. As it could be seen from the graph above, the efficiency of the system of primary education for girls was improving through time until 1998/99 and declined in 1999/00 and then increased in 2000/01. On the other hand the CE for boys shows a tendency of decreasing until 1999/00 and then started to increase in 2000/01. The trend warns all stakeholders (i.e., educators, planners, decision makers etc.) that there is a need to investigate the causes for low CE and to take corrective measures immediately.

School Facilities

School facilities have impact on accesses, quality, efficiency and equity. The school facilities are tools to attract students in general and girls in particular.

The degree of shift system and availability of water, latrines, clinic, libraries, laboratories and pedagogical centers in schools in 1994 E.C. are presented in the following table. Significant numbers of schools haven't reported on the availability of the mentioned facilities. This table shows only for those schools that have reported on facilities and shift system.

School Facilities

Level	Shift System		Water		Latrines		Clinic		Library		Pedagogical Center		No. of Laboratories
	No	yes	Yes	No	Yes	No	Yes	No	Yes	No	Yes	No	
1-4	3635	1182	1890	3028	3183	1736	62	4852	889	4030	2923	1996	-
1-8	3139	3860	3499	3515	5698	1318	199	6810	3025	3990	6102	913	-
9-10	25	18	27	15	32	11		43	35	8	33	10	53
9-12	52	244	249	48	269	28	40	255	280	16	251	47	497
1-12	57	50	80	29	100	9	20	89	98	11	90	19	119
Total	6908	5354	5745	6635	9282	3102	321	12049	4327	8055	9399	2985	669

- **Shift system:** In 1994 E.C. 42.13% of primary and 68.57% of secondary schools have reported to use shift systems (primary schools in 1-12 are also considered).
- **Water:** About 45.8% (5745) of all schools have reported to have water facilities.
- **Latrines:** Only 74.00% (9282) of all schools reported to have latrines.
- **Clinics:** Of all schools, only 2.6% (321) of them reported to have clinics serving students.
- **Pedagogical Center:** all levels combined, 74.9% of the schools reported to have pedagogical centers.
- **Libraries:** of all schools with grades 9 and above, 90.8% (413) have library facilities.
- **Laboratories:** The availability of 669 laboratory facilities in the senior secondary schools is reported. This figure is higher compared to the number of secondary schools (455); this is because some schools have two or more laboratories.

Although significant proportions of the schools have not reported at all about facilities, it can be concluded from the figures that the facilities available in the schools (regardless of their quality) are not sufficient to conduct the teaching learning process.

Education Budget and Expenditure:

The Government of the Federal Democratic Republic of Ethiopia is committed to the provision of better education that can address the needs of the society. This is witnessed by the budget allocation to the sector, which is growing at faster rate from year to year.

The education statistics shows that the education budget has increased through time. It was Birr 1.5 billion in 1989 E.C. (1996/97) and increased to about Birr 2.5 billion in 1993 E.C. (200/01), which is a remarkable increase within five years. In the same year the share of primary education out of the total education budget amounts to 50.12%.

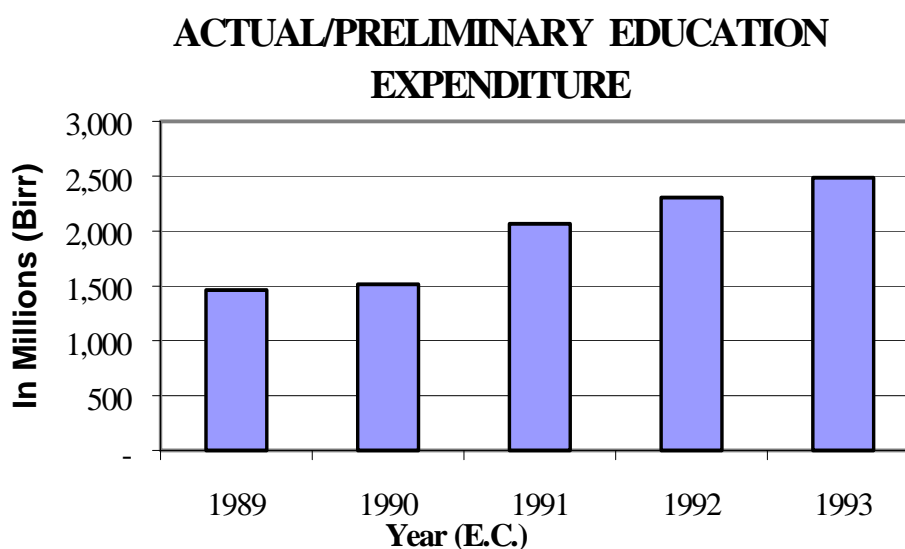

Source: MoF

The above graph clearly shows the trend of budget allocation for education in the last five years. The data for 1989-91 E.C is preliminary actual expenditure while for 1992-93 E.C. figure refers to the budget. Capital budget for the year 1994 E.C is not available. However, the recurrent budget is 1.8 billion; and has a share of 16.1% out of the total national recurrent budget (11.4 billion).

The Education Sector Development Program (ESDP)

The first Education Sector Development Program is the first five-year program of the twenty years long-term plan to achieve Universal Primary Education by the year 2015.

Over the five years period (1997/98-2001/2002), the ESDP I is designed to focus on Access, Quality, Efficiency and Equity in education. It also gives priority for the expansion of primary education with special attention to girls, rural and underserved areas.

More specifically, ESDP I is based on the following objectives.

- Expand access by raising primary enrolment from 3.1 to 7 million and achieve an average gross enrolment ratio of 50% for primary education;
- Improve the quality of education by extending the new curriculum to all levels of the system, increasing the number of certified primary teachers from 85% to 95% and lower the textbook ratio at the primary level from 5:1 to 1:1 in core subjects;
- Increase efficiency by more effective utilization of teachers with an average 50:1 (pupil/teacher ratio) and raising the coefficient of efficiency from 49.6% to 80%, the system coefficient reflecting a reduction of the number of dropouts and repeaters’;
- Improving equity by achieving a gross enrolment rate for primary education at least 25% in underserved regions; raise the female participation share in primary school from 36.8% to 45%;
- Increase financing for education by raising public expenditure on education to 4.6% of GDP; achieve a target of 5% new school construction owned by non-government institutions, and introduce cost sharing at the tertiary level.

Comparison with *Key Performance indicators of the ESDP*

S. No.	<i>Suggested Indicators</i>	<i>Base-Year 1995/96</i>	<i>Status of 2001/02</i>	<i>2001/02 Target</i>
	Budgetary and Expenditure Indicators			
1	<ul style="list-style-type: none"> • Education's Share of the total budget (current FY) • Primary education share of the total education budget 	13.7%		19.0%
		46.2%		65%
	Access Indicators			
2	<ul style="list-style-type: none"> • Total number of primary schools • Total primary (grade 1-8) enrollments ('000) 	9,670	12,087	12,595
		3,788	8,144	7,000
	Quality Indicators			
3	<ul style="list-style-type: none"> • Share of lower primary (grades 1-4) teachers who are qualified • Total number of upper primary (grades 5-8) teachers • Number of qualified upper primary teachers • Total number of Secondary teachers • Number of qualified Secondary teachers • Number of core primary textbooks in school • Grade 8 examination pass rate • Grade 4 sample assessment of learning achievements 	85%	95.6%	95%
		27,381	47,718	36,777
		5,729	12,186	20,000
		12,143	14,091	17,463
		4,910	4,751	10,760
		2,273,000		51,000,000
		61.7%	n.y.a.	80.0%
		n.y.a.	n.y.a.	n.y.a.
	Efficiency indicators			
4	<ul style="list-style-type: none"> • Primary school student: section ratio • Secondary school student: section ratio • Grade 1 dropout rate • Total primary school dropout • Average grade 4 to 8 repetition rate* • Average grade 4 to 8 repetition rate for girls* • Coefficient of primary school efficiency 	52	73	50
		63	80	50
		28.5%	27.5%	14.2%
		8.4%	16.2%	4.2%
		12.8%	10.5%	6.4%
		16.2%	13.6	8.1%
		60%	32.8%	80.0%
	Equity Indicators			
5	<ul style="list-style-type: none"> • Gross primary enrollment ratio in the two most under-served areas • Share of girls in primary school enrollment (grades 1-6) 	16.2%	13.0%	25.0%
		38.0%	41.4%	45.0%

Note: under *Status of 2001/02* column data related to repetition and dropout indicate for the end of 1993 E.C.

* *Calculated using geometric mean.*

n.y.a.: not yet available

As over 85% of these indicators are planned to be verified by the educational statistics that is produced by EMIS, the available information for 1994 E.C. (2001/02) is indicated under "*Status of 2001/02*" column of the table. It can easily be observed how far the ESDP I has gone to reach at its targets.

General Education

Level	1990 E.C. /1997-98/	1994 E.C. /2001-02/	AAGR
1. Enrollment			
1. Primary education			
1.1 Grade 1-6	4607733	7213023	11.9
1.2 Grade 1-8	5090670	8144337	12.5
2. Secondary education (9-10)	307887	512327	13.6
3. Secondary Education (Grade 12)		215313	
4. Pre tertiary (Grade 11)		37001	
2. Teachers			
1. Primary education (1-8)	109237	126882	3.8
2. Senior Secondary education (9-12)	12329	14091	3.4
3. Schools			
1. Primary education(1-8)	10752	12089	3.0
2. Senior secondary education(9-12)	382	455	4.5
4. Gross Enrollment Ratios			
1. Primary education			
1.1 Grade 1-6	49.2%	71.5%	
1.2 Grade 1-8	41.8%	61.6%	
2. Secondary education (9-10)	11.3%	17.1%	
5. Student Section Ratio			
1. Primary education	60	73	
2. Senior secondary education (9-12)	68	80	
6. Pupil/Teacher ratio			
1. Primary education	47	63	
2. Senior secondary education (9-12)	38	49	
7. Percentage of female students			
1. Primary education	36.7	40.9	
2. Senior secondary education (9-12)	40.9	39.3	
8. Percentage of female teachers			
1. Primary education	27.2	31.1	
2. Senior secondary education(9-12)	8.6	7.8	

TVET

	1990 E.C. /1997-98/	1994 E.C. /2001-02/	AAGR
1. Enrollment	2811	38176	92.0
2. Teachers	358	2214	57.7
3. Schools	15	141	75.1
4. Percentage of female students	21.2	47.0	

Higher Education

	1990 E.C. /1997-98/	1994 E.C. /2001-02/	AAGR
1. Enrollment	45554	101829	22.3
2. Graduates	7993	18375	23.1
3. Teachers	1961	3313	14.0

AAGR: Average Annual Growth Rate

Total Population, School Age Population, Enrollment and Gross Enrollment Ratios by Region and Sex

(Regular & Evening)

Primary (Grade 1-4): 1994 E.C. (2001/02)

Region	Total Population			School Age Population (7-10)			Enrollment			Gross Enrollment Ratio		
	Total	Male	Female	Both	Boys	Girls	Both	Boys	Girls	Both	Boys	Girls
Tigray	3,797,000	1,868,000	1,929,000	407,815	207,406	200,410	412,084	207,748	204,336	101.0	100.2	102.0
Afar	1,243,000	696,000	547,000	123,337	69,567	53,770	22,884	14,661	8,223	18.6	21.1	15.3
Amhara	16,748,000	8,380,000	8,368,000	1,765,618	889,415	876,203	1,446,217	760,324	685,893	81.9	85.5	78.3
Oromiya	23,023,000	11,492,000	11,531,000	2,482,681	1,250,863	1,231,818	2,174,852	1,323,548	851,304	87.6	105.8	69.1
Somali	3,797,000	2,052,000	1,745,000	411,279	222,610	188,669	86,157	57,348	28,809	20.9	25.8	15.3
Benshangul-Gumuz	551,000	278,000	273,000	59,617	30,532	29,085	73,562	45,093	28,469	123.4	147.7	97.9
SNNPR	12,903,000	6,412,000	6,491,000	1,379,891	694,729	685,162	1,289,161	779,378	509,783	93.4	112.2	74.4
Gambella	216,891	110,487	106,404	20,381	10,551	9,830	28,698	17,655	11,043	140.8	167.3	112.3
Harari	165,814	83,910	81,904	12,972	6,693	6,279	17,010	9,668	7,342	131.1	144.4	116.9
Addis Ababa	2,570,000	1,237,000	1,333,000	153,945	76,917	77,028	238,121	111,948	126,173	154.7	145.5	163.8
Dire Dawa	330,062	165,775	164,287	26,406	13,602	12,804	25,071	14,180	10,891	94.9	104.2	85.1
Total	65,344,767	32,775,172	32,569,595	6,843,942	3,472,885	3,371,058	5,813,817	3,341,551	2,472,266	84.9	96.2	73.3

Primary (Grade 5-8): 1994 E.C. (2001/02)

Region	Total Population			School Age Population (11-14)			Enrollment			Gross Enrollment Ratio		
	Total	Male	Female	Both	Boys	Girls	Both	Boys	Girls	Both	Boys	Girls
Tigray	3,797,000	1,868,000	1,929,000	373,493	189,452	184,041	194,118	106,160	87,958	52.0	56.0	47.8
Afar	1,243,000	696,000	547,000	121,239	69,946	51,293	7,851	4,738	3,113	6.5	6.8	6.1
Amhara	16,748,000	8,380,000	8,368,000	1,615,015	815,647	799,368	517,884	303,891	213,993	32.1	37.3	26.8
Oromiya	23,023,000	11,492,000	11,531,000	2,276,545	1,150,045	1,126,500	795,114	550,766	244,348	34.9	47.9	21.7
Somali	3,797,000	2,052,000	1,745,000	401,333	221,847	179,486	20,415	14,220	6,195	5.1	6.4	3.5
Benshangul-Gumuz	551,000	278,000	273,000	54,946	28,019	26,927	28,462	19,893	8,569	51.8	71.0	31.8
SNNPR	12,903,000	6,412,000	6,491,000	1,264,025	637,271	626,754	495,249	337,502	157,747	39.2	53.0	25.2
Gambella	216,891	110,487	106,404	20,059	10,317	9,742	12,841	8,823	4,018	64.0	85.5	41.2
Harari	165,814	83,910	81,904	13,517	6,892	6,625	11,462	7,128	4,334	84.8	103.4	65.4
Addis Ababa	2,570,000	1,237,000	1,333,000	210,028	98,413	111,615	229,043	108,967	120,076	109.1	110.7	107.6
Dire Dawa	330,062	165,775	164,287	27,410	13,705	13,705	18,081	10,216	7,865	66.0	74.5	57.4
Total	65,344,767	32,775,172	32,569,595	6,377,610	3,241,554	3,136,056	2,330,520	1,472,304	858,216	36.5	45.4	27.4

Primary (Grade 1-6): 1994 E.C. (2001/2002)

Region	Total Population			School Age Population (7-12)			Enrollment			Gross Enrollment Ratio		
	Total	Male	Female	Both	Boys	Girls	Both	Boys	Girls	Both	Boys	Girls
Tigray	3,797,000	1,868,000	1,929,000	599,278	304,622	294,656	521,791	267,209	254,582	87.1	87.7	86.4
Afar	1,243,000	696,000	547,000	184,305	104,516	79,789	27,081	17,143	9,938	14.7	16.4	12.5
Amhara	16,748,000	8,380,000	8,368,000	2,593,391	1,307,166	1,286,225	1,774,388	952,222	822,166	68.4	72.8	63.9
Oromiya	23,023,000	11,492,000	11,531,000	3,648,426	1,839,308	1,809,118	2,672,499	1,668,941	1,003,558	73.3	90.7	55.5
Somali	3,797,000	2,052,000	1,745,000	613,637	333,809	279,828	99,119	66,197	32,922	16.2	19.8	11.8
Benshangul-Gumuz	551,000	278,000	273,000	87,784	44,912	42,872	91,498	57,446	34,052	104.2	127.9	79.4
SNNPR	12,903,000	6,412,000	6,491,000	2,027,425	1,021,020	1,006,405	1,582,773	977,957	604,816	78.1	95.8	60.1
Gambella	216,891	110,487	106,404	30,446	15,737	14,709	36,954	23,001	13,953	121.4	146.2	94.9
Harari	165,814	83,910	81,904	19,569	10,080	9,489	23,070	13,494	9,576	117.9	133.9	100.9
Addis Ababa	2,570,000	1,237,000	1,333,000	250,414	122,947	127,467	349,308	165,579	183,729	139.5	134.7	144.1
Dire Dawa	330,062	165,775	164,287	39,834	20,415	19,419	34,542	19,614	14,928	86.7	96.1	76.9
Total	65,344,767	32,775,172	32,569,595	10,094,509	5,124,532	4,969,977	7,213,023	4,228,803	2,984,220	71.5	82.5	60.0

Source of Population Data: 1994 E.C. (2001/02) Projected Central Statistical Authority (CSA)

Total Population, School Age Population, Enrollment and Gross Enrollment Ratios by Region and Sex

(Regular & Evening)

Primary (Grade 1-8): 1994 E.C. (2001/02)

Region	Total Population			School Age Population (7-14)			Enrollment			Gross Enrollment Ratio			
	Total	Male	Female	Both	Boys	Girls	Both	Boys	Girls	Both	Boys	Girls	
Tigray	3,797,000	1,868,000	1,929,000	781,309	396,858	384,451	606,202	313,908	292,294	77.6	79.1	76.0	
Afar	1,243,000	696,000	547,000	244,575	139,512	105,063	30,735	19,399	11,336	12.6	13.9	10.8	
Amhara	16,748,000	8,380,000	8,368,000	3,380,633	1,705,062	1,675,571	1,964,101	1,064,215	899,886	58.1	62.4	53.7	
Oromiya	23,023,000	11,492,000	11,531,000	4,759,225	2,400,908	2,358,317	2,969,966	1,874,314	1,095,652	62.4	78.1	46.5	
Somali	3,797,000	2,052,000	1,745,000	812,612	444,457	368,155	106,572	71,568	35,004	13.1	16.1	9.5	
Benshangul-Gumuz	551,000	278,000	273,000	114,563	58,551	56,012	102,024	64,986	37,038	89.1	111.0	66.1	
SNNPR	12,903,000	6,412,000	6,491,000	2,643,916	1,332,000	1,311,916	1,784,410	1,116,880	667,530	67.5	83.8	50.9	
Gambella	216,891	110,487	106,404	40,438	20,867	19,571	41,539	26,478	15,061	102.7	126.9	77.0	
Harari	165,814	83,910	81,904	26,487	13,584	12,903	28,472	16,796	11,676	107.5	123.6	90.5	
Addis Ababa	2,570,000	1,237,000	1,333,000	363,973	175,330	188,643	467,164	220,915	246,249	128.4	126.0	130.5	
Dire Dawa	330,062	165,775	164,287	53,816	27,307	26,509	43,152	24,396	18,756	80.2	89.3	70.8	
Total(Regular+Even.)	65,344,767	32,775,172	32,569,595	13,221,547	6,714,436	6,507,111	8,144,337	4,813,855	3,330,482	61.6	71.7	51.2	
							Regular	7,982,760	4,728,450	3,254,310	60.4	70.4	50.0
							Evening	161,577	85,405	76,172	1.2	1.3	1.2

Secondary 1st Cycle (Grade 9-10): 1994 E.C. (2001/02)

Region	Total Population			School Age Population (15-16)			Enrollment			Gross Enrollment Ratio			
	Total	Male	Female	Both	Boys	Girls	Both	Boys	Girls	Both	Boys	Girls	
Tigray	3,797,000	1,868,000	1,929,000	171,626	86,697	84,929	65,690	40,134	25,556	38.3	46.3	30.1	
Afar	1,243,000	696,000	547,000	59,231	34,855	24,376	2,466	1,469	997	4.2	4.2	4.1	
Amhara	16,748,000	8,380,000	8,368,000	743,433	376,313	367,120	89,234	51,766	37,468	12.0	13.8	10.2	
Oromiya	23,023,000	11,492,000	11,531,000	1,051,384	532,418	518,966	166,850	107,564	59,286	15.9	20.2	11.4	
Somali	3,797,000	2,052,000	1,745,000	194,180	109,341	84,839	4,383	3,363	1,020	2.3	3.1	1.2	
Benshangul-Gumuz	551,000	278,000	273,000	25,187	12,792	12,395	4,171	2,912	1,259	16.6	22.8	10.2	
SNNPR	12,903,000	6,412,000	6,491,000	583,059	294,441	288,618	77,090	52,572	24,518	13.2	17.9	8.5	
Gambella	216,891	110,487	106,404	9,904	5,062	4,842	1,652	1,289	363	16.7	25.5	7.5	
Harari	165,814	83,910	81,904	7,362	3,660	3,702	4,389	2,564	1,825	59.6	70.1	49.3	
Addis Ababa	2,570,000	1,237,000	1,333,000	132,014	59,115	72,899	91,498	44,664	46,834	69.3	75.6	64.2	
Dire Dawa	330,062	165,775	164,287	14,751	7,014	7,737	4,904	2,825	2,079	33.2	40.3	26.9	
Total(Regular+Even.)	65,344,767	32,775,172	32,569,595	2,992,131	1,521,708	1,470,423	512,327	311,122	201,205	17.1	20.4	13.7	
							Regular	468,146	289,752	178,394	15.6	19.0	12.1
							Evening	44,181	21,370	22,811	1.6	1.4	1.7

Source of Population Data: 1994 E.C. (2001/02) Projected Central Statistical Authority (CSA)

Gross Enrollment Ratio, gender gap and gender parity index by Level and region 1994 E.C. (2001/02)

Region	Primary (1-8)					Secondary (9-10)				
	Male	Female	Total	G.G.	G.P.I.	Male	Female	Total	G.G.	G.P.I.
Tigray	79.1	76.0	77.6	3.1	1.0	46.3	30.1	38.3	16.2	0.7
Afar	13.9	10.8	12.6	3.1	0.8	4.2	4.1	4.2	0.1	1.0
Amhara	62.4	53.7	58.1	8.7	0.9	13.8	10.2	12.0	3.6	0.7
Oromiya	78.1	46.5	62.4	31.6	0.6	20.2	11.4	15.9	8.8	0.6
Somali	16.1	9.5	13.1	6.6	0.6	3.1	1.2	2.3	1.9	0.4
Benshangul Gumuz	111.0	66.1	89.1	44.9	0.6	22.8	10.2	16.6	12.6	0.4
SNNPR	83.8	50.9	67.5	33.0	0.6	17.9	8.5	13.2	9.4	0.5
Gambella	126.9	77.0	102.7	49.9	0.6	25.5	7.5	16.7	18.0	0.3
Harari	123.6	90.5	107.5	33.2	0.7	70.1	49.3	59.6	20.8	0.7
Addis Ababa	126.0	130.5	128.4	-4.5	1.0	75.6	64.2	69.3	11.3	0.9
Dire Dawa	89.3	70.8	80.2	18.6	0.8	40.3	26.9	33.2	13.4	0.7
Ethiopia	71.7	51.2	61.6	20.5	0.7	20.4	13.7	17.1	6.8	0.7

G.G. = Gender Gap (the difference between the male and female enrolment ratios)

G.P.I. = Gender Parity Index (the ratio between the female and the male enrolment ratios)

Enrollment Ratios 1994 E.C. (2001/02)

(Regular)

Age in Years	Pupils						School Age Population			Age Specific Gross Enrolment Ratio				
	Primary (1-8)			Senior Secondary (9-12)			Male	Female	Total	Boys	Girls	Total		
	Boys	Girls	Total	Boys	Girls	Total								
Below 7	39811	31887	71698											
7	330706	289581	620287				898970	874178	1773147	36.8	33.1	35.0		
8	473992	405775	879767				873996	848677	1722673	54.2	47.8	51.1		
9	470578	382890	853468				856393	830688	1687081	54.9	46.1	50.6		
10	613871	485895	1099766				843526	817513	1661038	72.8	59.4	66.2		
11	506016	376816	882832				832179	805902	1638081	60.8	46.8	53.9		
12	569110	385695	954805				819468	793019	1612487	69.4	48.6	59.2		
13	542251	349659	891910				803843	777380	1581223	67.5	45.0	56.4		
14	455864	262964	718828				786062	759754	1545816	58.0	34.6	46.5		
Above 14	726251	283150	1009401											
Total(1-8)	4728450	3254310	7982760				6714436	6507111	13221547	70.4	50.0	60.4		
Below 15														
15						35363	23640	59002						
16						58168	40825	98992	768883	742931	1511814	7.6	5.5	6.5
Above 16						72234	50487	122720	752825	727490	1480315	9.6	6.9	8.3
Total						5018202	3432704	8450906	289752	178394	468146	19.0	12.1	15.6
									8236144	7977532	16213676			
Net Enrolment ratios by level				Gross Enrolment Ratios by Level				Percentage of Unenrolled Children by Level						
School Level	Boys	Girls	Total	School Level	Boys	Girls	Total		School Level	Boys	Girls	Total		
Primary (1-8)	59.0	45.2	52.2	Primary (1-8)	70.4	50.0	60.4		Primary (1-8)	29.6	50.0	39.6		
Senior Secondary (9-10)	8.6	6.2	7.4	Senior Secondary	19.0	12.1	15.6		Senior Secondary (9-10)	81.0	87.9	84.4		
Overall G.E.R	60.9	43.0	52.1	Over all percentage of unenrolled children (Overall)					39.1	57.0	47.9			

Primary (1-8) Gross Enrollment Ratios by Region and Year

Region	1990			1991			1992			1993			1994		
	Male	Female	Total	Male	Female	Total	Male	Female	Total	Male	Female	Total	Male	Female	Total
Tigray	61.7	50.2	56.1	63.0	53.8	58.4	65.8	61.2	63.5	75.9	71.8	73.9	79.1	76.0	77.6
Afar	10.0	6.8	8.4	7.4	6.5	7.1	10.2	7.7	9.1	12.7	9.8	11.5	13.9	10.8	12.6
Amhara	38.4	30.8	34.6	44.1	36.7	40.4	50.3	43.2	46.8	56.9	49.7	53.3	62.4	53.7	58.1
Oromiya	53.6	25.4	39.6	59.6	30.0	45.0	66.9	36.1	51.6	73.5	42.1	57.9	78.1	46.5	62.4
Somali	16.2	6.6	11.6	10.3	5.1	8.0	10.6	5.6	8.3	13.4	7.2	10.6	16.1	9.5	13.1
Benshangul Gumuz	95.6	43.3	69.9	99.3	49.5	74.9	105.5	57.2	81.8	112.7	63.3	88.5	111.0	66.1	89.1
SNNPR	75.8	35.2	55.7	75.6	37.7	56.8	77.4	41.9	59.8	80.8	46.7	63.8	83.8	50.9	67.5
Gambella	106.0	59.9	83.5	110.7	66.5	89.1	114.9	71.3	93.7	117.1	73.0	95.8	126.9	77.0	102.7
Harari	86.7	66.9	77.1	104.5	75.0	90.0	110.6	81.2	96.2	120.8	89.1	105.3	123.6	90.5	107.5
Addis Ababa	83.9	80.4	82.0	86.1	83.5	84.7	91.6	91.2	91.4	118.0	118.5	118.3	126.0	130.5	128.4
Dire Dawa	64.4	53.2	58.9	66.4	53.4	60.0	69.1	55.5	62.4	84.1	67.1	75.7	89.3	70.8	80.2
Total	52.0	31.2	41.8	55.9	35.3	45.8	60.9	40.7	51.0	67.3	47.0	57.4	71.7	51.2	61.6

Secondary (9-10) Gross Enrollment Ratios by Region and Year

Region	1990			1991			1992			1993			1994		
	Male	Female	Total	Male	Female	Total	Male	Female	Total	Male	Female	Total	Male	Female	Total
Tigray	11.7	5.8	8.8	15.8	7.8	11.8	24.9	12.3	18.7	40.8	26.7	33.8	46.3	30.1	38.3
Afar	1.8	1.6	1.7	2.6	2.4	2.5	2.9	2.7	2.8	3.4	3.9	3.6	4.2	4.1	4.2
Amhara	8.9	8.2	8.5	9.5	9.4	9.5	10.1	10.6	10.3	11.5	10.5	11.0	13.8	10.2	12.0
Oromiya	11.7	7.8	9.8	12.5	8.4	10.5	13.4	8.9	11.2	14.9	9.8	12.4	20.2	11.4	15.9
Somali	0.7	0.2	0.5	0.6	0.2	0.5	1.0	0.7	0.9	1.2	0.6	0.9	3.1	1.2	2.3
Benshangul Gumuz	10.8	5.2	8.0	13.0	6.6	9.8	14.6	7.5	11.1	15.8	7.7	11.8	22.8	10.2	16.6
SNNPR	13.2	6.4	9.8	15.0	7.3	11.2	14.2	7.4	10.8	12.5	6.4	9.5	17.9	8.5	13.2
Gambella	25.8	6.0	16.0	30.2	6.8	18.7	28.6	7.3	18.1	30.4	8.5	19.7	25.5	7.5	16.7
Harari	51.9	46.3	49.1	52.5	45.3	48.9	48.4	38.5	43.4	49.7	38.4	44.0	70.1	49.3	59.6
Addis Ababa	63.1	59.6	61.1	67.4	60.7	63.7	60.1	53.2	56.3	63.9	54.1	58.4	75.6	64.2	69.3
Dire Dawa	32.6	25.7	29.1	33.5	26.3	29.8	36.9	25.5	31.0	34.1	23.1	28.3	40.3	26.9	33.2
Total	12.7	9.9	11.3	13.9	10.8	12.4	14.4	11.2	12.8	16.1	12.1	14.1	20.4	13.7	17.1

Changes in the number of Primary (1-8) Enrollment over the past five years

Region	1990			1991			1992			1993			1994			Average annual growth rate (%)
	Both	Girls	% Girls	Both	Girls	% Girls	Both	Girls	% Girls	Both	Girls	% Girls	Both	Girls	% Girls	
Tigray	397943	175650	44.1	425668	193284	45.4	472834	224407	47.5	562635	268923	47.8	606202	292294	48.2	11.1
Afar	14791	5751	38.9	16943	6545	38.6	22088	7841	35.5	27832	10124	36.4	30735	11336	36.9	20.1
Amhara	1060086	467318	44.1	1274646	573016	45.0	1507124	689668	45.8	1754802	809790	46.1	1964101	899886	45.8	16.7
Oromiya	1710918	541231	31.6	1997695	659465	33.0	2341195	810581	34.6	2680868	965006	36.0	2969966	1095652	36.9	14.8
Somali	61837	17100	27.7	61837	17100	27.7	66834	20026	30.0	85840	26236	30.6	106572	35004	32.8	14.6
Benshangul-Gumuz	72725	22083	30.4	80267	26045	32.4	89777	30715	34.2	99314	34734	35.0	102024	37038	36.3	8.8
SNNPR	1331193	417468	31.4	1401489	461880	33.0	1504351	522768	34.8	1638501	594029	36.3	1784410	667530	37.4	7.6
Gambella	32572	11373	34.9	35578	12925	36.3	37421	13830	37.0	38256	14124	36.9	41539	15061	36.3	6.3
Harari	20828	8695	41.7	23757	9719	40.9	25207	10417	41.3	27379	11295	41.3	28472	11676	41.0	8.1
Addis Ababa	357729	186636	52.2	352843	184019	52.2	362921	190561	52.5	446342	233632	52.3	467164	246249	52.7	6.9
Dire Dawa	30048	13300	44.3	31510	13912	44.2	32751	14419	44.0	39704	17391	43.8	43152	18756	43.5	9.5
Total	5090670	1866605	36.7	5702233	2157910	37.8	6462503	2535233	39.2	7401473	2985284	40.3	8144337	3330482	40.9	12.5

Changes in the number of Senior Secondary (9-10) Enrollment over the past five years

Region	1990			1991			1992			1993			1994			Average annual growth rate (%)
	Both	Girls	% Girls	Both	Girls	% Girls	Both	Girls	% Girls	Both	Girls	% Girls	Both	Girls	% Girls	
Tigray	13473	4443	33.0	18690	6142	32.9	30404	9975	32.8	56725	22192	39.1	65690	25556	38.9	48.6
Afar	957	370	38.7	1433	560	39.1	1648	642	39.0	2127	929	43.7	2466	997	40.4	26.7
Amhara	57030	27033	47.4	65146	31900	49.0	72931	36875	50.6	80024	37669	47.1	89234	37468	42.0	11.8
Oromiya	92431	36509	39.5	101822	40259	39.5	111854	43959	39.3	127765	49833	39.0	166850	59286	35.5	15.9
Somali	855	179	20.9	855	179	20.9	1620	538	33.2	1752	496	28.3	4383	1020	23.3	50.5
Benshangul-Gumuz	1811	585	32.3	2287	757	33.1	2658	889	33.4	2904	934	32.2	4171	1259	30.2	23.2
SNNPR	51918	16826	32.4	60492	19492	32.2	60328	20519	34.0	53980	18048	33.4	77090	24518	31.8	10.4
Gambella	1532	283	18.5	1803	323	17.9	1772	351	19.8	1950	415	21.3	1652	363	22.0	1.9
Harari	3373	1602	47.5	3449	1611	46.7	3142	1404	44.7	3270	1441	44.1	4389	1825	41.6	6.8
Addis Ababa	80585	43049	53.4	85291	44738	52.5	76584	39997	52.2	80760	41464	51.3	91498	46834	51.2	3.2
Dire Dawa	3922	1779	45.4	4142	1894	45.7	4440	1907	43.0	4189	1799	42.9	4904	2079	42.4	5.7
Total	307887	132658	43.1	345410	147855	42.8	367381	157056	42.8	415446	175220	42.2	512327	201205	39.3	13.6

Changes in the number of Primary (1-8) Teachers over the past five years

Region	1990			1991			1992			1993			1994			Average annual growth rate (%)
	Both	Female	%Female	Both	Female	%Female	Both	Female	%Female	Both	Female	% Girls	Both	Female	% Girls	
Tigray	7682	2983	38.8	7672	3003	39.1	7671	2999	39.1	8219	3341	40.6	8524	3474	40.8	2.6
Afar	662	133	20.1	650	135	20.8	795	183	23.0	918	217	23.6	938	226	24.1	9.1
Amhara	22749	6490	28.5	23196	6694	28.9	24401	7918	32.4	26029	9152	35.2	27930	10177	36.4	5.3
Oromiya	40593	10416	25.7	42286	11378	26.9	43900	12388	28.2	44249	12752	28.8	44905	13207	29.4	2.6
Somali	3053	498	16.3	3053	498	16.3	1820	318	17.5	2396	405	16.9	2396	405	16.9	-5.9
Benshangul-Gumuz	1561	398	25.5	1587	427	26.9	1805	557	30.9	1961	592	30.2	1946	627	32.2	5.7
SNNPR	22972	4952	21.6	23683	5227	22.1	24692	5572	22.6	25943	5944	22.9	26931	6206	23.0	4.1
Gambella	843	229	27.2	952	222	23.3	1068	240	22.5	1064	231	21.7	1054	197	18.7	5.7
Harari	867	386	44.5	963	409	42.5	981	430	43.8	1152	501	43.5	1132	503	44.4	6.9
Addis Ababa	7538	3034	40.2	7615	3076	40.4	7883	3165	40.1	8344	3293	39.5	10207	4147	40.6	7.9
Dire Dawa	717	234	32.6	748	233	31.1	761	233	30.6	802	247	30.8	919	283	30.8	6.4
	109237	29753	27.2	112405	31302	27.8	115777	34003	29.4	121077	36675	30.3	126882	39452	31.1	3.8

Changes in the number of Senior Secondary (9-12) Teachers over the past five years

Region	1990			1991			1992			1993			1994			Average annual growth rate (%)
	Both	Female	%Female	Both	Female	%Female	Both	Female	%Female	Both	Girls	% Girls	Both	Girls	% Girls	
Tigray	565	47	8.3	597	43	7.2	661	45	6.8	945	85	9.0	847	82	9.7	10.7
Afar	93	4	4.3	79	4	5.1	112	3	2.7	121	2	1.7	63	1	1.6	-9.3
Amhara	2172	142	6.5	2286	162	7.1	2269	125	5.5	2415	120	5.0	2725	136	5.0	5.8
Oromiya	4185	284	6.8	4611	328	7.1	4605	331	7.2	4741	339	7.2	4874	312	6.4	3.9
Somali	86	2	2.3	86	2	2.3	124	4	3.2	158	4	2.5	158	4	2.5	16.4
Benshangul-Gumuz	120	6	5.0	164	9	5.5	130	5	3.8	166	8	4.8	253	11	4.3	20.5
SNNPR	2175	139	6.4	2292	166	7.2	2284	163	7.1	2454	185	7.5	1904	149	7.8	-3.3
Gambella	77	4	5.2	92	6	6.5	87	7	8.0	78	4	5.1	69	2	2.9	-2.7
Harari	152	16	10.5	164	15	9.1	167	15	9.0	173	17	9.8	202	18	8.9	7.4
Addis Ababa	2568	403	15.7	2558	376	14.7	2544	392	15.4	2615	372	14.2	2823	371	13.1	2.4
Dire Dawa	136	8	5.9	149	11	7.4	171	11	6.4	163	10	6.1	173	8	4.6	6.2
Total	12329	1055	8.6	13078	1122	8.6	13154	1101	8.4	14029	1146	8.2	14091	1094	7.8	3.4

Changes in the number of Primary (1-8) Schools over the past five years

Region	1990	1991	1992	1993	1994	Average annual growth rate (%)
Tigray	790	811	852	888	926	4.1
Afar	80	101	124	131	142	15.4
Amhara	2760	2819	2895	2928	2975	1.9
Oromiya	4067	4200	4359	4468	4592	3.1
Somali	167	167	222	250	272	13.0
Benshangul-Gumuz	254	257	272	285	275	2.0
SNNPR	2192	2228	2271	2305	2352	1.8
Gambella	110	123	129	136	143	6.8
Harari	43	44	46	46	48	2.8
Addis Ababa	240	248	267	287	303	6.0
Dire Dawa	49	53	53	56	61	5.6
Total	10752	11051	11490	11780	12089	3.0

Changes in the number of Senior Secondary (9-12) Schools over the past five years

Region	1990	1991	1992	1993	1994	Average annual growth rate (%)
Tigray	23	26	31	37	41	15.5
Afar	3	4	5	6	7	23.6
Amhara	84	81	81	81	85	0.3
Oromiya	126	128	129	133	139	2.5
Somali	3	3	9	10	14	47.0
Benshangul-Gumuz	9	9	10	10	12	7.5
SNNPR	80	81	83	84	84	1.2
Gambella	6	6	6	6	7	3.9
Harari	3	3	3	4	4	7.5
Addis Ababa	41	41	49	49	58	9.1
Dire Dawa	4	4	4	4	4	0.0
Total	382	386	410	424	455	4.5

Changes in the number of Primary (1-8) Sections over the past five years

Region	1990	1991	1992	1993	1994	Average annual growth rate (%)
Tigray	6653	6849	7308	8043	9023	7.9
Afar	356	424	530	602	695	18.2
Amhara	20228	21593	23778	24558	25657	6.1
Oromiya	29793	32409	35187	38167	40177	7.8
Somali	900	900	1248	1474	1474	13.1
Benshangul-Gumuz	1341	1463	1490	1616	1735	6.7
SNNPR	19318	19501	20611	21282	22224	3.6
Gambella	583	639	687	675	654	2.9
Harari	458	494	539	556	514	2.9
Addis Ababa	5038	5220	5393	5774	6115	5.0
Dire Dawa	469	518	544	563	620	7.2
Total	85137	90010	97315	103310	108888	6.3

Changes in the number of Senior Secondary (9-12) Sections over the past five years

Region	1990	1991	1992	1993	1994	Average annual growth rate (%)
Tigray	320	386	515	801	903	29.6
Afar	23	28	36	42	32	8.6
Amhara	1230	1383	1443	1518	1556	6.1
Oromiya	2181	2342	2417	2692	2835	6.8
Somali	29	29	40	41	39	7.7
Benshangul-Gumuz	58	74	69	76	91	11.9
SNNPR	1113	1181	1210	1190	1271	3.4
Gambella	36	43	36	44	36	0.0
Harari	94	97	87	88	80	-4.0
Addis Ababa	1689	1720	1682	1717	1484	-3.2
Dire Dawa	87	91	100	90	93	1.7
Total	6860	7374	7635	8299	8420	5.3

Pupil Teacher (PTR) and Pupil Section (PSR) Ratios by Level 1990 E.C.(1997/98)

Region	Primary (1-8)					Senior Secondary (9-12)				
	Pupil	Teachers	Sections	PTR	PSR	Pupil	Teachers	Sections	PTR	PSR
Tigray	397943	7682	6653	52	60	20686	565	320	37	65
Afar	14791	662	356	22	42	1241	93	23	13	54
Amhara	1060086	22749	20228	47	52	86832	2172	1230	40	71
Oromiya	1710918	40593	29793	42	57	136852	4185	2181	33	63
Somali	61837	3053	900	20	69	1287	86	29	15	44
Benshangul-Gumuz	72725	1561	1341	47	54	2742	120	58	23	47
SNNPR	1331193	22972	19318	58	69	77496	2175	1113	36	70
Gambella	32572	843	583	39	56	2362	77	36	31	66
Harari	20828	867	458	24	45	5763	152	94	38	61
Addis Ababa	357729	7538	5038	47	71	126582	2568	1689	49	75
Dire Dawa	30048	717	469	42	64	5826	136	87	43	67
Total	5090670	109237	85137	47	60	467669	12329	6860	38	68

Pupil Teacher (PTR) and Pupil Section (PSR) Ratios by Level 1991 E.C.(1998/99)

Region	Primary (1-8)					Senior Secondary (9-12)				
	Pupil	Teachers	Sections	PTR	PSR	Pupil	Teachers	Sections	PTR	PSR
Tigray	425668	7672	6849	55	62	26744	597	386	45	69
Afar	16943	650	424	26	40	1818	79	28	23	65
Amhara	1274646	23196	21593	55	59	98428	2286	1383	43	71
Oromiya	1997695	42286	32409	47	62	153481	4611	2342	33	66
Somali	61837	3053	900	20	69	1287	86	29	15	44
Benshangul-Gumuz	80267	1587	1463	51	55	3432	164	74	21	46
SNNPR	1401489	23683	19501	59	72	90527	2292	1181	39	77
Gambella	35578	952	639	37	56	2837	92	43	31	66
Harari	23757	963	494	25	48	6080	164	97	37	63
Addis Ababa	352843	7615	5220	46	68	130700	2558	1720	51	76
Dire Dawa	31510	748	518	42	61	6394	149	91	43	70
Total	5702233	112405	90010	51	63	521728	13078	7374	40	71

Pupil Teacher (PTR) and Pupil Section (PSR) Ratios by Level 1992 E.C.(1999/2000)

Region	Primary (1-8)					Senior Secondary (9-12)				
	Pupil	Teachers	Sections	PTR	PSR	Pupil	Teachers	Sections	PTR	PSR
Tigray	472834	7671	7308	62	65	40197	661	515	61	78
Afar	22088	795	530	28	42	2614	112	36	23	73
Amhara	1507124	24401	23778	62	63	110970	2269	1443	49	77
Oromiya	2341195	43900	35187	53	67	173932	4605	2417	38	72
Somali	66834	1820	1248	37	54	2397	124	40	19	60
Benshangul-Gumuz	89777	1805	1490	50	60	4012	130	69	31	58
SNNPR	1504351	24692	20611	61	73	94368	2284	1210	41	78
Gambella	37421	1068	687	35	54	3011	87	36	35	84
Harari	25207	981	539	26	47	5845	167	87	35	67
Addis Ababa	362921	7883	5393	46	67	127122	2544	1682	50	76
Dire Dawa	32751	761	544	43	60	7251	171	100	42	73
Total	6462503	115777	97315	56	66	571719	13154	7635	43	75

Pupil Teacher (PTR) and Pupil Section (PSR) Ratios by Level 1993 E.C.(2000/2001)

Region	Primary (1-8)					Senior Secondary (9-12)				
	Pupil	Teachers	Sections	PTR	PSR	Pupil	Teachers	Sections	PTR	PSR
Tigray	551375	8219	8043	67	69	66467	945	801	70	83
Afar	26476	918	602	29	44	3368	121	42	28	80
Amhara	1747312	26029	24558	67	71	120412	2415	1518	50	79
Oromiya	2661980	44249	38167	60	70	200799	4741	2692	42	75
Somali	83249	2396	1474	35	56	2516	158	41	16	61
Benshangul-Gumuz	97633	1961	1616	50	60	4792	166	76	29	63
SNNPR	1628979	25943	21282	63	77	100671	2454	1190	41	85
Gambella	38256	1064	675	36	57	3093	78	44	40	70
Harari	26513	1152	556	23	48	6270	173	88	36	71
Addis Ababa	377291	8344	5774	45	65	133026	2615	1717	51	77
Dire Dawa	35057	802	563	44	62	7807	163	90	48	87
Total	7274121	121077	103310	60	70	649221	14029	8299	46	78

Pupil Teacher (PTR) and Pupil Section (PSR) Ratios by Level 1994 E.C.(2001/02) (Regular)

Region	Primary (1-8)					Senior Secondary (9-12)				
	Pupil	Teachers	Sections	PTR	PSR	Pupil	Teachers	Sections	PTR	PSR
Tigray	588941	8524	9023	69	65	72280	847	903	85	80
Afar	29124	938	695	31	42	3455	63	32	55	108
Amhara	1948048	27930	25657	70	76	119986	2725	1556	44	77
Oromiya	2946790	44905	40177	66	73	225274	4874	2835	46	79
Somali	106572	2396	1474	44	72	5253	158	39	33	135
Benshangul-Gumuz	102009	1946	1735	52	59	5977	253	91	24	66
SNNPR	1770419	26931	22224	66	80	114527	1904	1271	60	90
Gambella	40497	1054	654	38	62	2069	69	36	30	57
Harari	27271	1132	514	24	53	6402	202	80	32	80
Addis Ababa	385093	10207	6115	38	63	122421	2823	1484	43	82
Dire Dawa	37996	919	620	41	61	6986	173	93	40	75
Total	7982760	126882	108888	63	73	684630	14091	8420	49	80

Certified Secondary School teachers(9-12) by Region and Sex: 1994 E.C. (2001/02)

Region	Total Secondary School Teachers			Total Degree&above Graduate Teachers			% Qualified Teachers		
	Male	Female	Total	Male	Female	Total	Male	Female	Total
Tigray	765	82	847	88	6	94	11.5	7.3	11.1
Afar	62	1	63	25		25	40.3		39.7
Amhara	2589	136	2725	1171	42	1213	45.2	30.9	44.5
Oromiya	4562	312	4874	1379	54	1433	30.2	17.3	29.4
Somali	154	4	158	51		51	33.1		32.3
Benshangul-Gumuz	242	11	253	83	2	85	34.3	18.2	33.6
SNNPR	1755	149	1904	285	24	309	16.2	16.1	16.2
Gambella	67	2	69	21	1	22	31.3	50.0	31.9
Harari	184	18	202	121	6	127	65.8	33.3	62.9
Addis Ababa	2452	371	2823	1126	150	1276	45.9	40.4	45.2
Dire Dawa	165	8	173	113	3	116	68.5	37.5	67.1
Ethiopia	12997	1094	14091	4463	288	4751	34.3	26.3	33.7

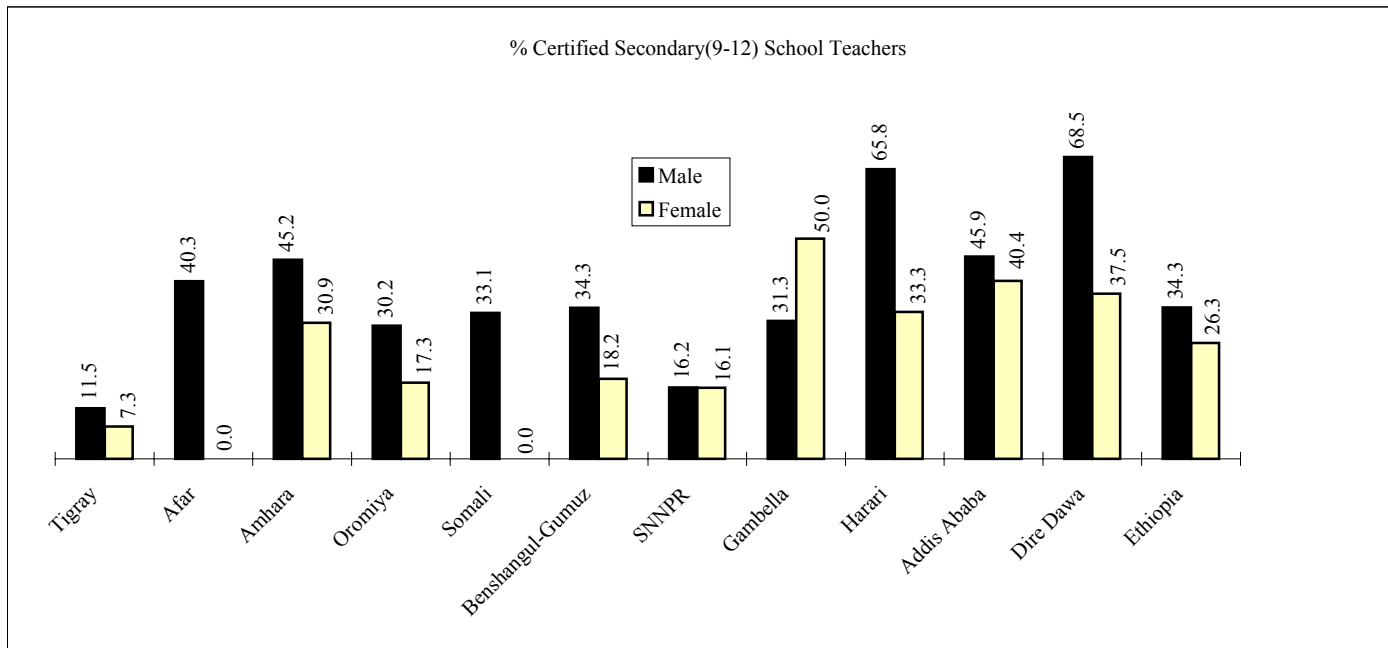

Certified Primary School teachers (1-4) by Region and Sex: 1994 E.C. (2001/02)

Region	Primary(1-4) Teachers			Teachers with TTI Certificate (1)			Teachers with over TTI certificate (2)			Total Certified Teachers (1+2)			% Qualified Teachers		
	Male	Female	Total	Male	Female	Total	Male	Female	Total	Male	Female	Total	Male	Female	Total
Tigray	2897	2938	5835	2530	2634	5164	268	240	508	2798	2874	5672	96.6	97.8	97.2
Afar	479	204	683	373	171	544	20	6	26	393	177	570	82.0	86.8	83.5
Amhara	10422	8707	19129	9574	7518	17092	391	606	997	9965	8124	18089	95.6	93.3	94.6
Oromiya	16482	11123	27605	15720	10937	26657	264	69	333	15984	11006	26990	97.0	98.9	97.8
Somali	1237	297	1534	702	188	890	431	85	516	1133	273	1406	91.6	91.9	91.7
Benshangul-Gumuz	1004	578	1582	978	560	1538	12	12	24	990	572	1562	98.6	99.0	98.7
SNNPR	11435	4791	16226	10020	4314	14334	961	320	1281	10981	4634	15615	96.0	96.7	96.2
Gambella	564	139	703	467	118	585	17	1	18	484	119	603	85.8	85.6	85.8
Harari	255	374	629	221	359	580	27	7	34	248	366	614	97.3	97.9	97.6
Addis Ababa	2116	2566	4682	1264	1900	3164	474	390	864	1738	2290	4028	82.1	89.2	86.0
Dire Dawa	321	235	556	275	211	486	42	20	62	317	231	548	98.8	98.3	98.6
Ethiopia	47212	31952	79164	42124	28910	71034	2907	1756	4663	45031	30666	75697	95.4	96.0	95.6

Certified Primary School teachers (5-8) by Region and Sex: 1994 E.C. (2001/02)

Region	Primary(5-8) Teachers			Teachers with TTC and Diploma (1)			Teachers with 12+2 & above (2)			Total Certified Teachers (1+2)			% Qualified Teachers		
	Male	Female	Total	Male	Female	Total	Male	Female	Total	Male	Female	Total	Male	Female	Total
Tigray	2153	536	2689	842	139	981	53	5	58	895	144	1039	41.6	26.9	38.6
Afar	233	22	255	138	8	146	3	0	3	141	8	149	60.5	36.4	58.4
Amhara	7331	1470	8801	2473	494	2967	48	16	64	2521	510	3031	34.4	34.7	34.4
Oromiya	15216	2084	17300	1677	335	2012	196	35	231	1873	370	2243	12.3	17.8	13.0
Somali	754	108	862	22	0	22	12	2	14	34	2	36	4.5	1.9	4.2
Benshangul-Gumuz	315	49	364	151	13	164	5	2	7	156	15	171	49.5	30.6	47.0
SNNPR	9290	1415	10705	1428	267	1695	183	30	213	1611	297	1908	17.3	21.0	17.8
Gambella	293	58	351	78	12	90	1	0	1	79	12	91	27.0	20.7	25.9
Harari	374	129	503	125	18	143	23	0	23	148	18	166	39.6	14.0	33.0
Addis Ababa	3944	1581	5525	241	34	275	2007	886	2893	2248	920	3168	57.0	58.2	57.3
Dire Dawa	315	48	363	133	13	146	36	2	38	169	15	184	53.7	31.3	50.7
Ethiopia	40218	7500	47718	7308	1333	8641	2567	978	3545	9875	2311	12186	24.6	30.8	25.5

Total Primary and Secondary Level Enrollment by Year

<i>Year E.C.</i>	<i>Primary (1-8)</i>	<i>Secondary (9-12)</i>	<i>Year G.C.</i>
1990	5,090,670	467,669	1997/98
1991	5,702,233	521,728	1998/99
1992	6,462,503	571,719	1999/00
1993	7,401,473	736,174	2000/01
1994	8,144,337	764,641	2001/02

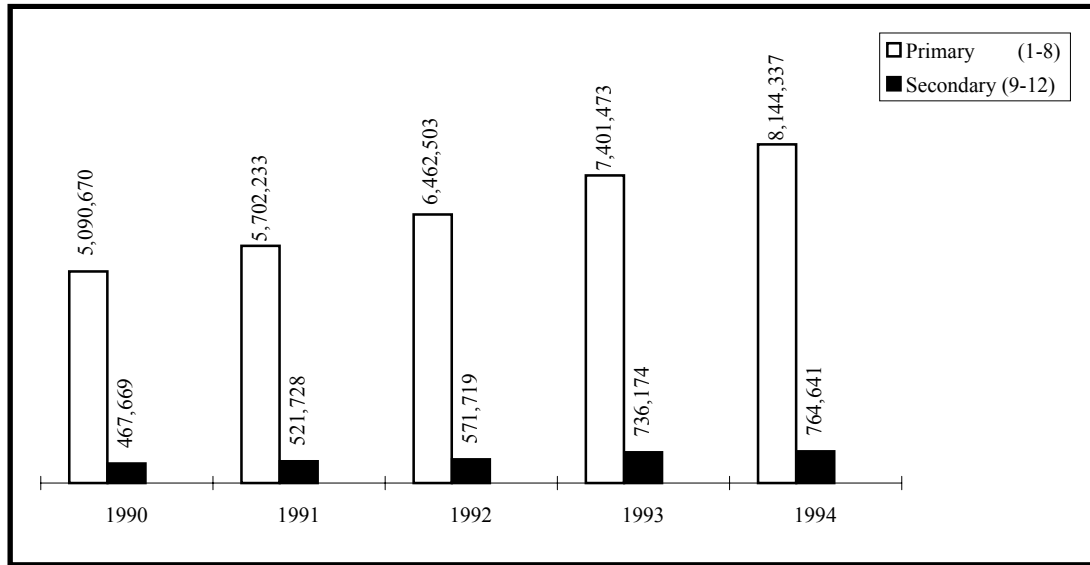

Total Primary and Secondary Level Teachers by year

<i>Year E.C.</i>	<i>Primary (1-8)</i>	<i>Senior Secondary (9-12)</i>	<i>Year G.C.</i>
1990	109,237	12,329	1997/98
1991	112,405	13,078	1998/99
1992	115,777	13,154	1999/00
1993	121,077	14,029	2000/01
1994	126,882	14,091	2001/02

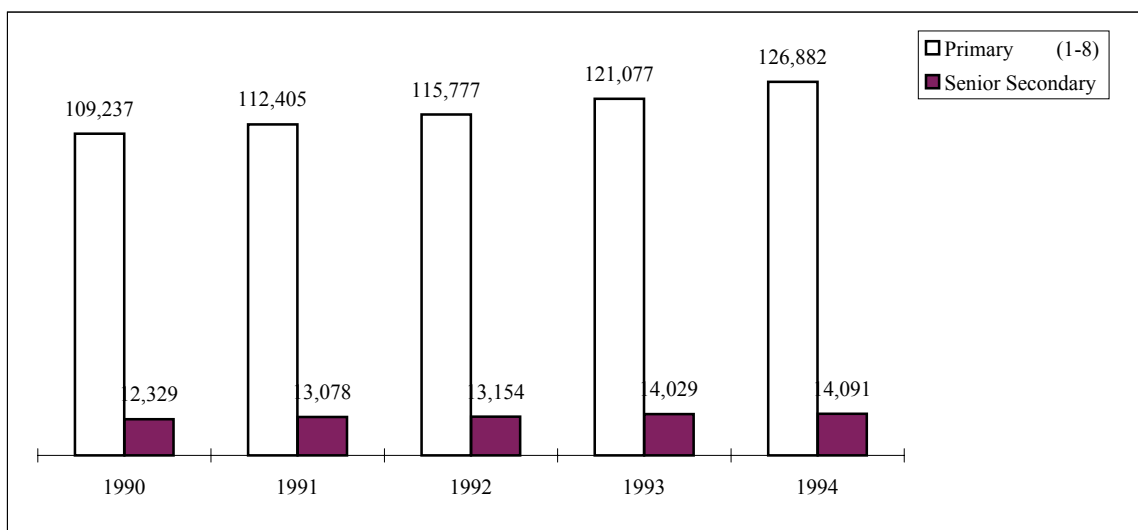

Primary and Secondary Level Schools by year

<i>Year E.C.</i>	<i>Primary (1-8)</i>	<i>Senior Secondary (9-12)</i>	<i>Year G.C.</i>
1990	10,752	382	1997/98
1991	11,051	386	1998/99
1992	11,490	410	1999/00
1993	11,780	424	2000/01
1994	12,087	455	2001/02

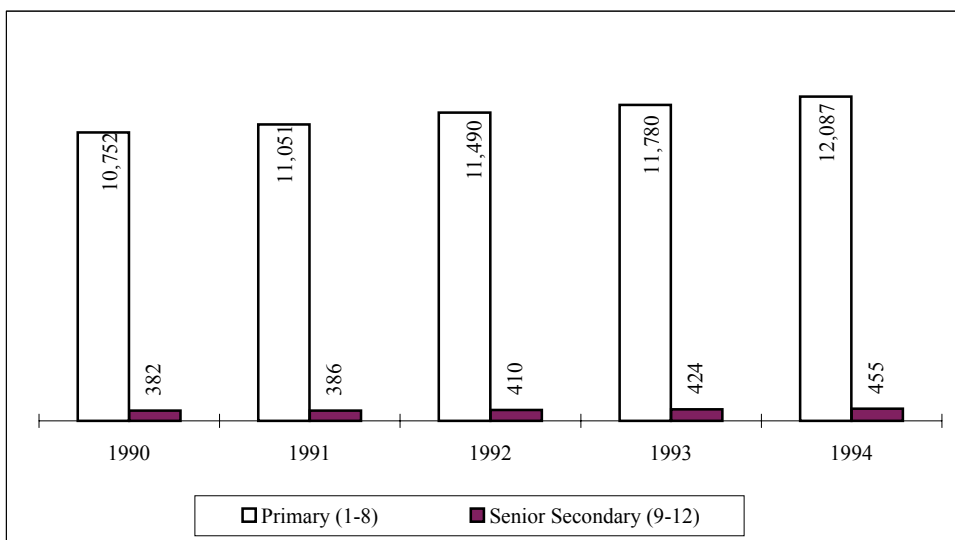

Primary and Secondary Level Sections by year

<i>Year E.C.</i>	<i>Primary (1-8)</i>	<i>Senior Secondary (9-12)</i>	<i>Year G.C.</i>
1990	85,137	6,860	1997/98
1991	89,937	7,258	1998/99
1992	97,315	7,635	1999/00
1993	103,310	8,299	2000/01
1994	108,888	8,577	2001/02

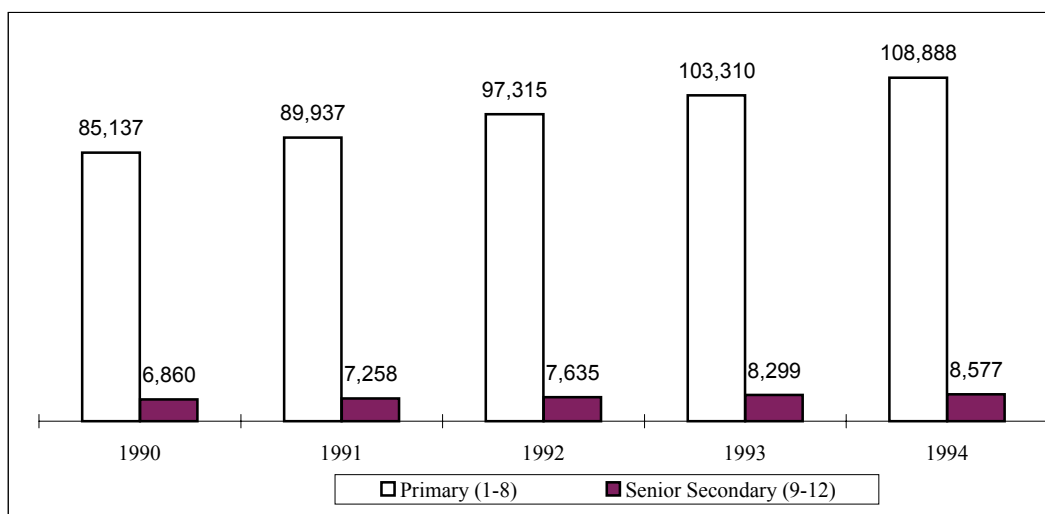

Trend of Students Enrolled in Institutions of Higher Education by Program Level

Diploma (Enrollment)

Year E.C.	Regular		Evening		Kiremt		Total		Year G.C.
	BS	F	BS	F	BS	F	BS	F	
1990	6088	1128	14014	3810	1562	185	21664	5123	1997/98
1991	6524	1687	15142	3896	2079	335	23745	5918	1998/99
1992*	14961	4470	19034	5277	1720	236	35715	9983	1999/00
1993*	22206	6158	25465	6605	3885	631	51556	13394	2000/01
1994*	24640	10191	36852	10396	4434	723	65926	21310	2001/02

Undergraduate Degree (Enrollment)

Year E.C.	Regular		Evening		Kiremt		Total		Year G.C.
	BS	F	BS	F	BS	F	BS	F	
1990	16648	2196	5796	1306	579	17	23023	3519	1997/98
1991	19957	2308	5443	1365	2296	116	27696	3789	1998/99
1992	21265	2813	6561	1598	3172	184	30998	4595	1999/00
1993	23320	3436	6938	1499	4331	281	34589	5216	2000/01
1994	22156	3326	7715	1856	4685	307	34556	5489	2001/02

Postgraduate Degree(Enrollment)

Year E.C.	BS	F	Year G.C.
1990	867	60	1997/98
1991	864	62	1998/99
1992	969	69	1999/00
1993	1286	97	2000/01
1994	1347	99	2001/02

Graduates (diploma+under G.degree+post G.degree)

Year E.C.	Regular		Evening		Kiremt		Total		Year G.C.
	BS	F	BS	F	BS	F	BS	F	
1990	5003	663	2562	852	428	29	7993	1544	1997/98
1991	5460	768	2851	908	244	9	8555	1685	1998/99
1992*	8360	1587	3094	877	173	6	11627	2470	1999/00
1993*	11331	2240	5327	1430	1311	184	17969	3854	2000/01
1994*	11917	2758	6025	1567	433	49	18375	4374	2001/02

Trend of Teaching Staff in Regular Programmes of Higher Education and Percentage of Females

Year E.C.	Ethiopian			Expatriate			Total			Year G.C.
	BS	F	%F	BS	F	%F	BS	F	%F	
1990	1823	87	4.8	138	17	12.3	1961	104	5.3	1997/98
1991	2094	124	5.9	134	13	9.7	2228	137	6.1	1998/99
1992*	2350	130	5.5	153	22	14.4	2503	152	6.1	1999/00
1993*	3022	210	6.9	210	36	17.1	3232	246	7.6	2000/01
1994*	3150	228	7.2	163	22	13.5	3313	250	7.5	2001/02

BS = Both Sexes F = Female

* Data includes TTCs and Non-Government Institutions

Enrollment by grade, Government and Non-Government Primary Schools 1990 E.C (1997/1998)

Grade	1		2		3		4		5		6		7		8		Total		Grand Total	Girls %
	Boys	Girls	Boys	Girls	Boys	Girls	Boys	Girls	Boys	Girls	Boys	Girls	Boys	Girls	Boys	Girls	Boys	Girls		
Tigray	62615	57534	30304	25566	27047	23208	25403	22197	22333	16298	22894	14326	20990	11229	10707	5292	222293	175650	397943	44.1
Afar	3155	1519	1188	619	935	727	845	610	773	599	907	752	751	559	486	366	9040	5751	14791	38.9
Amhara	218797	186697	123096	92130	92413	67072	51511	36772	39285	28218	27384	20187	22888	20276	17394	15966	592768	467318	1060086	44.1
Oromiya	412716	205571	240066	98684	173373	65863	119150	48797	82713	36938	52981	27095	48752	32070	39936	26213	1169687	541231	1710918	31.6
Somalia	14523	5518	9496	3885	6194	2550	5798	2115	4578	1571	3167	1046	631	255	350	160	44737	17100	61837	27.7
Benshangul_Gumuz	20503	11100	10317	4397	7231	2520	4995	1567	3166	977	1986	572	1493	571	951	379	50642	22083	72725	30.4
SNNPR	316896	161453	173220	80163	138299	58563	100080	40005	67166	26392	45395	18450	39254	17756	33415	14686	913725	417468	1331193	31.4
Gambella	6418	4335	3664	2300	3042	1833	2604	1376	1908	632	1231	361	1158	285	1174	251	21199	11373	32572	34.9
Harari	3303	2310	2535	1441	1446	891	1115	793	1006	818	856	708	1016	874	856	860	12133	8695	20828	41.7
Addis Ababa	23150	25319	21212	22539	21857	23434	22657	23853	22647	23895	19350	20520	19410	21700	20810	25376	171093	186636	357729	52.2
Dire Dawa	4725	3443	3048	2074	1748	1341	1613	1444	1541	1302	1239	1139	1403	1197	1431	1360	16748	13300	30048	44.3
Total	1086801	664799	618146	333798	473585	248002	335771	179529	247116	137640	177390	105156	157746	106772	127510	90909	3224065	1866605	5090670	36.7

Enrollment by grade, Government and Non-Government Primary Schools 1991 E.C (1998/1999)

Grade	1		2		3		4		5		6		7		8		Total		Grand Total	Girls %
	Boys	Girls	Boys	Girls	Boys	Girls	Boys	Girls	Boys	Girls	Boys	Girls	Boys	Girls	Boys	Girls	Boys	Girls		
Tigray	49595	48013	41815	38806	29197	23757	26990	23858	22587	18275	21033	14807	21509	14373	19658	11395	232384	193284	425668	45.4
Afar	3279	1959	1477	935	1256	757	1143	656	998	617	683	497	844	660	718	464	10398	6545	16943	38.6
Amhara	240966	226454	138461	109673	108054	79658	82403	56603	48963	36246	35003	24587	27718	22481	20062	17314	701630	573016	1274646	45.0
Oromiya	438204	254538	262493	124584	204649	83696	149746	57639	109466	44792	72975	31947	56786	33710	43911	28559	1338230	659465	1997695	33.0
Somalia	14523	5518	9496	3885	6194	2550	5798	2115	4578	1571	3167	1046	631	255	350	160	44737	17100	61837	27.7
Benshangul_Gumuz	17353	10986	11774	5845	8722	3609	6256	2232	4246	1420	2835	812	1933	763	1103	378	54222	26045	80267	32.4
SNNPR	288495	165437	174391	88676	143052	66530	116418	50010	83204	33818	54903	21859	45357	20674	33789	14876	939609	461880	1401489	33.0
Gambella	6538	4450	3712	2425	3226	2158	2848	1767	2292	1056	1528	453	1229	302	1280	314	22653	12925	35578	36.3
Harari	4041	3081	2315	1500	2156	1169	1412	782	1185	839	936	697	1091	900	902	751	14038	9719	23757	40.9
Addis Ababa	23773	25460	20253	22524	20798	22376	22950	24607	22658	24340	19716	21309	21476	23965	17200	19438	168824	184019	352843	52.2
Dire Dawa	4298	3224	3046	2296	2674	1848	1675	1368	1677	1394	1387	1251	1491	1207	1350	1324	17598	13912	31510	44.2
Total	1091065	749120	669233	401149	529978	288108	417639	221637	301854	164368	214166	119265	180065	119290	140323	94973	3544323	2157910	5702233	37.8

Enrollment by grade, Government and Non-Government Primary Schools 1992 E.C (1999/2000)

Grade	1		2		3		4		5		6		7		8		Total		Grand Total	Girls %
	Boys	Girls	Boys	Girls	Boys	Girls	Boys	Girls	Boys	Girls	Boys	Girls	Boys	Girls	Boys	Girls	Boys	Girls		
Tigray	60315	60434	36634	35705	37131	34275	27268	23698	24197	21560	20971	16996	20222	14714	21689	17025	248427	224407	472834	47.5
Afar	6500	3117	1944	1018	1274	797	1150	777	986	604	825	493	907	629	661	406	14247	7841	22088	35.5
Amhara	251437	244908	166203	147928	122676	96856	98211	70320	76645	53547	43321	30728	34958	26202	24005	19179	817456	689668	1507124	45.8
Oromiya	437711	278115	315900	179340	234284	111670	187028	79696	137519	53827	95184	39234	73627	37275	49361	31424	1530614	810581	2341195	34.6
Somalia	16677	7528	9139	4282	6161	2989	5176	1995	3411	1219	2529	859	2395	744	1320	410	46808	20026	66834	30.0
Benshangul_Gumuz	17469	11541	10925	6441	9746	4821	7849	3260	5417	1940	3393	1211	2763	1035	1500	466	59062	30715	89777	34.2
SNNPR	296678	188799	167341	93841	146923	75221	120025	56469	95941	41310	65371	26423	53892	23952	35412	16753	981583	522768	1504351	34.8
Gambella	6831	4751	3526	2373	3274	2023	2955	1929	2663	1510	1748	618	1324	359	1270	267	23591	13830	37421	37.0
Harari	3377	2719	2581	1870	2113	1279	1966	1093	1460	853	1107	775	1113	921	1073	907	14790	10417	25207	41.3
Addis Ababa	23602	25985	20883	22707	20089	22441	22494	24261	23071	25674	20642	22118	21972	24694	19607	22681	172360	190561	362921	52.5
Dire Dawa	3789	2752	2976	2266	2750	2098	2478	1836	1611	1234	1517	1314	1655	1478	1556	1441	18332	14419	32751	44.0
Total	1124386	830649	738052	497771	586421	354470	476600	265334	372921	203278	256608	140769	214828	132003	157454	110959	3927270	2535233	6462503	39.2

Enrollment by grade, Government and Non-Government Primary Schools 1993 E.C (2000/01)

Grade	1		2		3		4		5		6		7		8		Total		Grand Total	Girls %
	Boys	Girls	Boys	Girls	Boys	Girls	Boys	Girls	Boys	Girls	Boys	Girls	Boys	Girls	Boys	Girls	Boys	Girls		
Tigray	74463	73991	48530	48542	38155	35558	37385	34611	27309	23235	24255	19976	22958	18105	20657	14905	293712	268923	562635	47.8
Afar	6510	3336	3230	1719	1913	1129	1461	968	1317	879	1077	665	1163	832	1037	596	17708	10124	27832	36.4
Amhara	256504	250061	189035	176725	149493	128760	113575	87296	93017	66433	66906	44282	45358	33346	31124	22887	945012	809790	1754802	46.1
Oromiya	439072	300857	328781	205586	278973	154974	218942	107107	169568	70467	121212	47645	96719	44625	62595	33745	1715862	965006	2680868	36.0
Somalia	20342	9436	11298	5144	7933	3816	6968	3012	4742	1864	3439	1445	3084	970	1798	549	59604	26236	85840	30.6
Benshangul_Gumuz	18315	12230	11570	6915	9723	5351	8285	4109	6461	2606	4258	1480	4020	1432	1948	611	64580	34734	99314	35.0
SNNPR	307484	210916	169597	104267	148578	82152	128514	64614	102611	48171	79358	34355	66552	29949	41778	19605	1044472	594029	1638501	36.3
Gambella	5864	4377	3647	2288	3108	1941	3220	1932	2938	1790	2022	853	1619	539	1714	404	24132	14124	38256	36.9
Harari	3269	2672	2190	1745	2475	1682	2025	1255	2001	1086	1411	871	1442	1036	1271	948	16084	11295	27379	41.3
Addis Ababa	27703	32046	27446	30840	25825	27882	26890	28980	27034	28935	25070	26772	27133	28936	25609	29241	212710	233632	446342	52.3
Dire																				

Enrollment by grade, Government Primary Schools 1990 E.C (1997/1998)

Region	Grade 1		Grade 2		Grade 3		Grade 4		Grade 5		Grade 6		Grade 7		Grade 8		Total		Grand Total	Girls %
	Boys	Girls	Boys	Girls	Boys	Girls	Boys	Girls	Boys	Girls	Boys	Girls	Boys	Girls	Boys	Girls	Boys	Girls		
Tigray	61534	56531	29677	24888	26421	22549	24775	21623	21887	15870	22413	13934	20553	10904	10427	5020	217687	171319	389006	44.0
Afar	3155	1519	1188	619	935	727	845	610	773	599	907	752	751	559	486	366	9040	5751	14791	38.9
Amhara	217965	185918	122472	91494	91860	66520	51040	36278	38922	27847	27062	19913	22641	20028	17286	15838	589248	463836	1053084	44.0
Oromiya	401178	199021	233681	95152	168182	62945	115148	46271	79724	34934	50853	25420	47213	30647	38625	25059	1134604	519449	1654053	31.4
Somalia	14468	5473	9454	3831	6148	2510	5759	2079	4535	1530	3139	1023	602	233	350	160	44455	16839	61294	27.5
Benshangul_Gumuz	20079	10997	10279	4387	7231	2520	4995	1567	3166	977	1986	572	1493	571	951	379	50180	21970	72150	30.5
SNNPR	303045	154047	166441	76465	132732	55753	96032	37944	64263	25017	43221	17319	37888	16958	32414	14058	876036	397561	1273597	31.2
Gambella	6418	4335	3664	2300	3042	1833	2604	1376	1908	632	1231	361	1158	285	1174	251	21199	11373	32572	34.9
Harari	3121	2092	2339	1271	1292	739	953	651	872	704	748	608	897	787	777	780	10999	7632	18631	41.0
Addis Ababa	10008	11433	9275	10317	10489	11495	11048	12001	11965	12915	9578	10756	10986	12640	11075	13600	84424	95157	179581	53.0
Dire Dawa	4106	2907	2586	1687	1312	993	1209	1098	1142	997	948	899	1168	994	1215	1161	13686	10736	24422	44.0
Total	1045077	634273	591056	312411	449644	228584	314408	161498	229157	122022	162086	91557	145350	94606	114780	76672	3051558	1721623	4773181	36.1

Enrollment by grade, Government Primary Schools 1991 E.C (1998/1999)

Region	Grade 1		Grade 2		Grade 3		Grade 4		Grade 5		Grade 6		Grade 7		Grade 8		Total		Grand Total	Girls %
	Boys	Girls	Boys	Girls	Boys	Girls	Boys	Girls	Boys	Girls	Boys	Girls	Boys	Girls	Boys	Girls	Boys	Girls		
Tigray	48614	46989	41080	38058	28589	23097	26327	23169	22026	17704	20609	14353	20968	13923	19169	11002	227382	188295	415677	45.3
Afar	3211	1913	1453	920	1239	740	1124	638	986	606	666	475	844	660	718	464	10241	6416	16657	38.5
Amhara	240307	225759	137870	109136	107505	79117	81940	56132	48571	35833	34673	24274	27397	22182	19845	17114	698108	569547	1267655	44.9
Oromiya	426300	246695	255164	120243	198900	80568	145505	55215	106151	42648	70558	30261	55109	32239	42642	27383	1300329	635252	1935581	32.8
Somalia	14468	5473	9454	3831	6148	2510	5759	2079	4535	1530	3139	1023	602	233	350	160	44455	16839	61294	27.5
Benshangul_Gumuz	17095	10884	11535	5779	8696	3606	6256	2232	4246	1420	2835	812	1933	763	1103	378	53699	25874	79573	32.5
SNNPR	280977	161387	170194	86244	139551	64540	113500	48579	80967	32704	53115	20979	43931	19881	32711	14166	919496	448480	1363426	32.9
Gambella	6538	4450	3712	2425	3226	2158	2848	1767	2292	1056	1528	453	1229	302	1280	314	22653	19225	35578	36.3
Harari	3866	2940	2193	1377	2012	1066	1293	677	1054	726	837	618	1012	831	845	690	13112	8925	22037	40.5
Addis Ababa	9927	11447	9472	10881	9429	10638	11500	12447	11514	12750	10018	11354	11917	13793	8842	9636	82619	92946	175565	52.9
Dire Dawa	3572	2601	2567	1898	2237	1445	1220	987	1275	1070	1038	959	1201	976	1125	1135	14235	11071	25306	43.7
Total	1054875	720538	644694	380792	507532	269485	397272	203922	283617	148047	199016	105561	166143	105783	128630	82442	3381779	2016570	5398349	37.4

Enrollment by grade, Government Primary Schools 1992 E.C (1999/2000)

Region	Grade 1		Grade 2		Grade 3		Grade 4		Grade 5		Grade 6		Grade 7		Grade 8		Total		Grand Total	Girls %
	Boys	Girls	Boys	Girls	Boys	Girls	Boys	Girls	Boys	Girls	Boys	Girls	Boys	Girls	Boys	Girls	Boys	Girls		
Tigray	59264	59301	35966	35050	36509	33678	26785	23129	23756	21066	20538	16606	19898	14420	21395	16746	244111	219996	464107	47.4
Afar	6262	3038	1913	1007	1248	795	1141	776	977	600	824	492	907	629	661	406	13933	7743	21676	35.7
Amhara	250745	244131	165639	147371	122107	96331	97708	69834	76207	53085	42952	30353	34654	25905	23758	18908	813770	685918	1499688	45.7
Oromiya	423008	269896	308527	174534	228322	108112	182465	77110	134317	51832	92524	37449	71801	35779	47859	30085	1488823	784797	2273620	34.5
Somalia	16565	7401	9044	4146	6056	2883	5131	1948	3362	1174	2495	815	2358	710	1295	385	46306	19462	65768	29.6
Benshangul_Gumuz	17141	11315	10634	6273	9513	4676	7705	3168	5297	1868	3264	1141	2622	953	1436	440	57612	29834	87446	34.1
SNNPR	288656	183573	162866	91177	142960	72803	117001	54689	93582	40120	63430	25498	52488	23168	34345	16125	955328	507153	1462481	34.7
Gambella	6831	4751	3526	2373	3274	2023	2955	1929	2663	1510	1748	618	1324	359	1270	267	23591	13830	37421	37.0
Harari	3155	2520	2459	1707	1982	1155	1830	989	1320	748	999	678	1026	844	998	832	13769	9473	23242	40.8
Addis Ababa	9816	11837	9526	10944	9657	11221	10767	12162	11817	13449	10295	11319	11903	13971	9851	11348	83632	96251	179883	53.5
Dire Dawa	3406	2337	2622	1947	2446	1810	2202	1559	1327	1030	1266	1079	1414	1251	1377	1254	16060	12267	28327	43.3
Total	1084849	800100	712722	476529	564074	335487	455690	247293	354625	186482	240335	126048	200395	117989	144245	96796	3756935	2386724	6143659	38.8

Enrollment by grade, Government Primary Schools 1993 E.C (2000/01)

Region	Grade 1		Grade 2		Grade 3		Grade 4		Grade 5		Grade 6		Grade 7		Grade 8		Total		Grand Total	Girls %
	Boys	Girls	Boys	Girls	Boys	Girls	Boys	Girls	Boys	Girls	Boys	Girls	Boys	Girls	Boys	Girls	Boys	Girls		
Tigray	72979	72496	47644	47631	37437	34855	36743	33965	26854	22675	23784	19493	22561	17702	20319	14617	288321	263434	551755	47.7
Afar	6339	3274	3142	1698	1879	1118	1447	966	1311	878	1069	662	1163	832	1037	596	17387	10024	27411	36.6
Amhara	255641	249229	188370	176104	148915	128188	112944	86702	92476	65891	66444	43838	44766	32813	30634	22450	940190	805215	1745405	46.1
Oromiya	423573	290886	318976	199306	271895	150235	213263	103529	165161	67767	117979	45660	94188	42743	60559	31898	1665594	932024	2597618	35.9
Somalia	20182	9267	11139	4974	7828	3710	6850	2933	4647	1800	3357	1386	2936	914	1641	501	58580	25485	84065	30.3
Benshangul_Gumuz	17857	11882	11298	6756	9509	5204	8079	3988	6214	2482	4113	1397	3823	1343	1887	584	62780	33636	96416	34.9
SNNPR	299521	205346	164860	101180	144353	79501	125124	62578	100063	46574	77203	33187	64974	29177	40861	19037	1016959	576580	1593539	36.2
Gambella	5786	4323	3647	2288	3108	1941	3220	1932	2938	1790	2022	853	1619	539	1714	404	24054	14070	38124	36.9
Harari	2968	2396	2038	1601	2302	1502	1882	1130	1855	967	1291	752	1307	938	1195	865	14838	10151	24989	40.6
Addis Ababa	12315	15222	12704	14943	11976	13549	13403	14771	13396	15043	12543	13613	14214	15644	12381	14096	102932	116881	219813	53.2

Enrollment by grade, Non-Government Primary Schools 1990 E.C (1997/1998)

Region	Grade 1		Grade 2		Grade 3		Grade 4		Grade 5		Grade 6		Grade 7		Grade 8		Total		Grand Total	Girls %
	Boys	Girls	Boys	Girls	Boys	Girls	Boys	Girls	Boys	Girls	Boys	Girls	Boys	Girls	Boys	Girls	Boys	Girls		
Tigray	1081	1003	627	678	626	659	628	574	446	428	481	392	437	325	280	272	4606	4331	8937	48.5
Amhara	832	779	624	636	553	552	471	494	363	371	322	274	247	248	108	128	3520	3482	7002	49.7
Oromiya	11538	6550	6385	3532	5191	2918	4002	2526	2989	2004	2128	1675	1539	1423	1311	1154	35083	21782	56865	38.3
Somalia	55	45	42	54	46	40	39	36	43	41	28	23	29	22			282	261	543	48.1
Benshangul_Gumuz	424	103	38	10													462	113	575	19.7
SNNPR	13851	7406	6779	3698	5567	2810	4048	2061	2903	1375	2174	1131	1366	798	1001	628	37689	19907	57596	34.6
Harari	182	218	196	170	154	152	162	142	134	114	108	100	119	87	79	80	1134	1063	2197	48.4
Addis Ababa	13142	13886	11937	12222	11368	11939	11609	11852	10682	10980	9772	9764	8424	9060	9735	11776	86669	91479	178148	51.4
Dire Dawa	619	536	462	387	436	348	404	346	399	305	291	240	235	203	216	199	3062	2564	5626	45.6
Total	41724	30526	27090	21387	23941	19418	21363	18031	17959	15618	15304	13599	12396	12166	12730	14237	172507	144982	317489	45.7

Enrollment by grade, Non-Government Primary Schools 1991 E.C (1998/1999)

Region	Grade 1		Grade 2		Grade 3		Grade 4		Grade 5		Grade 6		Grade 7		Grade 8		Total		Grand Total	Girls %
	Boys	Girls	Boys	Girls	Boys	Girls	Boys	Girls	Boys	Girls	Boys	Girls	Boys	Girls	Boys	Girls	Boys	Girls		
Tigray	981	1024	735	748	608	660	663	689	561	571	424	454	541	450	489	393	5002	4989	9991	49.9
Afar	68	46	24	15	17	17	19	18	12	11	17	22					157	129	286	45.1
Amhara	659	695	591	537	549	541	463	471	392	413	330	313	321	299	217	200	3522	3469	6991	49.6
Oromiya	11904	7843	7329	4341	5749	3128	4241	2424	3315	2144	2417	1686	1677	1471	1269	1176	37901	24213	62114	39.0
Somalia	55	45	42	54	46	40	39	36	43	41	28	23	29	22			282	261	543	48.1
SNNPR	7518	4050	4197	2432	3501	1990	2918	1431	2237	1114	1788	880	1426	793	1078	710	24663	13400	38063	35.2
Benshangul_Gumuz	258	102	239	66	26	3											523	171	694	24.6
Harari	175	141	122	123	144	103	119	105	131	113	99	79	79	69	57	61	926	794	1720	46.2
Addis Ababa	13846	14013	10781	11643	11369	11738	11450	12160	11144	11590	9698	9955	9559	10172	8358	9802	86205	91073	177278	51.4
Dire Dawa	726	623	479	398	437	403	455	381	402	324	349	292	290	231	225	189	3363	2841	6204	45.8
Total	36190	28582	24539	20357	22446	18623	20367	17715	18237	16321	15150	13704	13922	13507	11693	12531	162544	141340	303884	46.5

Enrollment by grade, Non-Government Primary Schools 1992 E.C (1999/2000)

Region	Grade 1		Grade 2		Grade 3		Grade 4		Grade 5		Grade 6		Grade 7		Grade 8		Total		Grand Total	Girls %
	Boys	Girls	Boys	Girls	Boys	Girls	Boys	Girls	Boys	Girls	Boys	Girls	Boys	Girls	Boys	Girls	Boys	Girls		
Tigray	1051	1133	668	655	622	597	483	569	441	494	433	390	324	294	294	279	4316	4411	8727	50.5
Afar	238	79	31	11	26	2	9	1	9	4	1	1					314	98	412	23.8
Amhara	692	777	564	557	569	525	503	486	438	462	369	375	304	297	247	271	3686	3750	7436	50.4
Oromiya	14703	8219	7373	4806	5962	3558	4563	2586	3202	1995	2660	1785	1826	1496	1502	1339	41791	25784	67575	38.2
Somalia	112	127	95	136	105	106	45	47	49	45	34	44	37	34	25	25	502	564	1066	52.9
Benshangul_Gumuz	328	226	291	168	233	145	144	92	120	72	129	70	141	82	64	26	1450	881	2331	37.8
SNNPR	8022	5226	4475	2664	3963	2418	3024	1780	2359	1190	1941	925	1404	784	1067	628	26255	15615	41870	37.3
Harari	222	199	122	163	131	124	136	104	140	105	108	97	87	77	75	75	1021	944	1965	48.0
Addis Ababa	13786	14148	11357	11763	10432	11220	11727	12099	11254	12225	10347	10799	10069	10723	9756	11333	88728	94310	183038	51.5
Dire Dawa	383	415	354	319	304	288	276	277	284	204	251	235	241	227	179	187	2272	2152	4424	48.6
Total	39537	30549	25330	21242	22347	18983	20910	18041	18296	16796	16273	14721	14433	14014	13209	14163	170335	148509	318844	46.6

Enrollment by grade, Non-Government Primary Schools 1993 E.C (2000/01)

Region	Grade 1		Grade 2		Grade 3		Grade 4		Grade 5		Grade 6		Grade 7		Grade 8		Total		Grand Total	Girls %
	Boys	Girls	Boys	Girls	Boys	Girls	Boys	Girls	Boys	Girls	Boys	Girls	Boys	Girls	Boys	Girls	Boys	Girls		
Tigray	1484	1495	886	911	718	703	642	646	455	560	471	483	397	403	338	288	5391	5489	10880	50.5
Afar	171	62	88	21	34	11	14	2	6	1	8	3	0	0	0	0	321	100	421	23.8
Amhara	863	832	665	621	578	572	631	594	541	542	462	444	592	533	490	437	4822	4575	9397	48.7
Oromiya	15499	9971	9805	6280	7078	4739	5679	3578	4407	2700	3233	1985	2531	1882	2036	1847	50268	32982	83250	39.6
Somalia	160	169	159	170	105	106	118	79	95	64	82	59	148	56	157	48	1024	751	1775	42.3
Benshangul_Gumuz	458	348	272	159	214	147	206	121	247	124	145	83	197	89	61	27	1800	1098	2898	37.9
SNNPR	7963	5570	4737	3087	4225	2651	3390	2036	2548	1597	2155	1168	1578	772	917	568	27513	17449	44962	38.8
Harari	78	54	0	0	0	0	0	0	0	0	0	0	0	0	0	0	78	54	132	40.9
Addis Ababa	301	276	152	144	173	180	143	125	146	119	120	119	135	98	76	83	1246	1144	2390	47.9
Dire Dawa	15388	16824	14742	15897	13849	14333	13487	14209	13638	13892	12527	13159	12919	13292	13228	15145	109778	116751	226529	51.5
Total	42365	35601	31506	27290	26974	23442	24310	21390	22083	19599	19203	17503	18497	17125	17303	18443	202241	180393	382634	47.1

Enrollment by grade 1990 E.C (1997/1998)
Government and Non-Government Secondary Schools

Region	Grade 9		Grade 10		Grade 11		Grade 12		Total		Grand Total	Girls %
	Boys	Girls	Boys	Girls	Boys	Girls	Boys	Girls	Boys	Girls		
Tigray	5533	2813	3497	1630	3026	1389	2010	788	14066	6620	20686	32.0
Afar	361	243	226	127	131	54	68	31	786	455	1241	36.7
Amhara	18239	17519	11758	9514	11753	7557	6709	3783	48459	38373	86832	44.2
Oromiya	33866	23660	22056	12849	19989	9088	10875	4469	86786	50066	136852	36.6
Somalia	379	103	297	76	214	49	141	28	1031	256	1287	19.9
Benshagul_Gumuz	773	375	453	210	393	186	259	93	1878	864	2742	31.5
SNNPR	20851	10338	14241	6488	12288	4879	6209	2202	53589	23907	77496	30.8
Gambella	744	182	505	101	394	94	286	56	1929	433	2362	18.3
Harari	984	938	787	664	919	650	489	332	3179	2584	5763	44.8
Addis Ababa	23138	28017	14398	15032	15052	14439	9017	7489	61605	64977	126582	51.3
Dire Dawa	1271	1081	872	698	738	490	390	286	3271	2555	5826	43.9
Total	106139	85269	69090	47389	64897	38875	36453	19557	276579	191090	467669	40.9

Enrollment by grade, 1991 E.C (1998/1999)
Government and Non-Government Secondary Schools

Region	Grade 9		Grade 10		Grade 11		Grade 12		Total		Grand Total	Girls %
	Boys	Girls	Boys	Girls	Boys	Girls	Boys	Girls	Boys	Girls		
Tigray	8208	3920	4340	2222	3079	1518	2397	1060	18024	8720	26744	32.6
Afar	494	341	379	219	127	70	132	56	1132	686	1818	37.7
Amhara	19525	20304	13721	11596	12642	8935	7552	4153	53440	44988	98428	45.7
Oromiya	36452	25569	25111	14690	23499	10595	12245	5320	97307	56174	153481	36.6
Somalia	379	103	297	76	214	49	141	28	1031	256	1287	19.9
Benshagul_Gumuz	949	457	581	300	463	241	309	132	2302	1130	3432	32.9
SNNPR	25375	12583	15625	6909	14481	5383	7557	2614	63038	27489	90527	30.4
Gambella	836	203	644	120	491	114	356	73	2327	510	2837	18.0
Harari	1074	1052	764	559	1003	664	561	403	3402	2678	6080	44.0
Addis Ababa	22948	27034	17605	17704	13907	12818	10093	8591	64553	66147	130700	50.6
Dire Dawa	1352	1217	896	677	859	638	451	304	3558	2836	6394	44.4
Total	117592	92783	79963	55072	70765	41025	41794	22734	310114	211614	521728	40.6

Enrollment by grade, 1992 E.C (1999/2000)
Government and Non-Government Secondary Schools

Region	Grade 9		Grade 10		Grade 11		Grade 12		Total		Grand Total	Girls %
	Boys	Girls	Boys	Girls	Boys	Girls	Boys	Girls	Boys	Girls		
Tigray	13736	6667	6693	3308	4311	2269	1773	1440	26513	13684	40197	34.0
Afar	567	379	439	263	353	142	358	113	1717	897	2614	34.3
Amhara	21268	23709	14788	13166	14584	10509	8039	4907	58679	52291	110970	47.1
Oromiya	38769	26532	29126	17427	26998	13019	15082	6979	109975	63957	173932	36.8
Somalia	729	353	353	185	309	114	249	105	1640	757	2397	31.6
Benshagul_Gumuz	1027	560	742	329	567	227	403	157	2739	1273	4012	31.7
SNNPR	20812	11745	18997	8774	15599	6297	8793	3351	64201	30167	94368	32.0
Gambella	788	221	633	130	586	127	442	84	2449	562	3011	18.7
Harari	844	686	894	718	965	714	645	379	3348	2497	5845	42.7
Addis Ababa	18587	21092	18000	18905	16455	15668	10065	8350	63107	64015	127122	50.4
Dire Dawa	1349	858	1184	1049	1063	722	563	463	4159	3092	7251	42.6
Total	118476	92802	91849	64254	81790	49808	46412	26328	338527	233192	571719	40.8

Enrollment by grade, 1993 E.C (2000/01)
Government and Non-Government Secondary Schools

Region	Grade 9		Grade 10		Grade 11		Grade 12		Total		Grand Total	Girls %
	Boys	Girls	Boys	Girls	Boys	Girls	Boys	Girls	Boys	Girls		
Tigray	23649	17038	10884	5154	7954	4014	4021	1989	46508	28195	74703	37.7
Afar	792	624	406	305	617	383	551	187	2366	1499	3865	38.8
Amhara	28728	25811	13627	11858	18665	15794	11015	7726	72035	61189	133224	45.9
Oromiya	56693	35841	21239	13992	36892	21287	19604	10539	134428	81659	216087	37.8
Somalia	827	324	429	172	290	117	251	106	1797	719	2516	28.6
Benshagul_Gumuz	1322	647	648	287	776	350	565	197	3311	1481	4792	30.9
SNNPR	27424	14077	8508	3971	25170	11787	11273	4639	72375	34474	106849	32.3
Gambella	955	246	580	169	731	244	477	101	2743	760	3503	21.7
Harari	1417	1101	412	340	1493	1381	772	654	4094	3476	7570	45.9
Addis Ababa	23079	24876	16217	16588	28541	30040	17930	16262	85767	87766	173533	50.6
Dire Dawa	1707	1259	683	540	1968	1708	900	767	5258	4274	9532	44.8
Total	166593	121844	73633	53376	123097	87105	67359	43167	430682	305492	736174	41.5

Enrollment by grade 1990 E.C (1997/1998)
Government Secondary Schools

Region	Grade 9		Grade 10		Grade 11		Grade 12		Total		Grand Total	Girls %
	Boys	Girls	Boys	Girls	Boys	Girls	Boys	Girls	Boys	Girls		
Tigray	5480	2777	3466	1615	3011	1377	2003	775	13960	6544	20504	31.9
Afar	361	243	226	127	131	54	68	31	786	455	1241	36.7
Amhara	18239	17519	11758	9514	11753	7557	6709	3783	48459	38373	86832	44.2
Oromiya	33407	23383	21643	12633	19620	8907	10614	4345	85284	49268	134552	36.6
Somalia	379	103	297	76	214	49	141	28	1031	256	1287	19.9
Benshagul_Gumuz	773	375	453	210	393	186	259	93	1878	864	2742	31.5
SNNPR	20682	10202	14123	6391	12187	4815	6158	2172	53150	23580	76730	30.7
Gambella	744	182	505	101	394	94	286	56	1929	433	2362	18.3
Harari	962	922	771	650	919	650	489	332	3141	2554	5695	44.8
Addis Ababa	22157	26910	13580	14108	14343	13660	8600	6979	58680	61657	120337	51.2
Dire Dawa	1185	989	813	644	678	445	348	256	3024	2334	5358	43.6
Total	104369	83605	67635	46069	63643	37794	35675	18850	271322	186318	457640	40.7

Enrollment by grade, 1991 E.C (1998/1999)
Government Secondary Schools

Region	Grade 9		Grade 10		Grade 11		Grade 12		Total		Grand Total	Girls %
	Boys	Girls	Boys	Girls	Boys	Girls	Boys	Girls	Boys	Girls		
Tigray	8167	3877	4304	2194	3054	1511	2386	1054	17911	8636	26547	32.5
Afar	494	341	379	219	127	70	132	56	1132	686	1818	37.7
Amhara	19500	20252	13706	11571	12642	8935	7552	4153	53400	44911	98311	45.7
Oromiya	36004	25254	24709	14451	23100	10412	11990	5188	95803	55305	151108	36.6
Somalia	379	103	297	76	214	49	141	28	1031	256	1287	19.9
Benshagul_Gumuz	949	457	581	300	463	241	309	132	2302	1130	3432	32.9
SNNPR	25231	12453	15521	6845	14372	5326	7510	2583	62634	27207	89841	30.3
Gambella	836	203	644	120	491	114	356	73	2327	510	2837	18.0
Harari	1054	1037	744	547	986	653	561	403	3345	2640	5985	44.1
Addis Ababa	21883	25814	16726	16735	13092	11997	9564	7974	61265	62520	123785	50.5
Dire Dawa	1276	1152	820	602	799	594	404	267	3299	2615	5914	44.2
Total	115773	90943	78431	53660	69340	39902	40905	21911	304449	206416	510865	40.4

Enrollment by grade, 1992 E.C (1999/2000)
Government Secondary Schools

Region	Grade 9		Grade 10		Grade 11		Grade 12		Total		Grand Total	Girls %
	Boys	Girls	Boys	Girls	Boys	Girls	Boys	Girls	Boys	Girls		
Tigray	13659	6603	6642	3270	4297	2267	1757	1440	26355	13580	39935	34.0
Afar	567	379	439	263	353	142	358	113	1717	897	2614	34.3
Amhara	21239	23659	14762	13118	14584	10509	8039	4907	58624	52193	110817	47.1
Oromiya	38220	26152	28683	17178	26571	12816	14798	6847	108272	62993	171265	36.8
Somalia	729	353	353	185	309	114	249	105	1640	757	2397	31.6
Benshagul_Gumuz	1027	560	742	329	567	227	403	157	2739	1273	4012	31.7
SNNPR	20649	11630	18883	8679	15490	6230	8721	3330	63743	29869	93612	31.9
Gambella	788	221	633	130	586	127	442	84	2449	562	3011	18.7
Harari	827	669	874	706	942	702	633	370	3276	2447	5723	42.8
Addis Ababa	17446	19716	17049	17790	15640	14784	9528	7740	59663	60030	119693	50.2
Dire Dawa	1268	790	1123	980	994	669	524	432	3909	2871	6780	42.3
Total	116419	90732	90183	62628	80333	48587	45452	25525	332387	227472	559859	40.6

Enrollment by grade, 1993 E.C (2000/01)
Government Secondary Schools

Region	Grade 9		Grade 10		Grade 11		Grade 12		Total		Grand Total	Girls %
	Boys	Girls	Boys	Girls	Boys	Girls	Boys	Girls	Boys	Girls		
Tigray	23482	16938	10840	5113	7921	3992	3980	1981	46223	28024	74247	37.7
Afar	792	624	406	305	617	383	551	187	2366	1499	3865	38.8
Amhara	28691	25764	13609	11845	18665	15794	11015	7726	71980	61129	133109	45.9
Oromiya	55820	35213	20883	13777	36333	20940	19255	10354	132291	80284	212575	37.8
Somalia	827	324	429	172	290	117	251	106	1797	719	2516	28.6
Benshagul_Gumuz	1322	647	648	287	776	350	565	197	3311	1481	4792	30.9
SNNPR	27187	13926	8413	3909	25013	11672	11195	4602	71808	34109	105917	32.2
Gambella	955	246	580	169	731	244	477	101	2743	760	3503	21.7
Harari	1400	1081	395	328	1472	1372	748	642	4015	3423	7438	46.0
Addis Ababa	21496	23026	15262	15508	27141	28401	15509	14372	79408	81307	160715	50.6
Dire Dawa	1521	1091	586	462	1782	1522	792	657	4681	3732	8413	44.4
Total	163493	118880	72051	51875	120741	84787	64338	40925	420623	296467	717090	41.3

Enrollment by grade 1990 E.C (1997/1998)

Non-Government Secondary Schools

Region	Grade 9		Grade 10		Grade 11		Grade 12		Total		Grand Total	Girls %
	Boys	Girls	Boys	Girls	Boys	Girls	Boys	Girls	Boys	Girls		
Tigray	53	36	31	15	15	12	7	13	106	76	182	41.8
Oromiya	459	277	413	216	369	181	261	124	1502	798	2300	34.7
SNNPR	169	136	118	97	101	64	51	30	439	327	766	42.7
Harari	22	16	16	14					38	30	68	44.1
Addis Ababa	981	1107	818	924	709	779	417	510	2925	3320	6245	53.2
Dire Dawa	86	92	59	54	60	45	42	30	247	221	468	47.2
Total	1770	1664	1455	1320	1254	1081	778	707	5257	4772	10029	47.6

Enrollment by grade, 1991 E.C (1998/1999)

Non-Government Secondary Schools

Region	Grade 9		Grade 10		Grade 11		Grade 12		Total		Grand Total	Girls %
	Boys	Girls	Boys	Girls	Boys	Girls	Boys	Girls	Boys	Girls		
Tigray	41	43	36	28	25	7	11	6	113	84	197	42.6
Amhara	25	52	15	25					40	77	117	65.8
Oromiya	448	315	402	239	399	183	255	132	1504	869	2373	36.6
SNNPR	144	130	104	64	109	57	47	31	404	282	686	41.1
Harari	20	15	20	12	17	11			57	38	95	40.0
Addis Ababa	1065	1220	879	969	815	821	529	617	3288	3627	6915	52.5
Dire Dawa	76	65	76	75	60	44	47	37	259	221	480	46.0
Total	1819	1840	1532	1412	1425	1123	889	823	5665	5198	10863	47.9

Enrollment by grade, 1992 E.C (1999/2000)

Non-Government Secondary Schools

Region	Grade 9		Grade 10		Grade 11		Grade 12		Total		Grand Total	Girls %
	Boys	Girls	Boys	Girls	Boys	Girls	Boys	Girls	Boys	Girls		
Tigray	77	64	51	38	14	2	16		158	104	262	39.7
Amhara	29	50	26	48					55	98	153	64.1
Oromiya	549	380	443	249	427	203	284	132	1703	964	2667	36.1
SNNPR	163	115	114	95	109	67	72	21	458	298	756	39.4
Harari	17	17	20	12	23	12	12	9	72	50	122	41.0
Addis Ababa	1141	1376	951	1115	815	884	537	610	3444	3985	7429	53.6
Dire Dawa	81	68	61	69	69	53	39	31	250	221	471	46.9
Total	2057	2070	1666	1626	1457	1221	960	803	6140	5720	11860	48.2

Enrollment by grade, 1993 E.C (2000/01)

Non-Government Secondary Schools

Region	Grade 9		Grade 10		Grade 11		Grade 12		Total		Grand Total	Girls %
	Boys	Girls	Boys	Girls	Boys	Girls	Boys	Girls	Boys	Girls		
Tigray	167	100	44	41	33	22	41	8	285	171	456	37.5
Amhara	37	47	18	13	0	0	0	0	55	60	115	52.2
Oromiya	873	628	356	215	559	347	349	185	2137	1375	3512	39.2
SNNPR	237	151	95	62	157	115	78	37	567	365	932	39.2
Harari	17	20	17	12	21	9	24	12	79	53	132	40.2
Addis Ababa	1583	1850	955	1080	1400	1639	2421	1890	6359	6459	12818	50.4
Dire Dawa	186	168	97	78	186	186	108	110	577	542	1119	48.4
Total	3100	2964	1582	1501	2356	2318	3021	2242	10059	9025	19084	47.3

National Education budget

(In millions of Birr)

Year E.C.	Description	Expenditure Type	Region											Federal Government	National Total	Year G.C.
			Tigray	Afar	Amhara	Oromiya	Somalia	Benshangul Gumuz	SNNPR	Gambella	Harari	Addis ababa	Dire Dawa			
1990	Education Expenditure	Recurrent	60.84	11.82	211.89	355.96	12.58	5.40	178.03	3.36	11.92	90.01	7.48	173.71	1,123.00	1997/98
		Capital	16.95	8.92	30.31	49.71	25.94	11.06	37.38	9.97	4.20	2.26	0.28	173.50	370.48	
		Total	77.79	20.74	242.20	405.67	38.52	16.46	215.41	13.33	16.12	92.27	7.76	347.21	1,493.48	
	Total Expenditure	Recurrent	205.50	56.99	586.94	914.54	63.89	57.18	480.35	53.18	38.23	341.49	28.43	4,958.30	7,785.02	
		Capital	134.00	102.20	210.96	328.85	173.00	102.21	222.59	40.41	43.43	379.19	17.10	2,511.70	4,265.64	
		Total	339.50	159.19	797.90	1,243.39	236.89	159.39	702.94	93.59	81.66	720.68	45.53	7,470.00	12,050.66	
1991	Education Expenditure	Recurrent	69.69	16.55	230.48	393.07	13.12	12.09	205.22	4.34	12.65	97.32	8.55	175.53	1,238.61	1998/99
		Capital	33.40	35.32	65.98	111.23	54.05	25.31	85.71	29.04	6.99	83.83	5.87	287.30	824.03	
		Total	103.09	51.87	296.46	504.30	67.17	37.40	290.93	33.38	19.64	181.15	14.42	462.83	2,062.64	
	Total Expenditure	Recurrent	216.00	101.12	673.85	1,005.61	100.00	78.00	541.80	64.80	43.82	408.25	34.44	7,110.30	10,377.99	
		Capital	229.20	192.34	441.66	546.42	341.38	133.88	382.64	98.40	59.75	753.66	30.51	3,252.40	6,462.24	
		Total	445.20	293.46	1,115.51	1,552.03	441.38	211.88	924.44	163.20	103.57	1,161.91	64.95	10,362.70	16,840.23	
1992	Education Budget	Recurrent	72.73	14.25	234.06	414.23	17.23	17.32	211.67	4.72	13.71	107.91	8.65	277.00	1,393.48	1999/2000
		Capital	41.57	39.75	73.53	71.48	30.74	11.44	56.15	13.61	5.08	39.09	2.72	525.20	910.36	
		Total	114.30	54.00	307.59	485.71	47.97	28.76	267.82	18.33	18.79	147.00	11.37	802.20	2,303.84	
	Total Budget	Recurrent	210.00	85.00	597.48	975.75	112.00	79.20	543.77	66.60	43.54	614.35	34.30	11,049.90	14,411.89	
		Capital	102.00	168.65	336.39	300.70	203.60	67.43	209.77	49.00	31.14	548.29	12.45	3,984.90	6,014.32	
		Total	312.00	253.65	933.87	1,276.45	315.60	146.63	753.54	115.60	74.68	1,162.64	46.75	15,034.80	20,426.21	
1993	Education Budget	Recurrent	81.79	22.35	259.52	459.67	22.72	19.19	236.82	4.75	15.92	135.81	11.65	314.46	1,584.65	2000/2001
		Capital	84.23	25.57	108.69	132.65	41.64	21.19	112.29	19.14	8.71	154.53	7.26	184.56	900.46	
		Total	166.02	47.92	368.21	592.32	64.36	40.38	349.11	23.89	24.63	290.34	18.91	499.02	2,485.11	
	Total Budget	Recurrent	234.28	110.33	666.94	1,158.30	135.57	91.56	599.95	71.94	46.00	555.33	43.46	8,583.80	12,297.46	
		Capital	247.94	143.31	470.67	612.07	249.51	101.27	389.08	73.24	29.45	772.42	22.71	2,658.28	5,769.95	
		Total	482.22	253.64	1,137.61	1,770.37	385.08	192.83	989.03	145.18	75.45	1,327.75	66.17	11,242.08	18,067.41	
1994	Education Budget	Recurrent	96.80	24.90	280.44	560.62	26.13	22.13	245.21	6.06	16.10	158.53	14.38	378.92	1,830.22	2001/2002
		Capital *														
		Total	96.80	24.90	280.44	560.62	26.13	22.13	245.21	6.06	16.10	158.53	14.38	378.92	1,830.22	
	Total Budget	Recurrent	265.54	135.72	734.89	1,321.54	178.00	107.02	607.66	81.45	47.00	615.24	56.47	7,239.40	11,389.93	
		Capital *														
		Total	265.54	135.72	734.89	1,321.54	178.00	107.02	607.66	81.45	47.00	615.24	56.47	7,239.40	11,389.93	

Source: Ministry of Finance & Economy development

* data not available

Enrollment in Kindergarten 1994 E.C.

Regions	School Age Population (4-6)			Pupils (Enrollment)			Gross Enrollment ratio			Teachers						Grand Total	Pupil Teacher Ratio	No. of Kindergarten
	Boys	Girls	Total	Boys	Girls	Total	Boys	Girls	Total	Trained		Untrained		Total				
										Male	Female	Male	Female	Male	Female			
Tigray	175091	170483	345575	3504	3621	7125	2.0	2.1	2.1	95		46		141	141	51	75	
Afar*	53620	45048	98668	308	281	589	0.6	0.6	0.6	2	4	4	4	6	10	59	6	
Amhara	755039	745700	1500739	9377	8942	18319	1.2	1.2	1.2	6	194	11	138	17	332	349	52	339
Oromiya	1070532	1056990	2127521	15800	14865	30665	1.5	1.4	1.4	84	446	21	271	105	717	822	37	298
Somalia	170526	152619	323145	1082	1044	2126	0.6	0.7	0.7	31	13			31	13	44	48	11
Benshangul-Gumuz	25344	24302	49645	477	462	939	1.9	1.9	1.9	5		7		12	12	78	8	
SNNPR	603044	595238	1198282	9201	8516	17717	1.5	1.4	1.5	32	252	73	175	105	427	532	33	135
Gambella	8611	8106	16718	99	92	191	1.1	1.1	1.1	3	3			3	3	6	32	2
Harari	5765	5414	11179	484	473	957	8.4	8.7	8.6					10	37	47	20	9
Addis Abeba	54793	49870	104663	19272	18783	38055	35.2	37.7	36.4	26	1090	44	544	70	1634	1704	22	292
Dire Dawa	11968	11077	23045	1205	1098	2303	10.1	9.9	10.0	1	39	2	14	3	53	56	41	14
Total	2934334	2864847	5799181	60809	58177	118986	2.1	2.0	2.1	188	2134	162	1192	350	3326	3676	32	1189

* 1993 E.C. Data

Enrollment in Primary School Regular

Government and Non-Government School - 1994 E.C.

Region	Grade 1		Grade 2		Grade 3		Grade 4		Grade 5		Grade 6		Grade 7		Grade 8		Total		
	Male	Female	Male	Female	Male	Female	Male	Female	Male	Female	Male	Female	Male	Female	Male	Female	Male	Female	Both
Tigray	66303	65022	55711	57093	45142	43901	36881	35420	32907	29014	24737	19937	23573	19915	19303	14082	304557	284384	588941
Afar	6799	3981	3183	1628	2451	1314	1634	962	1213	873	1041	722	1292	820	796	415	18409	10715	29124
Amhara	257725	241592	194801	180423	167364	149214	135424	110476	109445	81468	80935	53399	68011	45282	42057	30432	1055762	892286	1948048
Oromia	433323	307396	333237	220000	291086	174239	258517	144178	195992	90728	146292	60059	123359	52807	78430	37147	1860236	1086554	2946790
Somale	22121	11853	17267	8252	10574	5107	7386	3597	4925	2315	3924	1798	3053	1233	2318	849	71568	35004	106572
Benishangul-Gumuz	16681	11439	10563	7006	9650	5477	8188	4543	7268	3522	5085	2061	5006	2084	2534	902	64975	37034	102009
SNNPR	311387	223352	178129	117851	152725	92200	133252	73063	110229	54776	86424	39137	88549	40040	48063	21242	1108758	661661	1770419
Gambella	6510	4428	4003	2408	3684	1992	3270	2014	3047	1781	2165	985	1757	547	1532	374	25968	14529	40497
Harari	3148	2478	2093	1668	2063	1468	2093	1445	1909	1177	1758	939	1764	1034	1300	934	16128	11143	27271
Addis Ababa	23632	26993	22391	25253	20813	23502	23293	25016	23047	25769	21536	24056	24958	28995	20574	25265	180244	204849	385093
Dire Dawa	3996	2976	3266	2236	2705	1965	2881	2188	2679	1974	2190	1593	1934	1441	2194	1778	21845	16151	37996
Total	1151625	901510	824644	623818	708257	500379	612819	402902	492661	293397	376087	204686	343256	194198	219101	133420	4728450	3254310	7982760

Enrollment in Primary School Regular

Government - 1994 E.C.

Region	Grade 1		Grade 2		Grade 3		Grade 4		Grade 5		Grade 6		Grade 7		Grade 8		Total		
	Male	Female	Male	Female	Male	Female	Male	Female	Male	Female	Male	Female	Male	Female	Male	Female	Male	Female	Both
Tigray	64986	63649	54563	55955	44286	43025	36235	34782	32428	28586	24367	19491	23198	19517	18963	13671	299026	278676	577702
Afar	6527	3851	3059	1606	2407	1303	1616	953	1206	871	1037	720	1292	820	796	415	17940	10539	28479
Amhara	256099	239821	193647	179176	166352	148305	134553	109665	108679	80776	80340	52809	67321	44746	41533	29970	1048524	885268	1933792
Oromia	420139	298045	323331	213656	283620	169407	252626	140046	191425	87544	142644	57745	120841	50825	76281	35208	1810907	1052476	2863383
Somale	21599	11388	17032	7989	10347	4916	7208	3398	4835	2228	3882	1760	3015	1192	2288	817	70206	33688	103894
Benishangul-Gumuz	16484	11315	10420	6909	9531	5426	8117	4516	7268	3522	5085	2061	5006	2084	2534	902	64445	36735	101180
SNNPR	299752	215403	171274	113508	146829	88593	128155	70060	106400	52654	83271	37354	86524	38922	46695	20442	1068900	636936	1705836
Gambella	6419	4377	3987	2402	3684	1992	3270	2014	3047	1781	2165	985	1757	547	1532	374	25861	14472	40333
Harari	2965	2252	1974	1572	1944	1361	1996	1347	1820	1088	1649	860	1670	945	1236	871	15254	10296	25550
Addis Ababa	10766	13542	11193	13743	10099	12361	12153	13576	12448	14419	11219	13100	14102	16638	10371	12476	92351	109855	202206
Dire Dawa	3371	2432	2688	1737	2263	1540	2450	1759	2283	1622	1813	1265	1497	1108	1825	1437	18190	12900	31090
Total	1109107	866075	793168	598253	681362	478229	588379	382116	471839	275091	357472	188150	326223	177344	204054	116583	4531604	3081841	7613445

Non-Government - 1994 E.C.

Region	Grade 1		Grade 2		Grade 3		Grade 4		Grade 5		Grade 6		Grade 7		Grade 8		Total		
	Male	Female	Male	Female	Male	Female	Male	Female	Male	Female	Male	Female	Male	Female	Male	Female	Male	Female	Both
Tigray	1317	1373	1148	1138	856	876	646	638	479	428	370	446	375	398	340	411	5531	5708	11239
Afar	272	130	124	22	44	11	18	9	7	2	4	2					469	176	645
Amhara	1626	1771	1154	1247	1012	909	871	811	766	692	595	590	690	536	524	462	7238	7018	14256
Oromia	13184	9351	9906	6344	7466	4832	5891	4132	4567	3184	3648	2314	2518	1982	2149	1939	49329	34078	83407
Somale	522	465	235	263	227	191	178	199	90	87	42	38	38	41	30	32	1362	1316	2678
Benishangul-Gumuz	197	124	143	97	119	51	71	27									530	299	829
SNNPR	11635	7949	6855	4343	5896	3607	5097	3003	3829	2122	3153	1783	2025	1118	1368	800	39858	24725	64583
Gambella	91	51	16	6													107	57	164
Harari	183	226	119	96	119	107	97	98	89	89	109	79	94	89	64	63	874	847	1721
Addis Ababa	12866	13451	11198	11510	10714	11141	11140	11440	10599	11350	10317	10956	10856	12357	10203	12789	87893	94994	182887
Dire Dawa	625	544	578	499	442	425	431	429	396	352	377	328	437	333	369	341	3655	3251	6906
Total	42518	35435	31476	25565	26895	22150	24440	20786	20822	18306	18615	16536	17033	16854	15047	16837	196846	172469	369315

Enrollment in Primary School

Regular

Urban - 1994 E.C.

Region	Grade 1		Grade 2		Grade 3		Grade 4		Grade 5		Grade 6		Grade 7		Grade 8		Total		
	Male	Female	Male	Female	Male	Female	Male	Female	Male	Female	Male	Female	Male	Female	Male	Female	Male	Female	Both
Tigray	17101	16893	13597	14008	12018	12531	10494	11184	10850	10871	9352	9132	13018	12714	10945	9219	97375	96552	193927
Afar	2491	1901	1237	956	1116	936	946	741	829	719	762	576	1044	711	598	397	9023	6937	15960
Amhara	38344	38342	28653	28721	26711	26788	23616	23808	29919	28114	24008	21203	40196	30942	26751	22073	238198	219991	458189
Oromia	80469	72615	64272	56099	60828	50975	64236	52418	67328	43558	55740	32101	71671	37260	49775	28195	514319	373221	887540
Somale	10654	5404	8584	4185	6244	2998	4506	2254	3542	1781	3116	1391	2660	1067	2168	812	41474	19892	61366
Benishangul-Gumuz	2439	2145	1613	1487	1519	1331	1548	1283	2227	1329	1790	884	2553	1324	1405	631	15094	10414	25508
SNNPR	41425	35496	24067	20463	22985	18758	21154	16489	21699	15334	18937	12367	44323	23207	26396	13498	220986	155612	376598
Gambella	1213	963	676	577	624	490	776	707	1014	819	768	505	810	388	757	285	6638	4734	11372
Harari	1359	1426	1076	1042	979	918	1026	981	1077	966	1089	856	1482	1014	1164	917	9252	8120	17372
Addis Ababa	23512	26857	22209	25059	20721	23337	23195	24891	23047	25769	21536	24056	24958	28995	20574	25265	179752	204229	383981
Dire Dawa	2157	2087	2101	1802	1818	1704	2140	2000	2134	1887	1857	1549	1761	1430	2137	1769	16105	14228	30333
Total	221164	204129	168085	154399	155563	140766	153637	136756	163666	131147	138955	104620	204476	139052	142670	103061	1348216	1113930	2462146

Rural - 1994 E.C.

Region	Grade 1		Grade 2		Grade 3		Grade 4		Grade 5		Grade 6		Grade 7		Grade 8		Total		
	Male	Female	Male	Female	Male	Female	Male	Female	Male	Female	Male	Female	Male	Female	Male	Female	Male	Female	Both
Tigray	49202	48129	42114	43085	33124	31370	26387	24236	22057	18143	15385	10805	10555	7201	8358	4863	207182	187832	395014
Afar	4308	2080	1946	672	1335	378	688	221	384	154	279	146	248	109	198	18	9386	3778	13164
Amhara	219381	203250	166148	151702	140653	122426	111808	86668	79526	53354	56927	32196	27815	14340	15306	8359	817564	672295	1489859
Oromia	352854	234781	268965	163901	230258	123264	194281	91760	128664	47170	90552	27958	51688	15547	28655	8952	1345917	713333	2059250
Somale	11467	6449	8683	4067	4330	2109	2880	1343	1383	534	808	407	393	166	150	37	30094	15112	45206
Benishangul-Gumuz	14242	9294	8950	5519	8131	4146	6640	3260	5041	2193	3295	1177	2453	760	1129	271	49881	26620	76501
SNNPR	269962	187856	154062	97388	129740	73442	112098	56574	88530	39442	67487	26770	44226	16833	21667	7744	887772	506049	1393821
Gambella	5297	3465	3327	1831	3060	1502	2494	1307	2033	962	1397	480	947	159	775	89	19330	9795	29125
Harari	1789	1052	1017	626	1084	550	1067	464	832	211	669	83	282	20	136	17	6876	3023	9899
Addis Ababa	120	136	182	194	92	165	98	125									492	620	1112
Dire Dawa	1839	889	1165	434	887	261	741	188	545	87	333	44	173	11	57	9	5740	1923	7663
Total	930461	697381	656559	469419	552694	359613	459182	266146	328995	162250	237132	100066	138780	55146	76431	30359	3380234	2140380	5520614

Enrollment in Secondary School Regular

Government and Non-Government School - 1994 E.C.

Region	Grade 9		Grade 10		Grade 11		Grade 12		Total		
	Male	Female	Male	Female	Male	Female	Male	Female	Male	Female	Both
Tigray	16664	9407	18969	11633	3620	939	7815	3233	47068	25212	72280
Afar	1043	651	345	180	95	34	694	413	2177	1278	3455
Amhara	32648	22842	16385	10455	5995	2630	16760	12271	71788	48198	119986
Oromia	74340	38404	30012	17403	6559	2660	36349	19547	147260	78014	225274
Somale	2265	675	1098	345	63	13	586	208	4012	1241	5253
Benishangul-Gumuz	1905	849	1007	410	219	36	1007	544	4138	1839	5977
SNNPR	39524	17598	11695	5476	1692	515	26567	11460	79478	35049	114527
Gambella	808	211	391	76	56	4	406	117	1661	408	2069
Harari	1501	1008	821	564	156	58	1342	952	3820	2582	6402
Addis Ababa	22099	24802	13731	13648	4139	3310	20609	20083	60578	61843	122421
Dire Dawa	1612	1202	889	555	108	52	1475	1093	4084	2902	6986
Total	194409	117649	95343	60745	22702	10251	113610	69921	426064	258566	684630

Government School - 1994 E.C.

Region	Grade 9		Grade 10		Grade 11		Grade 12		Total		
	Male	Female	Male	Female	Male	Female	Male	Female	Male	Female	Both
Tigray	16354	9102	18715	11429	3470	852	7724	3213	46263	24596	70859
Afar	1043	651	345	180	95	34	694	413	2177	1278	3455
Amhara	32560	22743	16346	10419	5995	2630	16760	12271	71661	48063	119724
Oromia	73401	37782	29530	17136	6322	2583	35930	19315	145183	76816	221999
Somale	2265	675	1098	345	63	13	586	208	4012	1241	5253
Benishangul-Gumuz	1905	849	1007	410	219	36	1007	544	4138	1839	5977
SNNPR	39292	17456	11565	5391	1692	515	26418	11348	78967	34710	113677
Gambella	808	211	391	76	56	4	406	117	1661	408	2069
Harari	1488	982	809	548	156	58	1322	942	3775	2530	6305
Addis Ababa	20291	22664	12775	12360	3704	2755	19661	18991	56431	56770	113201
Dire Dawa	1485	1104	791	475	108	52	1405	1024	3789	2655	6444
Total	190892	114219	93372	58769	21880	9532	111913	68386	418057	250906	668963

Non-Government School - 1994 E.C.

Region	Grade 9		Grade 10		Grade 11		Grade 12		Total		
	Male	Female	Male	Female	Male	Female	Male	Female	Male	Female	Both
Tigray	310	305	254	204	150	87	91	20	805	616	1421
Afar											
Amhara	88	99	39	36					127	135	262
Oromia	939	622	482	267	237	77	419	232	2077	1198	3275
Somale											
Benishangul-Gumuz											
SNNPR	232	142	130	85			149	112	511	339	850
Gambella											
Harari	13	26	12	16			20	10	45	52	97
Addis Ababa	1808	2138	956	1288	435	555	948	1092	4147	5073	9220
Dire Dawa	127	98	98	80			70	69	295	247	542
Total	3517	3430	1971	1976	822	719	1697	1535	8007	7660	15667

Enrollment in Secondary School Regular

Urban School - 1994 E.C.

Region	Grade 9		Grade 10		Grade 11		Grade 12		Total		
	Male	Female	Male	Female	Male	Female	Male	Female	Male	Female	Both
Tigray	15936	8942	18528	11374	3620	939	7815	3233	45899	24488	70387
Afar	823	518	282	150	61	25	546	349	1712	1042	2754
Amhara	31577	22282	15951	10249	5995	2624	16572	12176	70095	47331	117426
Oromia	73055	37333	29278	16546	6531	2621	34930	18261	143794	74761	218555
Somale	2265	675	1098	345	63	13	586	208	4012	1241	5253
Benishangul-Gumuz	1766	793	931	382	219	36	1007	544	3923	1755	5678
SNNPR	37274	16970	11121	5262	1606	500	25614	11199	75615	33931	109546
Gambella	684	204	335	74	56	4	406	117	1481	399	1880
Harari	1501	1008	821	564	156	58	1342	952	3820	2582	6402
Addis Ababa	22099	24802	13731	13648	4139	3310	20609	20083	60578	61843	122421
Dire Dawa	1612	1202	889	555	108	52	1475	1093	4084	2902	6986
Total	188592	114729	92965	59149	22554	10182	110902	68215	415013	252275	667288

Rural School - 1994 E.C.

Region	Grade 9		Grade 10		Grade 11		Grade 12		Total		
	Male	Female	Male	Female	Male	Female	Male	Female	Male	Female	Both
Tigray	728	465	441	259					1169	724	1893
Afar	220	133	63	30	34	9	148	64	465	236	701
Amhara	1071	560	434	206		6	188	95	1693	867	2560
Oromia	1285	1071	734	857	28	39	1419	1286	3466	3253	6719
Somale											
Benishangul-Gumuz	139	56	76	28					215	84	299
SNNPR	2250	628	574	214	86	15	953	261	3863	1118	4981
Gambella	124	7	56	2					180	9	189
Harari											
Addis Ababa											
Dire Dawa											
Total	5817	2920	2378	1596	148	69	2708	1706	11051	6291	17342

Enrollment in Primary School Evening

Government and Non-Government School - 1994 E.C.

Region	Grade 1		Grade 2		Grade 3		Grade 4		Grade 5		Grade 6		Grade 7		Grade 8		Total		
	Male	Female	Male	Female	Male	Female	Male	Female	Male	Female	Male	Female	Male	Female	Male	Female	Male	Female	Both
Tigray	1053	1078	913	630	879	610	866	582	874	629	943	666	1205	825	2618	2890	9351	7910	17261
Afar	110	51	198	123	160	89	126	75	114	67	114	53	105	101	63	62	990	621	1611
Amhara	865	899	1210	1011	1788	1292	1147	986	796	737	722	669	958	927	967	1079	8453	7600	16053
Oromia	1569	1480	2204	1700	1923	1368	1689	943	1619	757	1490	710	1772	905	1812	1235	14078	9098	23176
Somale																			
Benishangul-Gumuz	10	2	1	2													11	4	15
SNNPR	917	996	1109	899	959	759	900	663	1012	575	914	545	1283	734	1028	698	8122	5869	13991
Gambella					97	122	91	79	72	78	62	66	80	79	108	108	510	532	1042
Harari	12	18	45	35	146	173	68	57	74	61	85	57	86	66	152	66	668	533	1201
Addis Ababa	3549	5283	7140	8715	5962	6167	5168	5244	4686	4161	4362	3570	4517	3564	5287	4696	40671	41400	82071
Dire Dawa	169	236	471	604	378	418	314	268	285	242	280	228	288	205	366	404	2551	2605	5156
Total	8254	10043	13291	13719	12292	10998	10369	8897	9532	7307	8972	6564	10294	7406	12401	11238	85405	76172	161577

Enrollment in Primary School Evening

Government - 1994 E.C.

Region	Grade 1		Grade 2		Grade 3		Grade 4		Grade 5		Grade 6		Grade 7		Grade 8		Total		
	Male	Female	Male	Female	Male	Female	Male	Female	Male	Female	Male	Female	Male	Female	Male	Female	Male	Female	Both
Tigray	1017	1036	851	601	829	580	808	547	821	591	884	634	1136	786	2496	2682	8842	7457	16299
Afar	110	51	198	123	160	89	126	75	114	67	114	53	105	101	63	62	990	621	1611
Amhara	803	894	1186	1008	1764	1292	1147	986	796	737	722	669	958	927	967	1079	8343	7592	15935
Oromia	1084	961	1697	1289	1494	1010	1297	678	1224	532	1131	518	1423	684	1397	784	10747	6456	17203
Somale																			
Benishangul-Gumuz	10	2	1	2													11	4	15
SNNPR	830	927	1031	839	843	664	794	580	909	496	828	476	1217	678	938	629	7390	5289	12679
Gambella					97	122	91	79	72	78	62	66	80	79	108	108	510	532	1042
Harari	12	18	45	35	53	85	47	43	49	51	69	49	70	51	136	50	481	382	863
Addis Ababa	1251	1681	3094	3487	2454	2357	2119	1928	1805	1510	1629	1294	1754	1303	2137	1845	16243	15405	31648
Dire Dawa	169	236	468	577	323	373	263	236	219	215	227	195	222	165	212	231	2103	2228	4331
Total	5286	5806	8571	7961	8017	6572	6692	5152	6009	4277	5666	3954	6965	4774	8454	7470	55660	45966	101626

Non-Government - 1994 E.C.

Region	Grade 1		Grade 2		Grade 3		Grade 4		Grade 5		Grade 6		Grade 7		Grade 8		Total		
	Male	Female	Male	Female	Male	Female	Male	Female	Male	Female	Male	Female	Male	Female	Male	Female	Male	Female	Both
Tigray	36	42	62	29	50	30	58	35	53	38	59	32	69	39	122	208	509	453	962
Afar																			
Amhara	62	5	24	3	24												110	8	118
Oromia	485	519	507	411	429	358	392	265	395	225	359	192	349	221	415	451	3331	2642	5973
Somale																			
Benishangul-Gumuz																			
SNNPR	87	69	78	60	116	95	106	83	103	79	86	69	66	56	90	69	732	580	1312
Gambella																			
Harari					93	88	21	14	25	10	16	8	16	15	16	16	187	151	338
Addis Ababa	2298	3602	4046	5228	3508	3810	3049	3316	2881	2651	2733	2276	2763	2261	3150	2851	24428	25995	50423
Dire Dawa			3	27	55	45	51	32	66	27	53	33	66	40	154	173	448	377	825
Total	2968	4237	4720	5758	4275	4426	3677	3745	3523	3030	3306	2610	3329	2632	3947	3768	29745	30206	59951

Enrollment in Primary School
Evening

Urban - 1994 E.C.

Region	Grade 1		Grade 2		Grade 3		Grade 4		Grade 5		Grade 6		Grade 7		Grade 8		Total		
	Male	Female	Male	Female	Male	Female	Male	Female	Male	Female	Male	Female	Male	Female	Male	Female	Male	Female	Both
Tigray	940	986	912	630	865	606	852	579	863	627	920	659	1158	818	2526	2847	9036	7752	16788
Afar	42	13	140	91	116	73	98	62	97	60	84	43	88	86	52	52	717	480	1197
Amhara	324	291	809	566	1401	976	920	670	640	617	609	631	868	914	879	1063	6450	5728	12178
Oromia	1458	1445	1933	1495	1763	1308	1456	891	1387	708	1288	645	1452	861	1487	1167	12224	8520	20744
Somale																			
Benishangul-Gumuz																			
SNNPR	530	679	724	659	636	550	627	466	633	392	592	380	774	551	858	623	5374	4300	9674
Gambella					97	122	91	79	72	78	62	66	80	79	108	108	510	532	1042
Harari	12	18	45	35	146	173	68	57	74	61	85	57	86	66	152	66	668	533	1201
Addis Ababa	3549	5283	7140	8715	5962	6167	5168	5244	4686	4161	4362	3570	4517	3564	5287	4696	40671	41400	82071
Dire Dawa	169	236	471	604	378	418	314	268	285	242	280	228	288	205	366	404	2551	2605	5156
Total	7024	8951	12174	12795	11364	10393	9594	8316	8737	6946	8282	6279	9311	7144	11715	11026	78201	71850	150051

Rural - 1994 E.C.

Region	Grade 1		Grade 2		Grade 3		Grade 4		Grade 5		Grade 6		Grade 7		Grade 8		Total		
	Male	Female	Male	Female	Male	Female	Male	Female	Male	Female	Male	Female	Male	Female	Male	Female	Male	Female	Both
Tigray	113	92	1		14	4	14	3	11	2	23	7	47	7	92	43	315	158	473
Afar	68	38	58	32	44	16	28	13	17	7	30	10	17	15	11	10	273	141	414
Amhara	541	608	401	445	387	316	227	316	156	120	113	38	90	13	88	16	2003	1872	3875
Oromia	111	35	271	205	160	60	233	52	232	49	202	65	320	44	325	68	1854	578	2432
Somale																			
Benishangul-Gumuz	10	2	1	2													11	4	15
SNNPR	387	317	385	240	323	209	273	197	379	183	322	165	509	183	170	75	2748	1569	4317
Gambella																			
Harari																			
Addis Ababa																			
Dire Dawa																			
Total	1230	1092	1117	924	928	605	775	581	795	361	690	285	983	262	686	212	7204	4322	11526

Enrollment in Secondary School Evening

Government and Non-Government School - 1994 E.C.

Region	Grade 9		Grade 10		Grade 11		Grade 12		Total		
	Male	Female	Male	Female	Male	Female	Male	Female	Male	Female	Both
Tigray	2951	3091	1550	1425			577	614	5078	5130	10208
Afar	40	95	41	71			29	36	110	202	312
Amhara	2021	2896	712	1275	134	413	1602	2751	4469	7335	11804
Oromia	2447	2552	765	927	477	622	2259	2499	5948	6600	12548
Somale											
Benishangul-Gumuz											
SNNPR	960	981	393	463	207	212	1518	1674	2903	3127	6030
Gambella	60	54	30	22			116	95	206	171	377
Harari	180	171	62	82			267	394	509	647	1156
Addis Ababa	6020	5352	2814	3032	688	682	8590	8502	18112	17568	35680
Dire Dawa	243	213	81	109	298	315	135	124	757	761	1518
Total	14922	15405	6448	7406	1804	2244	15093	16689	38092	41541	79633

Government School - 1994 E.C.

Region	Grade 9		Grade 10		Grade 11		Grade 12		Total		
	Male	Female	Male	Female	Male	Female	Male	Female	Male	Female	Both
Tigray	2951	3091	1550	1425			577	614	5078	5130	10208
Afar	40	95	41	71			29	36	110	202	312
Amhara	2021	2896	712	1275	134	413	1602	2751	4469	7335	11804
Oromia	2357	2435	748	901	477	622	2167	2374	5749	6332	12081
Somale											
Benishangul-Gumuz											
SNNPR	960	981	393	463	207	212	1518	1674	2903	3127	6030
Gambella	60	54	30	22			116	95	206	171	377
Harari	180	171	62	82			267	394	509	647	1156
Addis Ababa	5592	5028	2612	2859	688	682	8140	8351	17032	16920	33952
Dire Dawa	141	138	50	76	298	315			489	529	1018
Total	14302	14889	6198	7174	1804	2244	14416	16289	36545	40393	76938

Non-Government School - 1994 E.C.

Region	Grade 9		Grade 10		Grade 11		Grade 12		Total		
	Male	Female	Male	Female	Male	Female	Male	Female	Male	Female	Both
Tigray											
Afar											
Amhara											
Oromia	90	117	17	26			92	125	199	268	467
Somale											
Benishangul-Gumuz											
SNNPR											
Gambella											
Harari											
Addis Ababa	428	324	202	173			450	151	1080	648	1728
Dire Dawa	102	75	31	33			135	124	268	232	500
Total	620	516	250	232			677	400	1547	1148	2695

Enrollment in Secondary School Evening

Urban School - 1994 E.C.

Region	Grade 9		Grade 10		Grade 11		Grade 12		Total		
	Male	Female	Male	Female	Male	Female	Male	Female	Male	Female	Both
Tigray	2892	3067	1522	1404			577	614	4991	5085	10076
Afar	40	95	41	71			29	36	110	202	312
Amhara	2021	2896	712	1275	134	413	1602	2751	4469	7335	11804
Oromia	2310	2480	717	894	477	622	2172	2449	5676	6445	12121
Somale											
Benishangul-Gumuz											
SNNPR	947	976	383	461	207	212	1511	1673	2873	3119	5992
Gambella	60	54	30	22			116	95	206	171	377
Harari	180	171	62	82			267	394	509	647	1156
Addis Ababa	6020	5352	2814	3032	688	682	8590	8502	18112	17568	35680
Dire Dawa	243	213	81	109	298	315	135	124	757	761	1518
Total	14713	15304	6362	7350	1804	2244	14999	16638	37703	41333	79036

Rural School - 1994 E.C.

Region	Grade 9		Grade 10		Grade 11		Grade 12		Total		
	Male	Female	Male	Female	Male	Female	Male	Female	Male	Female	Both
Tigray	59	24	28	21					87	45	132
Afar											
Amhara											
Oromia	137	72	48	33			87	50	272	155	427
Somale											
Benishangul-Gumuz											
SNNPR	13	5	10	2			7	1	30	8	38
Gambella											
Harari											
Addis Ababa											
Dire Dawa											
Total	209	101	86	56			94	51	389	208	597

Repeaters in Primary School Regular

Government and Non-Government School - 1994 E.C.

Region	Grade 1		Grade 2		Grade 3		Grade 4		Grade 5		Grade 6		Grade 7		Grade 8		Total		
	Male	Female	Male	Female	Male	Female	Male	Female	Male	Female	Male	Female	Male	Female	Male	Female	Male	Female	Both
Tigray	4813	5844	2313	2862	1516	1982	2848	4089	1319	2169	748	979	1128	1995	381	654	15066	20574	35640
Afar	1245	873	425	318	152	114	154	105	75	100	31	47	277	271	108	77	2467	1905	4372
Amhara	46501	51598	23788	27694	16169	17442	9577	10268	8691	11034	3313	3855	4868	6830	5341	6625	118248	135346	253594
Oromia	18902	13558	12228	8586	9162	6553	14842	11578	7978	5852	3199	2169	7944	7119	5258	5373	79513	60788	140301
Somale	710	341	358	254	336	253	258	159	190	112	80	65	48	55	119	86	2099	1325	3424
Benishangul-Gumuz	1992	1623	1189	956	1091	780	1020	683	897	566	310	193	1145	704	468	210	8112	5715	13827
SNNPR	44623	32382	15374	11571	13078	9912	12127	8881	8224	6094	5262	3553	12370	8728	9020	5591	120078	86712	206790
Gambella	518	457	109	112	142	157	314	333	523	445	271	183	251	83	300	87	2428	1857	4285
Harari	324	276	140	119	131	79	149	98	184	125	84	70	264	226	226	278	1502	1271	2773
Addis Ababa	217	164	136	94	155	116	2303	2049	2809	2910	1732	1927	4662	6095	3415	5681	15429	19036	34465
Dire Dawa	70	47	68	36	46	40	221	160	97	65	42	41	179	221	353	438	1076	1048	2124
Total	119915	107163	56128	52602	41978	37428	43813	38403	30987	29472	15072	13082	33136	32327	24989	25100	366018	335577	701595

Repeaters in Primary School Regular

Government - 1994 E.C.

Region	Grade 1		Grade 2		Grade 3		Grade 4		Grade 5		Grade 6		Grade 7		Grade 8		Total		
	Male	Female	Male	Female	Male	Female	Male	Female	Male	Female	Male	Female	Male	Female	Male	Female	Male	Female	Both
Tigray	4670	5671	2268	2824	1498	1960	2830	4055	1311	2158	743	973	1114	1980	381	652	14815	20273	35088
Afar	1219	853	418	312	152	114	152	104	75	100	31	47	277	271	108	77	2432	1878	4310
Amhara	46317	51301	23714	27561	16115	17367	9511	10203	8653	10970	3288	3823	4818	6755	5287	6577	117703	134557	252260
Oromia	17894	12905	11707	8255	8841	6296	14632	11351	7764	5649	3108	2085	7754	6854	5101	5107	76801	58502	135303
Somale	706	336	349	245	334	250	252	150	180	103	79	63	43	38	119	86	2062	1271	3333
Benishangul-Gumuz	1953	1589	1162	934	1063	764	1003	672	897	566	310	193	1145	704	468	210	8001	5632	13633
SNNPR	43260	31332	14814	11139	12653	9517	11801	8582	8030	5895	5129	3427	12162	8563	8845	5481	116694	83936	200630
Gambella	518	457	109	112	142	157	314	333	523	445	271	183	251	83	300	87	2428	1857	4285
Harari	317	265	133	112	124	77	143	93	177	118	79	66	257	220	226	278	1456	1229	2685
Addis Ababa	47	59	19	10	38	18	1505	1306	1939	1997	1242	1346	3312	4422	2050	3382	10152	12540	22692
Dire Dawa	42	34	51	18	35	34	185	135	67	37	28	27	135	163	328	419	871	867	1738
Total	116943	104802	54744	51522	40995	36554	42328	36984	29616	28038	14308	12233	31268	30053	23213	22356	353415	322542	675957

Non-Government - 1994 E.C.

Region	Grade 1		Grade 2		Grade 3		Grade 4		Grade 5		Grade 6		Grade 7		Grade 8		Total		
	Male	Female	Male	Female	Male	Female	Male	Female	Male	Female	Male	Female	Male	Female	Male	Female	Male	Female	Both
Tigray	143	173	45	38	18	22	18	34	8	11	5	6	14	15		2	251	301	552
Afar	26	20	7	6			2	1									35	27	62
Amhara	184	297	74	133	54	75	66	65	38	64	25	32	50	75	54	48	545	789	1334
Oromia	1008	653	521	331	321	257	210	227	214	203	91	84	190	265	157	266	2712	2286	4998
Somale	4	5	9	9	2	3	6	9	10	9	1	2	5	17			37	54	91
Benishangul-Gumuz	39	34	27	22	28	16	17	11									111	83	194
SNNPR	1363	1050	560	432	425	395	326	299	194	199	133	126	208	165	175	110	3384	2776	6160
Gambella																			
Harari	7	11	7	7	7	2	6	5	7	7	5	4	7	6			46	42	88
Addis Ababa	170	105	117	84	117	98	798	743	870	913	490	581	1350	1673	1365	2299	5277	6496	11773
Dire Dawa	28	13	17	18	11	6	36	25	30	28	14	14	44	58	25	19	205	181	386
Total	2972	2361	1384	1080	983	874	1485	1419	1371	1434	764	849	1868	2274	1776	2744	12603	13035	25638

Repeaters in Primary School

Regular

Urban - 1994 E.C.

Region	Grade 1		Grade 2		Grade 3		Grade 4		Grade 5		Grade 6		Grade 7		Grade 8		Total		
	Male	Female	Male	Female	Male	Female	Male	Female	Male	Female	Male	Female	Male	Female	Male	Female	Male	Female	Both
Tigray	1726	1945	936	970	680	791	1243	1740	805	1261	437	609	787	1351	237	466	6851	9133	15984
Afar	500	418	144	182	81	72	115	68	63	94	27	42	241	245	103	73	1274	1194	2468
Amhara	7327	7990	3703	4143	3522	3092	1720	2064	2895	4567	1351	1920	3443	5388	4202	5509	28163	34673	62836
Oromia	4706	4148	3577	3270	3004	2899	5280	5563	3883	3560	1637	1418	5685	5706	4037	4490	31809	31054	62863
Somale	583	264	275	186	257	184	172	115	143	92	67	56	47	55	119	86	1663	1038	2701
Benishangul-Gumuz	450	406	243	250	219	207	277	249	352	237	142	101	691	527	237	152	2611	2129	4740
SNNPR	7723	6862	2395	2173	2270	2139	2138	2066	2073	2098	1551	1360	7085	5394	5050	3616	30285	25708	55993
Gambella	118	109	17	17	57	67	124	177	237	271	87	104	80	47	116	60	836	852	1688
Harari	186	196	68	70	70	49	81	69	113	111	72	69	231	226	193	273	1014	1063	2077
Addis Ababa	217	164	136	94	155	116	2294	2039	2809	2910	1732	1927	4662	6095	3415	5681	15420	19026	34446
Dire Dawa	35	20	23	22	14	9	179	139	84	64	39	39	168	221	347	438	889	952	1841
Total	23571	22522	11517	11377	10329	9625	13623	14289	13457	15265	7142	7645	23120	25255	18056	20844	120815	126822	247637

Rural - 1994 E.C.

Region	Grade 1		Grade 2		Grade 3		Grade 4		Grade 5		Grade 6		Grade 7		Grade 8		Total		
	Male	Female	Male	Female	Male	Female	Male	Female	Male	Female	Male	Female	Male	Female	Male	Female	Male	Female	Both
Tigray	3087	3899	1377	1892	836	1191	1605	2349	514	908	311	370	341	644	144	188	8215	11441	19656
Afar	745	455	281	136	71	42	39	37	12	6	4	5	36	26	5	4	1193	711	1904
Amhara	39174	43608	20085	23551	12647	14350	7857	8204	5796	6467	1962	1935	1425	1442	1139	1116	90085	100673	190758
Oromia	14196	9410	8651	5316	6158	3654	9562	6015	4095	2292	1562	751	2259	1413	1221	883	47704	29734	77438
Somale	127	77	83	68	79	69	86	44	47	20	13	9	1				436	287	723
Benishangul-Gumuz	1542	1217	946	706	872	573	743	434	545	329	168	92	454	177	231	58	5501	3586	9087
SNNPR	36900	25520	12979	9398	10808	7773	9989	6815	6151	3996	3711	2193	5285	3334	3970	1975	89793	61004	150797
Gambella	400	348	92	95	85	90	190	156	286	174	184	79	171	36	184	27	1592	1005	2597
Harari	138	80	72	49	61	30	68	29	71	14	12	1	33		33	5	488	208	696
Addis Ababa							9	10									9	10	19
Dire Dawa	35	27	45	14	32	31	42	21	13	1	3	2	11		6		187	96	283
Total	96344	84641	44611	41225	31649	27803	30190	24114	17530	14207	7930	5437	10016	7072	6933	4256	245203	208755	453958

Repeaters in Secondary School Regular

Government and Non-Government School - 1994 E.C.

Region	Grade 9		
	Male	Female	Both
Tigray	381	611	992
Afar	130	851	981
Amhara	5471	6826	12297
Oromia	10765	8586	19351
Somale	73	88	161
Benishangul-Gumuz	271	230	501
SNNPR	6694	4247	10941
Gambella	104	51	155
Harari	274	205	479
Addis Ababa	2418	3132	5550
Dire Dawa	422	360	782
Total	27003	25187	52190

Government School - 1994 E.C.

Region	Grade 9		
	Male	Female	Both
Tigray	366	606	972
Afar	130	851	981
Amhara	5465	6818	12283
Oromia	10675	8461	19136
Somale	73	88	161
Benishangul-Gumuz	271	230	501
SNNPR	6650	4212	10862
Gambella	104	51	155
Harari	274	205	479
Addis Ababa	2157	2791	4948
Dire Dawa	422	360	782
Total	26587	24673	51260

Non-Government School - 1994 E.C.

Region	Grade 9		
	Male	Female	Both
Tigray	15	5	20
Afar			
Amhara	6	8	14
Oromia	90	125	215
Somale			
Benishangul-Gumuz			
SNNPR	44	35	79
Gambella			
Harari			
Addis Ababa	261	341	602
Dire Dawa			
Total	416	514	930

Urban School - 1994 E.C.

Region	Grade 9		
	Male	Female	Both
Tigray	381	611	992
Afar	130	851	981
Amhara	5298	6652	11950
Oromia	10378	8144	18522
Somale	73	88	161
Benishangul-Gumuz	258	213	471
SNNPR	6469	4103	10572
Gambella	104	51	155
Harari	274	205	479
Addis Ababa	2418	3132	5550
Dire Dawa	422	360	782
Total	26205	24410	50615

Rural School - 1994 E.C.

Region	Total		
	Male	Female	Both
Tigray			
Afar			
Amhara	173	174	347
Oromia	387	442	829
Somale			
Benishangul-Gumuz	13	17	30
SNNPR	225	144	369
Gambella			
Harari			
Addis Ababa			
Dire Dawa			
Total	798	777	1575

Sections in Primary School Regular

Government and Non-Government School - 1994 E.C.

Region	Grade 1	Grade 2	Grade 3	Grade 4	Grade 5	Grade 6	Grade 7	Grade 8	Total
Tigray	1994	1690	1400	1189	929	726	610	485	9023
Afar	167	132	124	97	55	54	38	28	695
Amhara	5321	4763	4401	3866	2706	2229	1394	977	25657
Oromia	8398	7209	6584	6061	4094	3407	2519	1905	40177
Somale	413	289	219	190	140	96	83	44	1474
Benishangul-Gumuz	383	313	290	300	165	139	88	57	1735
SNNPR	5377	3644	3236	2994	2305	1987	1602	1079	22224
Gambella	136	118	107	105	71	54	34	29	654
Harari	89	74	72	71	62	54	50	42	514
Addis Ababa	893	794	749	766	739	720	768	686	6115
Dire Dawa	103	91	86	91	78	63	53	55	620
Total	23274	19117	17268	15730	11344	9529	7239	5387	108888

Government School - 1994 E.C.

Region	Grade 1	Grade 2	Grade 3	Grade 4	Grade 5	Grade 6	Grade 7	Grade 8	Total
Tigray	1949	1649	1367	1160	909	706	597	472	8809
Afar	162	127	119	94	54	53	38	28	675
Amhara	5275	4725	4368	3835	2683	2210	1375	961	25432
Oromia	8121	6972	6381	5879	3955	3287	2434	1826	38855
Somale	407	283	215	187	138	94	80	41	1445
Benishangul-Gumuz	378	308	285	297	165	139	88	57	1717
SNNPR	5158	3491	3102	2872	2215	1906	1561	1048	21353
Gambella	134	117	107	105	71	54	34	29	651
Harari	80	66	64	64	56	49	45	38	462
Addis Ababa	432	395	359	386	383	370	421	343	3089
Dire Dawa	83	71	69	74	63	50	40	41	491
Total	22179	18204	16436	14953	10692	8918	6713	4884	102979

Non-Government School - 1994 E.C.

Region	Grade 1	Grade 2	Grade 3	Grade 4	Grade 5	Grade 6	Grade 7	Grade 8	Total
Tigray	45	41	33	29	20	20	13	13	214
Afar	5	5	5	3	1	1			20
Amhara	46	38	33	31	23	19	19	16	225
Oromia	277	237	203	182	139	120	85	79	1322
Somale	6	6	4	3	2	2	3	3	29
Benishangul-Gumuz	5	5	5	3					18
SNNPR	219	153	134	122	90	81	41	31	871
Gambella	2	1							3
Harari	9	8	8	7	6	5	5	4	52
Addis Ababa	461	399	390	380	356	350	347	343	3026
Dire Dawa	20	20	17	17	15	13	13	14	129
Total	1095	913	832	777	652	611	526	503	5909

Sections in Primary School Regular

Urban School - 1994 E.C.

Region	Grade 1	Grade 2	Grade 3	Grade 4	Grade 5	Grade 6	Grade 7	Grade 8	Total
Tigray	485	392	337	301	306	262	347	282	2712
Afar	65	38	39	35	30	31	29	20	287
Amhara	970	842	796	734	779	668	826	587	6202
Oromia	1834	1626	1545	1575	1472	1276	1472	1131	11931
Somale	218	162	128	111	92	68	67	35	881
Benishangul-Gumuz	54	41	43	73	45	40	43	29	368
SNNPR	837	590	542	516	485	433	735	474	4612
Gambella	21	17	13	17	24	18	16	14	140
Harari	51	45	41	41	42	39	44	38	341
Addis Ababa	889	788	745	762	739	720	768	686	6097
Dire Dawa	63	61	57	65	63	51	47	53	460
Total	5487	4602	4286	4230	4077	3606	4394	3349	34031

Rural School - 1994 E.C.

Region	Grade 1	Grade 2	Grade 3	Grade 4	Grade 5	Grade 6	Grade 7	Grade 8	Total
Tigray	1509	1298	1063	888	623	464	263	203	6311
Afar	102	94	85	62	25	23	9	8	408
Amhara	4351	3921	3605	3132	1927	1561	568	390	19455
Oromia	6564	5583	5039	4486	2622	2131	1047	774	28246
Somale	195	127	91	79	48	28	16	9	593
Benishangul-Gumuz	329	272	247	227	120	99	45	28	1367
SNNPR	4540	3054	2694	2478	1820	1554	867	605	17612
Gambella	115	101	94	88	47	36	18	15	514
Harari	38	29	31	30	20	15	6	4	173
Addis Ababa	4	6	4	4					18
Dire Dawa	40	30	29	26	15	12	6	2	160
Total	17787	14515	12982	11500	7267	5923	2845	2038	74857

Sections in Secondary Schools Regular

Government and Non-Government School - 1994 E.C.

Region	Grade 9	Grade 10	Grade 11	Grade 12	Total
Tigray	340	376	70	117	903
Afar	15	12	4	1	32
Amhara	618	399	185	354	1556
Oromia	1289	607	167	772	2835
Somale	20	12	2	5	39
Benishangul-Gumuz	26	32	8	25	91
SNNPR	338	495	84	354	1271
Gambella	18	9	2	7	36
Harari	30	17	4	29	80
Addis Ababa	526	375	140	443	1484
Dire Dawa	23	34	3	33	93
Total	3243	2368	669	2140	8420

Government School - 1994 E.C.

Region	Grade 9	Grade 10	Grade 11	Grade 12	Total
Tigray	331	367	67	115	880
Afar	15	12	4	1	32
Amhara	615	397	185	354	1551
Oromia	1266	592	159	760	2777
Somale	20	12	2	5	39
Benishangul-Gumuz	26	32	8	25	91
SNNPR	332	488	84	339	1243
Gambella	18	9	2	7	36
Harari	29	16	4	27	76
Addis Ababa	445	323	120	404	1292
Dire Dawa	19	31	3	31	84
Total	3116	2279	638	2068	8101

Non-Government School - 1994 E.C.

Region	Grade 9	Grade 10	Grade 11	Grade 12	Total
Tigray	9	9	3	2	23
Afar					
Amhara	3	2			5
Oromia	23	15	8	12	58
Somale					
Benishangul-Gumuz					
SNNPR	6	7		15	28
Gambella					
Harari	1	1		2	4
Addis Ababa	81	52	20	39	192
Dire Dawa	4	3		2	9
Total	127	89	31	72	319

Sections in Secondary School Regular

Urban School - 1994 E.C.

Region	Grade 9	Grade 10	Grade 11	Grade 12	Total
Tigray	323	368	70	117	878
Afar	15	12	4	1	32
Amhara	592	386	185	347	1510
Oromia	1265	591	165	739	2760
Somale	20	12	2	5	39
Benishangul-Gumuz	23	30	8	25	86
SNNPR	311	477	81	338	1207
Gambella	12	6	2	7	27
Harari	30	17	4	29	80
Addis Ababa	526	375	140	443	1484
Dire Dawa	23	34	3	33	93
Total	3140	2308	664	2084	8196

Rural School - 1994 E.C.

Region	Grade 9	Grade 10	Grade 11	Grade 12	Total
Tigray	17	8			25
Afar					
Amhara	26	13		7	46
Oromia	24	16	2	33	75
Somale					
Benishangul-Gumuz	3	2			5
SNNPR	27	18	3	16	64
Gambella	6	3			9
Harari					
Addis Ababa					
Dire Dawa					
Total	103	60	5	56	224

Teachers in Primary Schools by Qualification
GRADES 1-4 - REGULAR

Government and Non-Government - 1994 (2001/02)

Region	Sex	Grade 6 & Below	Grade 7 & 8	Grade 9 & 10	Grade 11 & 12	TTI	TTC	12+ Sh. Tr.	Sport	Tech. & Voc.	Hand Craft	Agr.	Music	Art	12 + 1	12 + 2	12 + 3	Diploma	B.A/ B.Sc	M.A M.Sc	Others	Not Reported	Total		
																							Male	Fem	Both
Tigray	M	12	1	24	56	2530	43	194	1	3			3	1	8	2	2	3	8		5	1	2897	2938	5835
	F	13	1	2	44	2634	36	196		1					3			1	3		4				
Afar	M	22	21	19	24	373	9	11															479	204	683
	F	7	3		16	171	2	3	1												1				
Amhara	M	12		35	408	9574	7	229	123						12		1	15	4		1	1	10422	8707	19129
	F	6	1	27	549	7518	16	395	173	6					2		4	9	1						
Oromia	M		50		435	15720	12	144	1	1		1	1		52	9	7	32	3	1	13		16482	11123	27605
	F		11		104	10937	8	41	1						15			3	1		2				
Somale	M	16			88	702		418	1			1			5		2	4					1237	297	1534
	F	7			17	188		85																	
Benishangool-Gumuz	M				13	978	6	4							2						1		1004	578	1582
	F			1	5	560	6								6										
SNNPR	M	56	4	31	355	10020	405	464	10	2	1	1	1	1	28	4	12	25	7		8		11435	4791	16226
	F	24	1	1	130	4314	186	102	1			2			12		5	11	1		1				
Gambella	M	78	2			467	17																564	139	703
	F	20				118	1																		
Harari	M			3	3	221									9	1		11	6			1	255	374	629
	F			3	5	359							1		2			2	2						
Addis Ababa	M	4		21	125	1264		53	23	2		6	7	72	15	10	232	49		5		228	2116	2566	4682
	F	1	1	7	85	1900		102	24	2	1	10	14	43	8	2	144	37	2	1		182			
Dire Dawa	M				4	275			22	1	2		1		7	3		6					321	235	556
	F			2	2	211			10					3	3	1	1	1	1						
Total	M	200	78	133	1511	42124	499	1517	181	9	3	9	13	74	138	29	256	145	28	6	28	231	47212	31952	79164
	F	78	18	43	957	28910	255	924	210	9	1	12	15	46	51	3	154	64	11	1	8	182			

Teachers in Primary Schools by Qualification
GRADES 1-4 - REGULAR

Government - 1994 (2001/02)

Region	Sex	Grade 6 & Below	Grade 7 & 8	Grade 9 & 10	Grade 11 & 12	TTI	TTC	12+ Sh. Tr.	Sport	Tech. & Voc.	Hand Craft	Agr.	Music	Art	12 + 1	12 + 2	12 + 3	Diploma	B.A/ B.Sc	M.A M.Sc	Others	Not Reported	Total			
																							Male	Fem	Both	
Tigray	M	12	1	10	38	2477	42	186		1			2	7		2		1	3		5	1	2788	2867	5655	
	F	13	1	1	40	2587	34	184						3							4					
Afar	M	19	20	19	23	362	9	11																463	199	662
	F	7	3		16	167	2	2	1													1				
Amhara	M	12		33	400	9482	7	227	123					8				11				1	1	10305	8633	18938
	F	6	1	27	537	7472	15	390	173	6								6								
Oromia	M		24		262	15309	6	109	1			1		37	6	3		21	3	1	8			15791	10749	26540
	F		7		42	10667	1	16						12				1	1		2					
Somale	M	16			86	689		404	1			1		3		1		3						1204	286	1490
	F	7			17	180		82																		
Benishangool-Gumuz	M				13	968	6	4						2								1		994	572	1566
	F			1	3	556	6							6												
SNNPR	M	52		16	268	9676	377	435	7			1		23	2	12		20	1		6			10896	4609	15505
	F	24	1	1	113	4171	182	94				1		12		3		6			1					
Gambella	M	76	2			467	17																	562	138	700
	F	19				118	1																			
Harari	M					207								8				2						217	348	565
	F				2	342							1	2				1								
Addis Ababa	M	1		3	10	567		14	3				2	27	4	1	32			1		198		863	1474	2337
	F		1	2	8	1244		35		1	1		1	20			18					143				
Dire Dawa	M				1	244			5		1				2			3						256	194	450
	F					190			2				1	1												
Total	M	188	47	81	1101	40448	464	1390	140	1	1	3	4	27	94	9	50	61	7	2	21	200	44339	30069	74408	
	F	76	14	32	778	27694	241	803	176	7	1	1	2	21	36		21	14	1		8	143				

Teachers in Primary Schools by Qualification
GRADES 1-4 - REGULAR

Non-Government - 1994 (2001/02)

Region	Sex	Grade 6 & Below	Grade 7 & 8	Grade 9 & 10	Grade 11 & 12	TTI	TTC	12+ Sh. Tr.	Sport	Tech. & Voc.	Hand Craft	Agr.	Music	Art	12 + 1	12 + 2	12 + 3	Diploma	B.A/ B.Sc	M.A M.Sc	Others	Not Reported	Total		
																							Male	Fem	Both
Tigray	M			14	18	53	1	8	1	2			1	1	1	2		2	5				109	71	180
	F			1	4	47	2	12		1								1	3						
Afar	M	3	1		1	11																	16	5	21
	F					4		1																	
Amhara	M			2	8	92		2							4		1	4	4				117	74	191
	F				12	46	1	5							2		4	3	1						
Oromia	M		26		173	411	6	35		1			1		15	3	4	11				5	691	374	1065
	F		4		62	270	7	25	1						3			2							
Somale	M				2	13		14							2		1	1					33	11	44
	F					8		3																	
Benishangool-Gumuz	M					10																	10	6	16
	F				2	4																			
SNNPR	M	4	4	15	87	344	28	29	3	2	1		1	1	5	2		5	6		2		539	182	721
	F				17	143	4	8	1			1					2	5	1						
Gambella	M	2																					2	1	3
	F	1																							
Harari	M			3	3	14									1	1		9	6			1	38	26	64
	F			3	3	17												1	2						
Addis Ababa	M	3		18	115	697		39	20	2		6	5	45	11	9	200	49		4		30	1253	1092	2345
	F	1		5	77	656		67	24	1		10	13	23	8	2	126	37	2	1		39			
Dire Dawa	M				3	31			17	1	1		1		5	3		3					65	41	106
	F			2	2	21			8					2	2	1	1	1	1						
Total	M	12	31	52	410	1676	35	127	41	8	2	6	9	47	44	20	206	84	21	4	7	31	2873	1883	4756
	F	2	4	11	179	1216	14	121	34	2		11	13	25	15	3	133	50	10	1		39			

Teachers in Primary Schools by Qualification
GRADES 1-4 - REGULAR

Urban - 1994 (2001/02)

Region	Sex	Grade 6 & Below	Grade 7 & 8	Grade 9 & 10	Grade 11 & 12	TTI	TTC	12+ Sh. Tr.	Sport	Tech. & Voc.	Hand Craft	Agr.	Music	Art	12 + 1	12 + 2	12 + 3	Diploma	B.A/ B.Sc	M.A M.Sc	Others	Not Reported	Total		
																							Male	Fem	Both
Tigray	M	1		7	5	687	1	20	1	1			2	1	6	2	2	3	5		4		748	937	1685
	F	1		1	6	897	6	19							3			1	3						
Afar	M	9	12	12	9	145	1																188	103	291
	F	3	3		6	91																			
Amhara	M			3	21	1980	3	16	8						11		1	9	4				2056	2248	4304
	F				62	2138	16	14	3	1					2		4	7	1						
Oromia	M		8		78	4068	9	63		1		1			33	4	5	22	1		11		4304	4543	8847
	F		2		60	4433	6	24	1						13			2	1		1				
Somale	M	10			46	477		245	1			1			5		1	4					790	253	1043
	F	7			16	171		59																	
Benishangool-Gumuz	M				1	158	1	1															161	105	266
	F					103	2																		
SNNPR	M	2		6	67	2125	104	67	5	2	1	1	1	1	20	3	7	17	6		2		2437	1803	4240
	F	4			59	1608	78	25				1			12		4	10	1		1				
Gambella	M					88	5																93	50	143
	F					49	1																		
Harari	M			3	3	101									7	1		11	6			1	133	264	397
	F			3	5	250									2			2	2						
Addis Ababa	M	4		21	125	1255		53	23	2		6	7	72	15	10	232	49		5		223	2102	2550	4652
	F	1	1	7	85	1891		102	24	2	1	10	14	43	8	2	144	37	2	1		175			
Dire Dawa	M				4	156			18	1	2		1		7	3		3					195	186	381
	F			2	2	164			8					3	3	1	1	1	1						
Total	M	26	20	52	359	11240	124	465	56	7	3	9	11	74	104	23	248	118	22	5	17	224	13207	13042	26249
	F	16	6	13	301	11795	109	243	36	3	1	11	14	46	43	3	153	60	11	1	2	175			

Teachers in Primary Schools by Qualification
GRADES 1-4 - REGULAR

Rural - 1994 (2001/02)

Region	Sex	Grade 6 & Below	Grade 7 & 8	Grade 9 & 10	Grade 11 & 12	TTI	TTC	12+ Sh. Tr.	Sport	Tech. & Voc.	Hand Craft	Agr.	Music	Art	12+1	12+2	12+3	Diploma	B.A/ B.Sc	M.A M.Sc	Others	Not Reported	Total			
																							Male	Fem	Both	
Tigray	M	11	1	17	51	1843	42	174		2			1		2				3		1	1	2149	2001	4150	
	F	12	1	1	38	1737	30	177		1											4					
Afar	M	13	9	7	15	228	8	11															291	101	392	
	F	4			10	80	2	3	1													1				
Amhara	M	12		32	387	7594	4	213	115						1				6			1	1	8366	6459	14825
	F	6	1	27	487	5380		381	170	5									2							
Oromia	M		42		357	11652	3	81	1				1	19	5	2		10	2	1	2		12178	6580	18758	
	F		9		44	6504	2	17						2				1			1					
Somale	M	6			42	225		173									1						447	44	491	
	F				1	17		26																		
Benishangool-Gumuz	M				12	820	5	3							2							1	843	473	1316	
	F			1	5	457	4								6											
SNNPR	M	54	4	25	288	7895	301	397	5						8	1	5	8	1			6	8998	2988	11986	
	F	20	1	1	71	2706	108	77	1			1					1	1								
Gambella	M	78	2			379	12																471	89	560	
	F	20				69																				
Harari	M					120									2								122	110	232	
	F					109							1													
Addis Ababa	M					9																5	14	16	30	
	F					9																7				
Dire Dawa	M					119			4									3					126	49	175	
	F					47			2																	
Total	M	174	58	81	1152	30884	375	1052	125	2			2		34	6	8	27	6	1	11	7	34005	18910	52915	
	F	62	12	30	656	17115	146	681	174	6		1	1		8		1	4			6	7				

Teachers in Primary Schools by Qualification
GRADES 5-8 - REGULAR

Government and Non-Government - 1994 (2001/02)

Region	Sex	Grade 6 & Below	Grade 7 & 8	Grade 9 & 10	Grade 11 & 12	TTI	TTC	12+ Sh. Tr.	Sport	Tech. & Voc.	Hand Craft	Agr.	Music	Art	12 + 1	12 + 2	12 + 3	Diploma	B.A/ B.Sc	M.A M.Sc	Others	Not Reported	Total		
																							Male	Fem	Both
Tigray	M	12		1	15	1109	435	23	3			1	2		81	33	13	407	7		9	2	2153	536	2689
	F	8			1	361	83	2							18	3	2	56			2				
Afar	M	1	2	8		74	112		2			1			4	2	1	26					233	22	255
	F					13	7				1							1							
Amhara	M	10		1	19	4611	1645	17	19	5	6	3	2	3	106	20	16	828	12		7	1	7331	1470	8801
	F				17	921	349	8	2		2		1	1	8	7	9	145							
Oromia	M		8		65	12760	997	102	8	2	4	27		3	335	101	37	680	55	3	23	6	15216	2084	17300
	F				8	1637	234	12	1			5		1	47	28	3	101	4		3				
Somale	M		11	8	11	528		150							12	3	2	22	7				754	108	862
	F				2	67		37								2									
Benishangool-Gumuz	M					144	65		1						14	2	3	86					315	49	364
	F					30	5								4	1	1	8							
SNNPR	M	11		1	116	7,155	898	118	2	1	2	15	2	1	248	90	60	530	32	1	7		9290	1415	10705
	F	2		1	49	1,003	165	13				4		2	41	18	8	102	4		3				
Gambella	M	17	1			174	53	15							7		1	25					293	58	351
	F	4				40	10	1							1			2							
Harari	M				6	199									21	8	5	125	10				374	129	503
	F				2	102									7			18							
Addis Ababa	M		1	5	68	730		41	20	6	1	4	6	199	114	78	1911	241	12	6		501	3944	1581	5525
	F				8	229		14	5		1	5	2	37	27	5	871	34	8	2		333			
Dire Dawa	M				1	103				1	5	1	1		34	12	14	133	10				315	48	363
	F					27									6	1	1	13							
Total	M	51	23	24	301	27587	4205	466	55	15	18	52	13	206	976	349	2063	3103	145	10	46	510	40218	7500	47718
	F	14		1	87	4430	853	87	8		3	15	3	41	159	65	895	480	16	2	8	333			

**Teachers in Primary Schools by Qualification
GRADES 5-8 - REGULAR**

Government - 1994 (2001/02)

Region	Sex	Grade 6 & Below	Grade 7 & 8	Grade 9 & 10	Grade 11 & 12	TTI	TTC	12+ Sh. Tr.	Sport	Tech. & Voc.	Hand Craft	Agr.	Music	Art	12 + 1	12 + 2	12 + 3	Diploma	B.A/ B.Sc	M.A M.Sc	Others	Not Reported	Total		
																							Male	Fem	Both
Tigray	M	12			7	1093	422	20	3			1	2		79	20	13	401			8	2	2083	520	2603
	F	8			1	347	83	1							18	2	2	56			2				
Afar	M	1	2	8		74	112		2			1			4	2	1	26					233	22	255
	F					13	7				1							1							
Amhara	M	10		1	17	4559	1627	17	19	5	6	3	2	3	103	19	14	804	7		4	1	7221	1462	8683
	F				17	915	348	8	2		2		1	1	8	7	9	144							
Oromia	M		7		48	12460	924	92	7	1	3	26		3	305	92	23	601	30		17	1	14640	1959	16599
	F				4	1572	211	10	1			5		1	40	24	3	84	1		3				
Somale	M		11	8	11	510		147							10	3	2	22	7				731	107	838
	F				2	67		36								2									
Benishangool-Gumuz	M					144	65		1						14	2	3	86					315	49	364
	F					30	5								4	1	1	8							
SNNPR	M	10			95	6939	857	101	2	1	1	15	2	1	241	83	50	487	14		7		8906	1377	10283
	F	1		1	48	981	159	12				4			41	17	8	100	2		3				
Gambella	M	17	1			174	53	15							7		1	25					293	58	351
	F	4				40	10	1							1			2							
Harari	M				1	184									17	4	3	117					326	120	446
	F					96									7			17							
Addis Ababa	M			1	5	285		2	9	2		1	1	89	64	25	947	6		2	397	1836	1155	2991	
	F				1	144		2	3		1	3		27	23	5	641	4		1	300				
Dire Dawa	M					94					3	1	1		33	8	8	101					249	48	297
	F					27									6	1	1	13							
Total	M	50	21	18	184	26516	4060	394	43	9	13	48	8	96	877	258	1065	2676	58	2	36	401	36833	6877	43710
	F	13		1	73	4232	823	70	6		3	13	1	29	148	59	665	429	3	1	8	300			

Teachers in Primary Schools by Qualification
GRADES 5-8 - REGULAR

Non-Government - 1994 (2001/02)

Region	Sex	Grade 6 & Below	Grade 7 & 8	Grade 9 & 10	Grade 11 & 12	TTI	TTC	12+ Sh. Tr.	Sport	Tech. & Voc.	Hand Craft	Agr.	Music	Art	12 + 1	12 + 2	12 + 3	Diploma	B.A/ B.Sc	M.A M.Sc	Others	Not Reported	Total			
																							Male	Fem	Both	
Tigray	M			1	8	16	13	3							2	13		6	7		1			70	16	86
	F					14		1								1										
Afar	M																									
	F																									
Amhara	M				2	52	18								3	1	2	24	5		3			110	8	118
	F					6	1											1								
Oromia	M		1		17	300	73	10	1	1	1	1			30	9	14	79	25	3	6	5		576	125	701
	F				4	65	23	2							7	4		17	3							
Somale	M					18		3							2									23	1	24
	F							1																		
Benishangool-Gumuz	M																									
	F																									
SNNPR	M	1		1	21	216	41	17			1				7	7	10	43	18	1				384	38	422
	F	1			1	22	6	1						2		1		2	2							
Gambella	M																									
	F																									
Harari	M				5	15									4	4	2	8	10					48	9	57
	F				2	6												1								
Addis Ababa	M		1	4	63	445		39	11	4	1	3	5	110	50	53	964	235	12	4		104		2108	426	2534
	F				7	85		12	2			2	2	10	4		230	30	8	1		33				
Dire Dawa	M				1	9				1	2				1	4	6	32	10					66		66
	F																									
Total	M	1	2	6	117	1071	145	72	12	6	5	4	5	110	99	91	998	427	87	8	10	109		3385	623	4008
	F	1			14	198	30	17	2			2	2	12	11	6	230	51	13	1		33				

**Teachers in Primary Schools by Qualification
GRADES 5-8 - REGULAR**

Urban - 1994 (2001/02)

Region	Sex	Grade 6 & Below	Grade 7 & 8	Grade 9 & 10	Grade 11 & 12	TTI	TTC	12+ Sh. Tr.	Sport	Tech. & Voc.	Hand Craft	Agr.	Music	Art	12 + 1	12 + 2	12 + 3	Diploma	B.A/ B.Sc	M.A M.Sc	Others	Not Reported	Total		
																							Male	Fem	Both
Tigray	M				6	497	177	6	1			1	1		59	25	12	197	7		7		996	293	1289
	F				1	195	41								15	2	2	35			2				
Afar	M	1	2	6		53	85		2			1			2	2		19					173	14	187
	F					8	4					1						1							
Amhara	M			1	1	1686	802	8	13	4		3	2	3	96	12	6	533	11		5	1	3187	733	3920
	F				1	461	161	3	1				1	1	7	5	4	88							
Oromia	M				21	5564	749	65	7	2	4	23		3	273	87	30	526	47	3	21	6	7431	1449	8880
	F				5	1087	178	9	1			3		1	45	25	3	85	4		3				
Somale	M		11	8	10	441		102							10	2	1	21	7				613	83	696
	F				1	54		26								2									
Benishangool-Gumuz	M					57	25								3		1	71					157	26	183
	F					16	1								4			5							
SNNPR	M	3			26	2,003	431	25	1		2	9	2	1	135	62	31	365	25	1	4		3126	733	3859
	F			1	16	471	114	4				3		2	25	13	4	77	3						
Gambella	M					62	27	7							7		1	17					121	30	151
	F					19	8								1			2							
Harari	M				6	134									21	4	2	117	10				294	101	395
	F				2	74									7			18							
Addis Ababa	M		1	5	68	730		41	20	6	1	4	6	199	114	78	1911	241	12	6		501	3944	1581	5525
	F				8	229		14	5		1	5	2	37	27	5	871	34	8	2		333			
Dire Dawa	M				1	97				1	5	1	1		34	11	11	121	10				293	47	340
	F					26									6	1	1	13							
Total	M	4	14	20	139	11324	2296	254	44	13	12	42	12	206	754	283	2006	2228	129	10	37	508	20335	5090	25425
	F			1	34	2640	507	56	7		1	12	3	41	137	53	885	358	15	2	5	333			

Teachers in Primary Schools by Qualification
GRADES 5-8 - REGULAR

Rural - 1994 (2001/02)

Region	Sex	Grade 6 & Below	Grade 7 & 8	Grade 9 & 10	Grade 11 & 12	TTI	TTC	12+ Sh. Tr.	Sport	Tech. & Voc.	Hand Craft	Agr.	Music	Art	12 + 1	12 + 2	12 + 3	Diploma	B.A/ B.Sc	M.A M.Sc	Others	Not Reported	Total		
																							Male	Fem	Both
Tigray	M	12		1	9	612	258	17	2				1		22	8	1	210			2	2	1157	243	1400
	F	8				166	42	2							3	1		21							
Afar	M			2		21	27								2		1	7					60	8	68
	F					5	3																		
Amhara	M	10			18	2925	843	9	6	1	6				10	8	10	295	1		2		4144	737	4881
	F				16	460	188	5	1		2				1	2	5	57							
Oromia	M		8		44	7196	248	37	1			4			62	14	7	154	8		2		7785	635	8420
	F				3	550	56	3				2			2	3		16							
Somale	M				1	87		48							2	1	1	1					141	25	166
	F				1	13		11																	
Benishangool-Gumuz	M					87	40		1						11	2	2	15					158	23	181
	F					14	4									1	1	3							
SNNPR	M	8		1	90	5,152	467	93	1	1		6			113	28	29	165	7		3		6164	682	6846
	F	2			33	532	51	9				1			16	5	4	25	1		3				
Gambella	M	17	1			112	26	8										8					172	28	200
	F	4				21	2	1																	
Harari	M					65										4	3	8					80	28	108
	F					28																			
Addis Ababa	M																								
	F																								
Dire Dawa	M					6										1	3	12					22	1	23
	F					1																			
Total	M	47	9	4	162	16263	1909	212	11	2	6	10	1		222	66	57	875	16		9	2	19883	2410	22293
	F	14			53	1790	346	31	1		2	3			22	12	10	122	1		3				

Teachers in Secondary Schools by Qualification
GRADES 9-12 - REGULAR

Government and Non-Government - 1994 (2001/02)

Region	Sex	Ethiopian															Expatriates				Total			
		Grade 8 & Below	Grade 9 & 10	Grade 11 & 12	TTI	TTC	Music	Art	12+1	12+2	12+3	Diploma	B.A/ B.Sc	M.A M.Sc	Others	Not Reported	Total	Diploma	B.A/ B.Sc	M.A M.Sc	Total	Ethiopian and Expatriates		
																							Male	Fem
Tigray	M				51	87	15		17	11	27	453	75	8	5		749	11	3	2	16			
	F				2	9			2		1	61	4				79	1	2		3	765	82	847
Afar	M					3					11	23	25				62							
	F								1								1					62	1	63
Amhara	M				113	385			3	3	44	864	1134	16	6		2568		17	4	21			
	F				10	29					1	54	42				136					2589	136	2725
Oromia	M				414	1737			85	268	242	422	1324	53	15		4560		1	1	2			
	F				19	170			3	17	19	29	49	1	1		308			4	4	4562	312	4874
Somale	M	6	6		36			3	1	4	1	46	48				151		3		3			
	F				1							3					4					154	4	158
Benishangool-Gumuz	M				3	10					3	143	83				242							
	F				3							6	2				11					242	11	253
SNNPR	M			1	233	231	23	2	16	34	47	863	260	17	20		1747		4	4	8			
	F				25	18				5	1	76	23				148		1		1	1755	149	1904
Gambella	M				17	12						17	18	1			65		1	1	2			
	F																	1		1	2	67	2	69
Harari	M				6				3	10	12	31	116	1	1		180		4		4			
	F				1					1	4	6	6				18					184	18	202
Addis Ababa	M				3		1	2	35	66	435	762	876	112	5	3	2300	14	18	120	152			
	F				1				10	15	73	112	98	13	3		325	7	12	27	46	2452	371	2823
Dire Dawa	M			1					1	8	12	30	113				165							
	F									1		4	3				8					165	8	173
Total	M	6	6	2	876	2465	39	7	161	404	834	3654	4072	208	52	3	12789	25	51	132	208			
	F				62	226			16	39	99	351	227	14	4		1038	9	15	32	56	12997	1094	14091

Teachers in Secondary Schools by Qualification
GRADES 9-12 - REGULAR

Government - 1994 (2001/02)

Region	Sex	Ethiopian															Expatriates				Total			
		Grade 8 & Below	Grade 9 & 10	Grade 11 & 12	TTI	TTC	Music	Art	12 + 1	12 + 2	12 + 3	Diploma	B.A/ B.Sc	M.A M.Sc	Others	Not Reported	Total	Diploma	B.A/ B.Sc	M.A M.Sc	Total	Ethiopian and Expatriates		
																						Male	Fem	Both
Tigray	M				51	87	15		17	11	24	440	51	7	1		704	11	2		13			
	F				2	9			2		1	58	3				75	1	2		3	717	78	795
Afar	M					3					11	23	25				62							
	F								1								1					62	1	63
Amhara	M				113	385			3	3	44	864	1127	16	5		2560		17	4	21			
	F				10	29					1	54	42				136					2581	136	2717
Oromia	M				409	1726			85	262	233	420	1258	46	12		4451			1	1			
	F				18	169			3	17	19	29	48	1			304			1	1	4452	305	4757
Somale	M	6	6		36				3	1	4	46	48				151		3		3			
	F				1							3					4					154	4	158
Benishangool-Gumuz	M				3	10					3	143	83				242							
	F				3							6	2				11					242	11	253
SNNPR	M			1	228	231	23	2	16	33	45	860	241	17	20		1717		4	3	7			
	F				25	18				5	1	75	20				144		1		1	1724	145	1869
Gambella	M				17	12						17	18	1			65		1	1	2			
	F																	1		1	2	67	2	69
Harari	M				6				3	10	12	31	105		1		168		4		4			
	F				1					1	4	6	6				18					172	18	190
Addis Ababa	M				1			2	34	62	392	556	706	98	4		1855		9	111	120			
	F								10	15	67	87	86	10	3		278			23	23	1975	301	2276
Dire Dawa	M			1						8	12	25	106				152							
	F									1		3	3				7					152	7	159
Total	M	6	6	2	864	2454	38	7	159	393	777	3425	3768	185	43		12127	11	40	120	171			
	F				60	225			16	39	93	321	210	11	3		978	2	3	25	30	12298	1008	13306

Teachers in Secondary Schools by Qualification
GRADES 9-12 - REGULAR

Non-Government - 1994 (2001/02)

Region	Sex	Ethiopian															Expatriates				Total			
		Grade 8 & Below	Grade 9 & 10	Grade 11 & 12	TTI	TTC	Music	Art	12 + 1	12 + 2	12 + 3	Diploma	B.A/ B.Sc	M.A M.Sc	Others	Not Reported	Total	Diploma	B.A/ B.Sc	M.A M.Sc	Total	Ethiopian and Expatriates		
																				Male	Fem	Both		
Tigray	M									3	13	24	1	4		45		1	2	3				
	F										3	1				4					48	4	52	
Afar	M																							
	F																							
Amhara	M											7		1		8								
	F																				8		8	
Oromia	M				5	11				6	9	2	66	7	3	109		1		1				
	F				1	1							1		1	4			3	3	110	7	117	
Somale	M																							
	F																							
Benishangool-Gumuz	M																							
	F																							
SNNPR	M				5					1	2	3	19			30			1	1				
	F											1	3			4					31	4	35	
Gambella	M																							
	F																							
Harari	M											11	1			12								
	F																				12		12	
Addis Ababa	M				2		1		1	4	43	206	170	14	1	3	445	14	9	9	32			
	F				1						6	25	12	3		47	7	12	4	23	477	70	547	
Dire Dawa	M								1			5	7			13								
	F											1				1					13	1	14	
Total	M				12	11	1		2	11	57	229	304	23	9	3	662	14	11	12	37			
	F				2	1					6	30	17	3	1		60	7	12	7	26	699	86	785

Teachers in Secondary Schools by Qualification
GRADES 9-12 - REGULAR

Urban - 1994 (2001/02)

Region	Sex	Ethiopian																Expatriates				Total		
		Grade 8 & Below	Grade 9 & 10	Grade 11 & 12	TTI	TTC	Music	Art	12 + 1	12 + 2	12 + 3	Diploma	B.A/ B.Sc	M.A M.Sc	Others	Not Reported	Total	Diploma	B.A/ B.Sc	M.A M.Sc	Total	Ethiopian and Expatriates		
																						Male	Fem	Both
Tigray	M				35	87	15		16	11	27	453	73	8	5		730	11	3	2	16			
	F				2	9			2		1	61	4				79	1	2		3	746	82	828
Afar	M					3					11	23	25				62							
	F								1								1					62	1	63
Amhara	M				101	355			3	3	38	836	1106	16	6		2464		16	4	20			
	F				10	28					1	52	41				132					2484	132	2616
Oromia	M				404	1700			85	263	240	422	1289	53	15		4471		1	1	2			
	F				18	167			3	17	19	29	48	1	1		303			4	4	4473	307	4780
Somale	M	6	6		36			3	1	4	1	46	48				151		3		3			474
	F				1							3					4					154	4	158
Benishangool-Gumuz	M				3	10						143	81				237							
	F				3							6	2				11					237	11	248
SNNPR	M			1	216	199	23	2	16	34	47	818	257	15	19		1647		4	4	8			
	F				23	15				5	1	72	23				139		1		1	1655	140	1795
Gambella	M				2	5						17	16	1			41		1	1	2			
	F																	1		1	2	43	2	45
Harari	M				6				3	10	12	31	116	1	1		180		4		4			
	F				1					1	4	6	6				18					184	18	202
Addis Ababa	M				3		1	2	35	66	435	762	876	112	5	3	2300	14	18	120	152			
	F				1				10	15	73	112	98	13	3		325	7	12	27	46	2452	371	2823
Dire Dawa	M			1					1	8	12	30	113				165							
	F									1		4	3				8					165	8	173
Total	M	6	6	2	806	2359	39	7	160	399	823	3581	4000	206	51	3	12448	25	50	132	207			
	F				59	219			16	39	99	345	225	14	4		1020	9	15	32	56	12655	1076	13731

Teachers in Secondary Schools by Qualification
GRADES 9-12 - REGULAR

Rural - 1994 (2001/02)

Region	Sex	Ethiopian														Expatriates				Total										
		Grade 8 & Below	Grade 9 & 10	Grade 11 & 12	TTI	TTC	Music	Art	12 + 1	12 + 2	12 + 3	Diploma	B.A/ B.Sc	M.A M.Sc	Others	Not Reported	Total	Diploma	B.A/ B.Sc	M.A M.Sc	Total	Ethiopian and Expatriates								
																					Male	Fem	Both							
Tigray	M				16				1									2						19				19		
	F																													
Afar	M																													
	F																													
Amhara	M				12	30					6	28	28						1			1		104						
	F					1						2	1											4				105	4	109
Oromia	M				10	37				5	2		35											89						
	F				1	3							1											5				89	5	94
Somale	M																													
	F																													
Benishangool-Gumuz	M										3		2											5						
	F																											5		5
SNNPR	M				17	32						45	3	2	1									100						
	F				2	3						4												9				100	9	109
Gambella	M				15	7							2											24						
	F																											24		24
Harari	M																													
	F																													
Addis Ababa	M																													
	F																													
Dire Dawa	M																													
	F																													
Total	M				70	106			1	5	11	73	72	2	1				1			1		341						
	F				3	7						6	2											18				342	18	360

Number of Schools by Grade Level

Government and Non-Government - 1994E.C.(2001/02)

<i>Region</i>	<i>Primary</i>	<i>Senior secondary</i>
<i>Tigray</i>	926	41
<i>Afar</i>	142	7
<i>Amhara</i>	2975	85
<i>Oromia</i>	4592	139
<i>Somale</i>	272	14
<i>Benishangool-Gumuz</i>	275	12
<i>SNNPR</i>	2352	84
<i>Gambella</i>	143	7
<i>Harari</i>	48	4
<i>Addis Ababa</i>	303	58
<i>Dire Dawa</i>	61	4
<i>Total</i>	12089	455

Government - 1994E.C.(2001/02)

<i>Region</i>	<i>Primary</i>	<i>Senior secondary</i>
<i>Tigray</i>	895	35
<i>Afar</i>	136	7
<i>Amhara</i>	2944	83
<i>Oromia</i>	4425	130
<i>Somale</i>	260	14
<i>Benishangool-Gumuz</i>	270	12
<i>SNNPR</i>	2231	81
<i>Gambella</i>	142	7
<i>Harari</i>	41	3
<i>Addis Ababa</i>	79	27
<i>Dire Dawa</i>	47	2
<i>Total</i>	11470	401

Non-Government - 1994E.C.(2001/02)

<i>Region</i>	<i>Primary</i>	<i>Senior secondary</i>
<i>Tigray</i>	31	6
<i>Afar</i>	6	
<i>Amhara</i>	31	2
<i>Oromia</i>	167	9
<i>Somale</i>	12	
<i>Benishangool-Gumuz</i>	5	
<i>SNNPR</i>	121	3
<i>Gambella</i>	1	
<i>Harari</i>	7	1
<i>Addis Ababa</i>	224	31
<i>Dire Dawa</i>	14	2
<i>Total</i>	619	54

Number of Schools by Grade Level

Urban - 1994E.C.(2001/02)

<i>Region</i>	<i>Primary</i>	<i>Senior secondary</i>
<i>Tigray</i>	154	39
<i>Afar</i>	40	6
<i>Amhara</i>	315	77
<i>Oromia</i>	624	136
<i>Somale</i>	128	14
<i>Benishangool-Gumuz</i>	23	10
<i>SNNPR</i>	274	74
<i>Gambella</i>	18	4
<i>Harari</i>	24	4
<i>Addis Ababa</i>	302	58
<i>Dire Dawa</i>	28	4
<i>Total</i>	1930	426

Rural - 1994E.C.(2001/02)

<i>Region</i>	<i>Primary</i>	<i>Senior secondary</i>
<i>Tigray</i>	772	2
<i>Afar</i>	102	1
<i>Amhara</i>	2660	8
<i>Oromia</i>	3968	3
<i>Somale</i>	144	
<i>Benishangool-Gumuz</i>	252	2
<i>SNNPR</i>	2078	10
<i>Gambella</i>	125	3
<i>Harari</i>	24	
<i>Addis Ababa</i>	1	
<i>Dire Dawa</i>	33	
<i>Total</i>	10159	29

Number of Schools by Compound

Government and Non-Government - 1994E.C.(2001/02)

Region	Grade 1-4	Grade 1-8	Grade 9-12	Grade 9 &10	Grade 1-12	All Schools
<i>Tigray</i>	374	545	34		7	960
<i>Afar</i>	90	50	5		2	147
<i>Amhara</i>	1274	1691	67	8	10	3050
<i>Oromia</i>	2038	2538	98	25	16	4715
<i>Somale</i>	163	107	2	10	2	284
<i>Benishangool-Gumuz</i>	158	112	7		5	282
<i>SNNPR</i>	714	1607	47	6	31	2405
<i>Gambella</i>	85	55	4		3	147
<i>Harari</i>	16	30	2		2	50
<i>Addis Ababa</i>	23	254	29	3	26	335
<i>Dire Dawa</i>	23	36	1	1	2	63
Total	4958	7025	296	53	106	12438

Government - 1994E.C.(2001/02)

Region	Grade 1-4	Grade 1-8	Grade 9-12	Grade 9 &10	Grade 1-12	All Schools
<i>Tigray</i>	360	530	30		5	925
<i>Afar</i>	85	49	5		2	141
<i>Amhara</i>	1260	1676	67	8	8	3019
<i>Oromia</i>	1977	2436	95	23	12	4543
<i>Somale</i>	154	104	2	10	2	272
<i>Benishangool-Gumuz</i>	153	112	7		5	277
<i>SNNPR</i>	675	1526	45	6	30	2282
<i>Gambella</i>	84	55	4		3	146
<i>Harari</i>	15	25	2		1	43
<i>Addis Ababa</i>	4	75	25	2		106
<i>Dire Dawa</i>	20	27	1	1		49
Total	4787	6615	283	50	68	11803

Non-Government - 1994E.C.(2001/02)

Region	Grade 1-4	Grade 1-8	Grade 9-12	Grade 9 &10	Grade 1-12	All Schools
<i>Tigray</i>	14	15	4		2	35
<i>Afar</i>	5	1				6
<i>Amhara</i>	14	15			2	31
<i>Oromia</i>	61	102	3	2	4	172
<i>Somale</i>	9	3				12
<i>Benishangool-Gumuz</i>	5					5
<i>SNNPR</i>	39	81	2		1	123
<i>Gambella</i>	1					1
<i>Harari</i>	1	5			1	7
<i>Addis Ababa</i>	19	179	4	1	26	229
<i>Dire Dawa</i>	3	9			2	14
Total	171	410	13	3	38	635

* 1993 E.C. Data

Number of Schools by Compound

Urban - 1994E.C.(2001/02)

Region	Grade 1-4	Grade 1-8	Grade 9-12	Grade 9 &10	Grade 1-12	All Schools
<i>Tigray</i>	39	108	32		7	186
<i>Afar</i>	16	22	4		2	44
<i>Amhara</i>	59	247	61	7	9	383
<i>Oromia</i>	82	526	95	25	16	744
<i>Somale</i>	53	73	2	10	2	140
<i>Benishangool-Gumuz</i>	5	15	7		3	30
<i>SNNPR</i>	52	198	44	6	24	324
<i>Gambella</i>	7	9	2		2	20
<i>Harari</i>	5	17	2		2	26
<i>Addis Ababa</i>	22	254	29	3	26	334
<i>Dire Dawa</i>	4	22	1	1	2	30
Total	344	1491	279	52	95	2261

Rural - 1994E.C.(2001/02)

Region	Grade 1-4	Grade 1-8	Grade 9-12	Grade 9 &10	Grade 1-12	All Schools
<i>Tigray</i>	335	437	2			774
<i>Afar</i>	74	28	1			103
<i>Amhara</i>	1215	1444	6	1	1	2667
<i>Oromia</i>	1956	2012	3			3971
<i>Somale</i>	110	34				144
<i>Benishangool-Gumuz</i>	153	97			2	252
<i>SNNPR</i>	662	1409	3		7	2081
<i>Gambella</i>	78	46	2		1	127
<i>Harari</i>	11	13				24
<i>Addis Ababa</i>	1					1
<i>Dire Dawa</i>	19	14				33
Total	4614	5534	17	1	11	10177

* 1993 E.C. Data

School Facilities by Compound
Primary (Grades 1-4)

Government and Non-Government - 1994E.C.(2001/02)

Region	Class Rooms	Workshops	Hand Crafts	Laboratories
Tigray	1323	2	7	2
Afar	290		2	
Amhara	5588	22	49	8
Oromia	8715	5	60	5
Somale	493	4		
Benishangool-Gumuz	664	4	22	1
SNNPR	3121	7	16	
Gambella	244		1	
Harari	68			
Addis Ababa	96			
Dire Dawa	97			
Total	20699	44	157	16

Government - 1994E.C.(2001/02)

Region	Class Rooms	Workshops	Hand Crafts	Laboratories
Tigray	1242	2	7	2
Afar	274		2	
Amhara	5331	19	46	8
Oromia	8470	4	57	5
Somale	471	4		
Benishangool-Gumuz	645	4	22	1
SNNPR	2947	7	15	
Gambella	241		1	
Harari	65			
Addis Ababa	26			
Dire Dawa	78			
Total	19790	40	150	16

Non-Government - 1994E.C.(2001/02)

Region	Class Rooms	Workshops	Hand Crafts	Laboratories
Tigray	81			
Afar	16			
Amhara	257	3	3	
Oromia	245	1	3	
Somale	22			
Benishangool-Gumuz	19			
SNNPR	174		1	
Gambella	3			
Harari	3			
Addis Ababa	70			
Dire Dawa	19			
Total	909	4	7	

Urban - 1994E.C.(2001/02)

Region	Class Rooms	Workshops	Hand Crafts	Laboratories
Tigray	112			
Afar	49			
Amhara	473	4	5	
Oromia	470		2	
Somale	189			
Benishangool-Gumuz	27			
SNNPR	253			
Gambella	23			
Harari	21			
Addis Ababa	88			
Dire Dawa	24			
Total	1729	4	7	

Rural - 1994E.C.(2001/02)

Region	Class Rooms	Workshops	Hand Crafts	Laboratories
Tigray	1211	2	7	2
Afar	241		2	
Amhara	5115	18	44	8
Oromia	8245	5	58	5
Somale	304			
Benishangool-Gumuz	637	4	22	1
SNNPR	2868	7	16	
Gambella	221		1	
Harari	47			
Addis Ababa	8			
Dire Dawa	73			
Total	18970	36	150	16

School Facilities by Compound
Primary (Grades 1-8)

Government and Non-Government - 1994E.C.(2001/02)

Region	Class Rooms	Workshops	Hand Crafts	Laboratories
Tigray	4064	4	17	29
Afar	362	2	2	3
Amhara	13339	66	144	217
Oromia	22490	67	288	117
Somale	614		4	8
Benishangool-Gumuz	947	3	6	2
SNNPR	13820	112	113	48
Gambella	323	1		2
Harari	294	2	1	6
Addis Ababa	3876	9036	29	38
Dire Dawa	393		1	3
Total	60522	9293	605	473

Government - 1994E.C.(2001/02)

Region	Class Rooms	Workshops	Hand Crafts	Laboratories
Tigray	3969		13	27
Afar	356	2	2	3
Amhara	13206	66	143	211
Oromia	21590	59	261	103
Somale	599		4	8
Benishangool-Gumuz	947	3	6	2
SNNPR	13183	95	92	37
Gambella	323	1		2
Harari	246			3
Addis Ababa	1408	9017	12	10
Dire Dawa	282			2
Total	56109	9243	533	408

Non-Government - 1994E.C.(2001/02)

Region	Class Rooms	Workshops	Hand Crafts	Laboratories
Tigray	95	4	4	2
Afar	6			
Amhara	133		1	6
Oromia	900	8	27	14
Somale	15			
Benishangool-Gumuz				
SNNPR	637	17	21	11
Gambella				
Harari	48	2	1	3
Addis Ababa	2468	19	17	28
Dire Dawa	111		1	1
Total	4413	50	72	65

Urban - 1994E.C.(2001/02)

Region	Class Rooms	Workshops	Hand Crafts	Laboratories
Tigray	1372	3	2	10
Afar	205	2	1	
Amhara	3266	23	28	71
Oromia	6746	32	102	59
Somale	448		4	8
Benishangool-Gumuz	196			
SNNPR	2578	31	18	23
Gambella	86			
Harari	171	2	1	4
Addis Ababa	3876	9036	29	38
Dire Dawa	301		1	3
Total	19245	9129	186	216

Rural - 1994E.C.(2001/02)

Region	Class Rooms	Workshops	Hand Crafts	Laboratories
Tigray	2692	1	15	19
Afar	157			3
Amhara	10073	43	116	146
Oromia	15744	35	186	58
Somale	166			
Benishangool-Gumuz	751	3	6	2
SNNPR	11242	81	95	25
Gambella	237	1		2
Harari	123			2
Addis Ababa				
Dire Dawa	92			
Total	41277	164	419	257

School Facilities by Compound
Primary (Grades 9-10)

Government and Non-Government - 1994E.C.(2001/02)

<i>Region</i>	Class Rooms	Workshops	Hand Crafts	Laboratories
<i>Amhara</i>	73	8		5
<i>Oromia</i>	247	16	10	41
<i>SNNPR</i>	72		2	7
<i>Dire Dawa</i>	30			
<i>Total</i>	422	24	12	53

Government - 1994E.C.(2001/02)

<i>Region</i>	Class Rooms	Workshops	Hand Crafts	Laboratories
<i>Amhara</i>	73	8		5
<i>Oromia</i>	218	14	6	37
<i>SNNPR</i>	72		2	7
<i>Dire Dawa</i>	30			
<i>Total</i>	393	22	8	49

Non-Government - 1994E.C.(2001/02)

<i>Region</i>	Class Rooms	Workshops	Hand Crafts	Laboratories
<i>Amhara</i>				
<i>Oromia</i>	29	2	4	4
<i>SNNPR</i>				
<i>Dire Dawa</i>				
<i>Total</i>	29	2	4	4

Urban - 1994E.C.(2001/02)

<i>Region</i>	Class Rooms	Workshops	Hand Crafts	Laboratories
<i>Amhara</i>	65	2		3
<i>Oromia</i>	247	16	10	41
<i>SNNPR</i>	72		2	7
<i>Dire Dawa</i>	30			
<i>Total</i>	414	18	12	51

Rural - 1994E.C.(2001/02)

<i>Region</i>	Class Rooms	Workshops	Hand Crafts	Laboratories
<i>Amhara</i>	8	6		2
<i>Oromia</i>				
<i>SNNPR</i>				
<i>Dire Dawa</i>				
<i>Total</i>	8	6		2

School Facilities by Compound Primary (Grades 9-12)

Government and Non-Government - 1994E.C.(2001/02)

Region	Class Rooms	Workshops	Hand Crafts	Laboratories
Tigray	393	29	12	43
Afar	17			1
Amhara	1022	79	10	139
Oromia	1490	105	44	169
Somale	34	1		1
Benishangool-Gumuz	64	12	1	11
SNNPR	732	44	24	78
Gambella	8	2	1	3
Harari	60	5	1	6
Addis Ababa	839	23	6	44
Dire Dawa	37			3
Total	4696	300	99	498

Government - 1994E.C.(2001/02)

Region	Class Rooms	Workshops	Hand Crafts	Laboratories
Tigray	364	25	12	40
Afar	17			1
Amhara	1022	79	10	139
Oromia	1470	102	42	165
Somale	34	1		1
Benishangool-Gumuz	64	12	1	11
SNNPR	713	43	24	72
Gambella	8	2	1	3
Harari	60	5	1	6
Addis Ababa	823	23	6	38
Dire Dawa	37			3
Total	4612	292	97	479

Non-Government - 1994E.C.(2001/02)

Region	Class Rooms	Workshops	Hand Crafts	Laboratories
Tigray	29	4		3
Afar				
Amhara				
Oromia	20	3	2	4
Somale				
Benishangool-Gumuz				
SNNPR	19	1		6
Gambella				
Harari				
Addis Ababa	16			6
Dire Dawa				
Total	84	8	2	19

Urban - 1994E.C.(2001/02)

Region	Class Rooms	Workshops	Hand Crafts	Laboratories
Tigray	385	29	12	41
Afar	17			1
Amhara	973	75	10	129
Oromia	1447	100	44	165
Somale	34	1		1
Benishangool-Gumuz	64	12	1	11
SNNPR	683	43	23	73
Gambella				
Harari	60	5	1	6
Addis Ababa	839	23	6	44
Dire Dawa	37			3
Total	4539	288	97	474

Rural - 1994E.C.(2001/02)

Region	Class Rooms	Workshops	Hand Crafts	Laboratories
Tigray	8			2
Afar				
Amhara	49	4		10
Oromia	43	5		4
Somale				
Benishangool-Gumuz				
SNNPR	49	1	1	5
Gambella	8	2	1	3
Harari				
Addis Ababa				
Dire Dawa				
Total	157	12	2	24

School Facilities by Compound
All Grades (1-12)

Government and Non-Government - 1994E.C.(2001/02)

<i>Region</i>	Class Rooms	Workshops	Hand Crafts	Laboratories
<i>Tigray</i>	79	1		11
<i>Afar</i>	20			
<i>Amhara</i>	146	9	5	18
<i>Oromia</i>	234	12	4	28
<i>Somale</i>	43			1
<i>Benishangool-Gumuz</i>	69	2	1	2
<i>SNNPR</i>	379	11	8	33
<i>Gambella</i>	38			3
<i>Harari</i>	43	1	1	
<i>Addis Ababa</i>	535	9	5	22
<i>Dire Dawa</i>	36	2	1	2
<i>Total</i>	1622	47	25	120

Government - 1994E.C.(2001/02)

<i>Region</i>	Class Rooms	Workshops	Hand Crafts	Laboratories
<i>Tigray</i>	49			7
<i>Afar</i>	20			
<i>Amhara</i>	121	5	1	13
<i>Oromia</i>	152	10	3	19
<i>Somale</i>	43			1
<i>Benishangool-Gumuz</i>	69	2	1	2
<i>SNNPR</i>	355	11	8	30
<i>Gambella</i>	38			3
<i>Harari</i>	21			
<i>Addis Ababa</i>				
<i>Dire Dawa</i>				
<i>Total</i>	868	28	13	75

Non-Government - 1994E.C.(2001/02)

<i>Region</i>	Class Rooms	Workshops	Hand Crafts	Laboratories
<i>Tigray</i>	30	1		4
<i>Afar</i>				
<i>Amhara</i>	25	4	4	5
<i>Oromia</i>	82	2	1	9
<i>Somale</i>				
<i>Benishangool-Gumuz</i>				
<i>SNNPR</i>	24			3
<i>Gambella</i>				
<i>Harari</i>	22	1	1	
<i>Addis Ababa</i>	535	9	5	22
<i>Dire Dawa</i>	36	2	1	2
<i>Total</i>	754	19	12	45

Urban - 1994E.C.(2001/02)

<i>Region</i>	Class Rooms	Workshops	Hand Crafts	Laboratories
<i>Tigray</i>	79	1		11
<i>Afar</i>	20			
<i>Amhara</i>	136	8	5	16
<i>Oromia</i>	234	12	4	28
<i>Somale</i>	43			1
<i>Benishangool-Gumuz</i>	40	1		2
<i>SNNPR</i>	309	9	8	27
<i>Gambella</i>	18			2
<i>Harari</i>	43	1	1	
<i>Addis Ababa</i>	535	9	5	22
<i>Dire Dawa</i>	36	2	1	2
<i>Total</i>	1493	43	24	111

Rural - 1994E.C.(2001/02)

<i>Region</i>	Class Rooms	Workshops	Hand Crafts	Laboratories
<i>Tigray</i>				
<i>Afar</i>				
<i>Amhara</i>	10	1		2
<i>Oromia</i>				
<i>Somale</i>				
<i>Benishangool-Gumuz</i>	29	1	1	
<i>SNNPR</i>	70	2		6
<i>Gambella</i>	20			1
<i>Harari</i>				
<i>Addis Ababa</i>				
<i>Dire Dawa</i>				
<i>Total</i>	129	4	1	9

Availability of Facilities in Schools by Region

Primary (Grade 1-4) 1994 E.C. /2001-02/

Region	No. of Schools	Number of Schools by shift					Library				
		One shift	Two shifts	Three Shifts	Combination	Total	NR	Y	N	%Y	
Tigray	374	195	145			27	367	2	44	328	11.8
Afar	90	67	7			8	82	3	18	69	20.7
Amhara	1274	859	402	1		3	1265		196	1078	15.4
Oromiya	2038	1635	339	1		7	1982		440	1598	21.6
Somali*	138	100	24				124	9	1	128	0.8
Benishangul-Gumuz	158	135	8			2	145		33	125	20.9
SNNPR	714	528	181			2	711		127	587	17.8
Gambella	85	70	10			1	81		16	69	18.8
Harari	16	7	7				14		2	14	12.5
Addis Ababa	23	20	3				23		12	11	52.2
Dire Dawa	23	19	3			1	23			23	
Total	4933	3635	1129		2	51	4817	14	889	4030	18.1

Primary (Grade 1-8) 1994 E.C. /2001-02/

Region	No. of Schools	Number of Schools by shift					Library				
		One shift	Two shifts	Three Shifts	Combination	Total	NR	Y	N	%Y	
Tigray	545	187	328			28	543	2	175	368	32.2
Afar	50	39	6			3	48	1	14	35	28.6
Amhara	1691	549	1137			2	1688		775	916	45.8
Oromiya	2538	1234	1294	2		4	2534		1187	1351	46.8
Somali*	107	50	43	5			98	6	3	98	3.0
Benishangul-Gumuz	112	101	8			3	112		41	71	36.6
SNNPR	1607	729	872	2		2	1605		636	971	39.6
Gambella	55	42	10				52	1	17	37	31.5
Harari	30	13	16				29		15	15	50.0
Addis Ababa	254	178	74			2	254		152	102	59.8
Dire Dawa	36	17	19				36		10	26	27.8
Total	7025	3139	3807		9	44	6999	10	3025	3990	43.1

Secondary (Grade 9-10) 1994 E.C. /2001-02/

Region	No. of Schools	Number of Schools by shift					Library				
		One shift	Two shifts	Three Shifts	Combination	Total	NR	Y	N	%Y	
Tigray											
Afar											
Amhara	8	4	4				8		6	2	75.0
Oromiya	25	16	9				25		21	4	84.0
Somali											
Benishangul-Gumuz											
SNNPR	6	4	2				6		6		100.0
Gambella											
Harari											
Addis Ababa	3	1	2				3		2	1	66.7
Dire Dawa	1		1				1			1	
Total	43	25	18				43		35	8	81.4

Secondary (Grade 9-12) 1994 E.C. /2001-02/

Region	No. of Schools	Number of Schools by shift					Library			
		shift	shifts	Shifts	ion	Total	NR	Y	N	%Y
Tigray	34	5	22	5	1	33	1	31	2	93.9
Afar	5	3	1			4	1	4		100.0
Amhara	67	9	52	5		66		62	5	92.5
Oromiya	98	12	84	2		98		97	1	99.0
Somali*	5	3	2			5	1	1	3	25.0
Benishangul-Gumuz	7	3	3		1	7		6	1	85.7
SNNPR	47	10	37			47		46	1	97.9
Gambella	4	3	1			4		4		100.0
Harari	2		2			2		2		100.0
Addis Ababa	29	4	25			29		26	3	89.7
Dire Dawa	1		1			1		1		100.0
Total	299	52	230	12	2	296	3	280	16	94.6

All Grades (1-12) 1994 E.C. /2001-02/

Region	No. of Schools	Number of Schools by shift					Library			
		One shift	Two shifts	Three Shifts	Combination	Total	NR	Y	N	%Y
Tigray	7	2	3			2		7		100.0
Afar	2	1				1			2	
Amhara	10	2	8			10		10		100.0
Oromiya	16	6	10			16		16		100.0
Somali	5	3	1			4		1	4	20.0
Benishangul-Gumuz	5	5				5		4	1	80.0
SNNPR	31	8	23			31		30	1	96.8
Gambella	3	3				3		3		100.0
Harari	2	1	1			2		2		100.0
Addis Ababa	26	24	2			26		23	3	88.5
Dire Dawa	2	2				2		2		100.0
Total	109	57	48		2	107		98	11	89.9

Y = Available N = Not available NR = Not Reported

Availability of Facilities in Schools by Region

Primary (Grade 1-4) 1994 E.C. /2001-02/

Region	No. of Schools	Water				Latrines				Clinic				Pedagogical Centers			
		NR	Y	N	%Y	NR	Y	N	%Y	NR	Y	N	%Y	NR	Y	N	%Y
Tigray	374	3	48	323	12.9	2	181	191	48.7	2	8	364	2.2	2	108	264	29.0
Afar	90	3	21	66	24.1	3	46	41	52.9	3	2	85	2.3	3	8	79	9.2
Amhara	1274		366	908	28.7		886	388	69.5		22	1252	1.7		966	308	75.8
Oromiya	2038		1135	903	55.7		1298	740	63.7		5	2033	0.2		1299	739	63.7
Somali	138	9	9	120	7.0	9	39	90	30.2	12	2	124	1.6	9	3	126	2.3
Benishangul-Gumuz	158		45	113	28.5		97	61	61.4		4	154	2.5		106	52	67.1
SNNPR	714		192	522	26.9		555	159	77.7	2	8	704	1.1		380	334	53.2
Gambella	85		43	42	50.6		24	61	28.2		6	79	7.1		23	62	27.1
Harari	16		4	12	25.0		13	3	81.3		1	15	6.3		9	7	56.3
Addis Ababa	23		18	5	78.3		21	2	91.3		4	19	17.4		14	9	60.9
Dire Dawa	23		9	14	39.1		23		100.0			23			7	16	30.4
Total	4933	15	1890	3028	38.4	14	3183	1736	64.7	19	62	4852	1.3	14	2923	1996	59.4

Primary (Grade 1-8) 1994 E.C. /2001-02/

Region	No. of Schools	Water				Latrines				Clinic				Pedagogical Centers			
		NR	Y	N	%Y	NR	Y	N	%Y	NR	Y	N	%Y	NR	Y	N	%Y
Tigray	545	2	167	376	30.8	2	357	186	65.7	2	16	527	2.9	2	359	184	66.1
Afar	50	2	22	26	45.8	1	42	7	85.7	3	2	45	4.3	1	28	21	57.1
Amhara	1691		720	971	42.6		1381	310	81.7		20	1671	1.2		1560	131	92.3
Oromiya	2538		1641	897	64.7		1993	545	78.5		30	2508	1.2		2349	189	92.6
Somali	107	5	24	78	23.5	5	61	41	59.8	9		98		6	11	90	10.9
Benishangul-Gumuz	112		42	70	37.5		93	19	83.0		6	106	5.4		104	8	92.9
SNNPR	1607		575	1032	35.8		1418	189	88.2		50	1557	3.1		1374	233	85.5
Gambella	55	2	23	30	43.4	1	38	16	70.4	2	4	49	7.5	1	34	20	63.0
Harari	30		15	15	50.0		28	2	93.3		1	29	3.3		23	7	76.7
Addis Ababa	254		244	10	96.1		252	2	99.2		68	186	26.8		236	18	92.9
Dire Dawa	36		26	10	72.2		35	1	97.2		2	34	5.6		24	12	66.7
Total	7025	11	3499	3515	49.9	9	5698	1318	81.2	16	199	6810	2.8	10	6102	913	87.0

Secondary (Grade 9-10) 1994 E.C. /2001-02/

Region	No. of Schools	Water				Latrines				Clinic				Pedagogical Centers			
		NR	Y	N	%Y	NR	Y	N	%Y	NR	Y	N	%Y	NR	Y	N	%Y
Tigray																	
Afar																	
Amhara	8		6	2	75.0		6	2	75.0			8			6	2	75.0
Oromiya	25		17	8	68.0		18	7	72.0			25			21	4	84.0
Somali																	
Benishangul-Gumuz																	
SNNPR	6		2	4	33.3		4	2	66.7			6			5	1	83.3
Gambella																	
Harari																	
Addis Ababa	3		2	1	66.7		3		100.0			3			1	2	33.3
Dire Dawa	1	1					1		100.0			1					1
Total	43	1	27	15	64.3		32	11	74.4			43			33	10	76.7

Secondary (Grade 9-12) 1994 E.C. /2001-02/

Region	No. of Schools	Water				Latrines				Clinic				Pedagogical Centers			
		NR	Y	N	%Y	NR	Y	N	%Y	NR	Y	N	%Y	NR	Y	N	%Y
Tigray	34	1	24	9	72.7	1	24	9	72.7	1	4	29	12.1	1	16	17	48.5
Afar	5		1	4	20.0		2	3		2		3		1	2	2	50.0
Amhara	67		61	6	91.0		66	1	98.5		3	64	4.5		62	5	92.5
Oromiya	98		88	10	89.8		90	8	91.8		12	86	12.2		92	6	93.9
Somali	5	1		4		1	4		100.0	1		4		1		4	
Benishangul-Gumuz	7		5	2	71.4		6	1	85.7		1	6	14.3		6	1	85.7
SNNPR	47		37	10	78.7		41	6	87.2		3	44	6.4	-2	43	6	87.8
Gambella	4		1	3	25.0		4		100.0			4			4		100.0
Harari	2		2		100.0		2		100.0			2			2		100.0
Addis Ababa	29		29		100.0		29		100.0		17	12	58.6		23	6	79.3
Dire Dawa	1		1		100.0		1		100.0			1			1		100.0
Total	299	2	249	48	83.8	2	269	28	90.6	4	40	255	13.6	1	251	47	84.2

All Grades (1-12) 1994 E.C. /2001-02/

Region	No. of Schools	Water				Latrines				Clinic				Pedagogical Centers			
		NR	Y	N	%Y	NR	Y	N	%Y	NR	Y	N	%Y	NR	Y	N	%Y
Tigray	7		4	3	57.1		7		100.0		1	6	14.3		4	3	57.1
Afar	2		2		100.0		2		100.0			2			2		
Amhara	10		7	3	70.0		9	1	90.0			10			9	1	90.0
Oromiya	16		14	2	87.5		14	2	87.5		1	15	6.3		15	1	93.8
Somali	5			5			2	3	40.0			5			2	3	40.0
Benishangul-Gumuz	5		2	3	40.0		5		100.0			5			5		100.0
SNNPR	31		21	10	67.7		28	3	90.3		1	30	3.2		31		100.0
Gambella	3		1	2	33.3		3		100.0			3			2	1	66.7
Harari	2		2		100.0		2		100.0		1	1	50.0		2		100.0
Addis Ababa	26		25	1	96.2		26		100.0		16	10	61.5		19	7	73.1
Dire Dawa	2		2		100.0		2		100.0			2			1	1	50.0
Total	109		80	29	73.4		100	9	91.7		20	89	18.3		90	19	82.6

Y = Available N = Not available NR = Not Reported

**Primary (1-8) Flow rates (Regular)
Ethiopia 1993 E.C. (2000/2001)**

Boys	Grades								Total
	1	2	3	4	5	6	7	8	
Enrolment 93	1156703	787392	659070	541960	431696	323640	264318	182085	4346864
Enrollment 94	1151625	824644	708257	612819	492661	376087	343256	219101	4728450
Repeaters 94	119915	56128	41978	43813	30987	15072	33136	24989	366018
Readmitted 94	96590	49834	41108	32848	27435	18943	23225	9603	299586
Promotion rate	0.6213	0.7940	0.8135	0.8012	0.7924	0.8865	0.6981	0.8089	0.7534
Repetition rate	0.1037	0.0713	0.0637	0.0808	0.0718	0.0466	0.1254	0.1372	0.0842
Dropout rate	0.2750	0.1347	0.1228	0.1179	0.1358	0.0670	0.1766	0.0539	0.1624

Girls	Grades								Total
	1	2	3	4	5	6	7	8	
Enrolment 93	895904	575857	437052	329360	241584	174340	155586	117574	2927257
Enrollment 94	901510	623818	500379	402902	293397	204686	194198	133420	3254310
Repeaters 94	107163	52602	37428	38403	29472	13082	32327	25100	335577
Readmitted 94	63523	28134	20514	14349	10270	6677	8389	3969	155825
Promotion rate	0.6062	0.7683	0.8012	0.7701	0.7655	0.8804	0.6707	0.7133	0.7228
Repetition rate	0.1196	0.0913	0.0856	0.1166	0.1220	0.0750	0.2078	0.2135	0.1146
Dropout rate	0.2742	0.1403	0.1132	0.1133	0.1125	0.0446	0.1215	0.0732	0.1625

Total	Grades								Total
	1	2	3	4	5	6	7	8	
Enrolment 93	2052607	1363249	1096122	871320	673280	497980	419904	299659	7274121
Enrollment 94	2053135	1448462	1208636	1015721	786058	580773	537454	352521	7982760
Repeaters 94	227078	108730	79406	82216	60459	28154	65463	50089	701595
Readmitted 94	160113	77968	61622	47197	37705	25620	31614	13572	455411
Promotion rate	0.6147	0.7831	0.8086	0.7895	0.7827	0.8843	0.6879	0.7714	0.7411
Repetition rate	0.1106	0.0798	0.0724	0.0944	0.0898	0.0565	0.1559	0.1672	0.0965
Dropout rate	0.2747	0.1371	0.1190	0.1162	0.1275	0.0591	0.1562	0.0615	0.1624

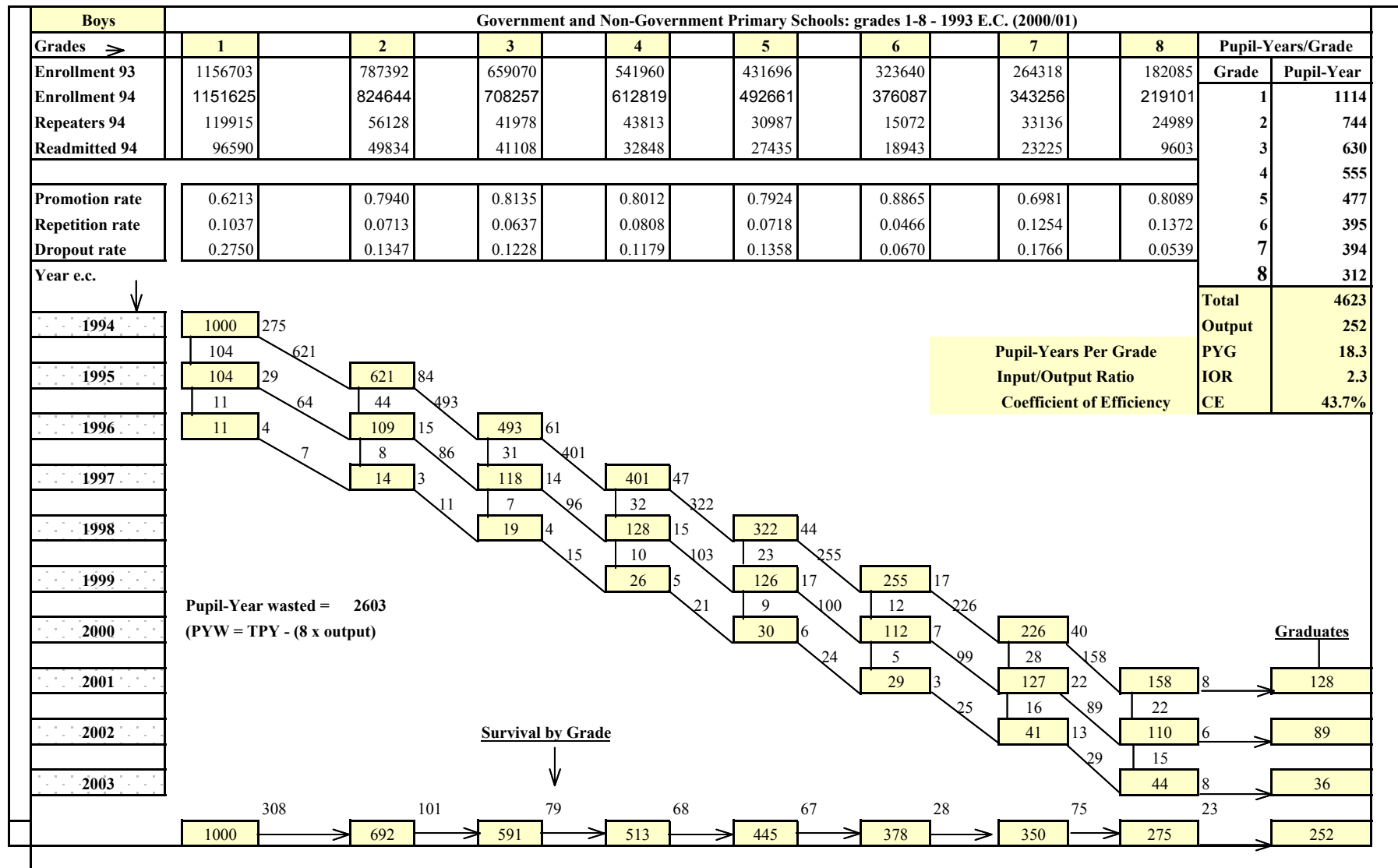

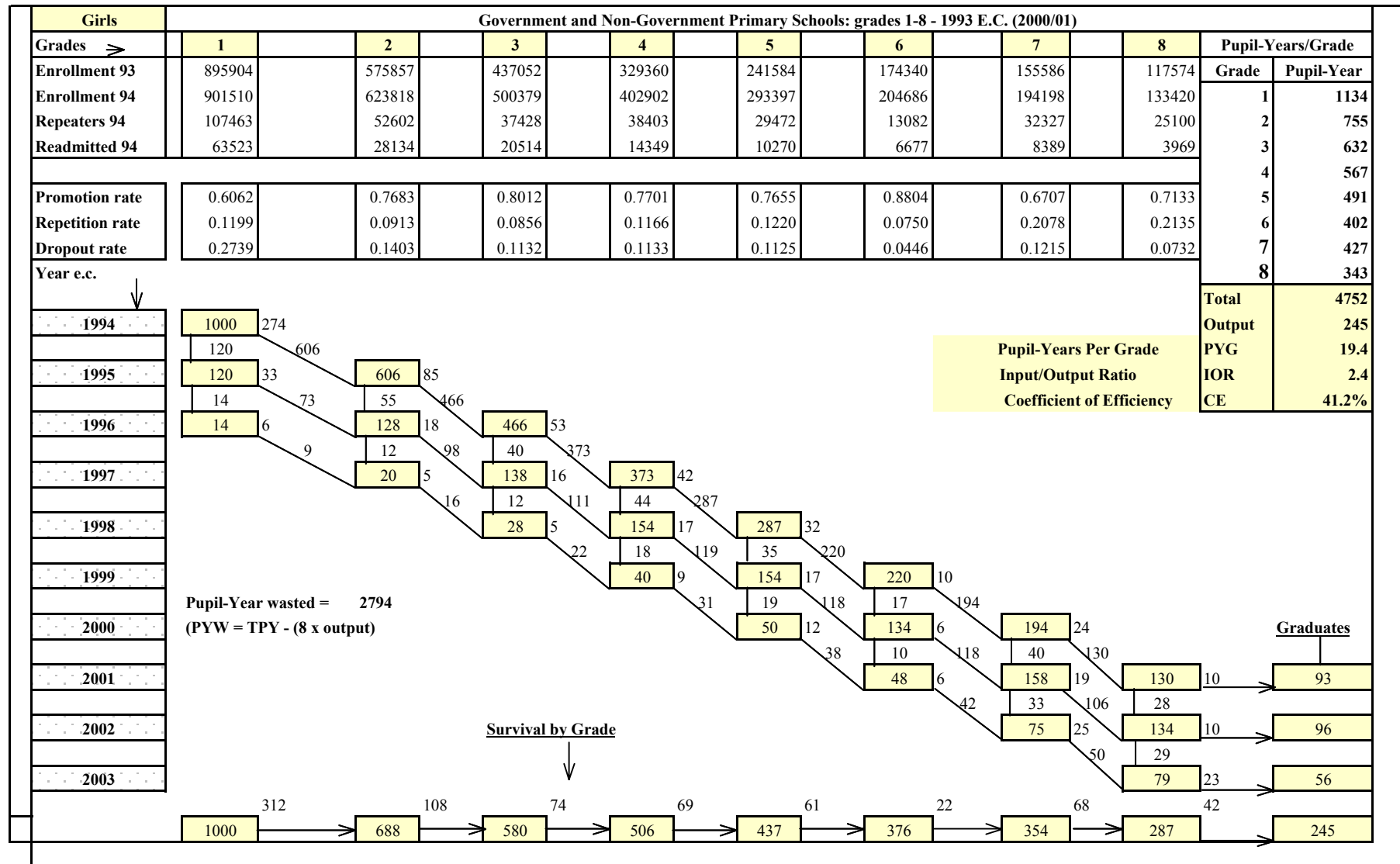

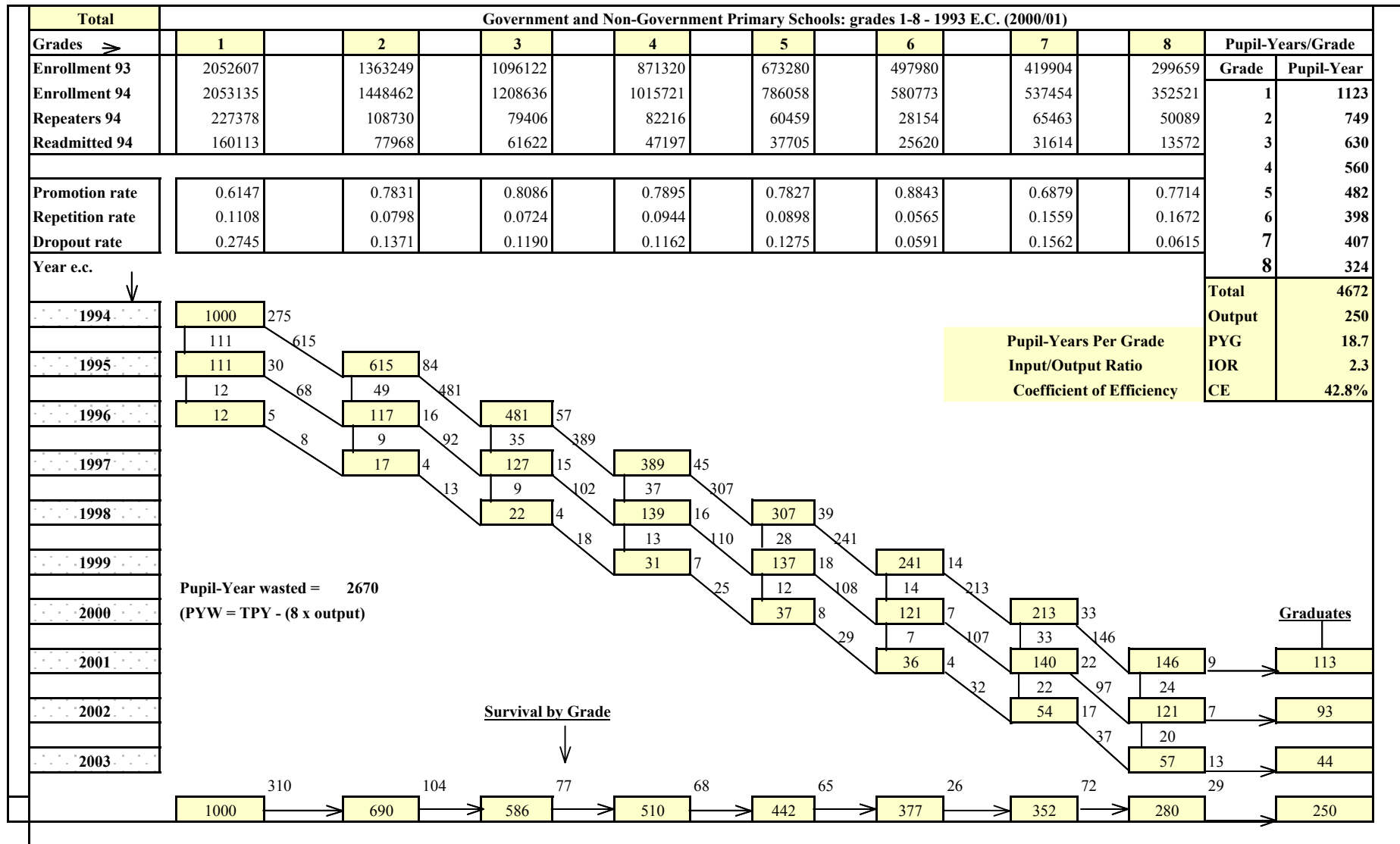

Internal Efficiency in primary grades 1-8
Government and Non Government Primary schools 1993 E.C. (2000/01)

A. PUPIL-YEARS PER GRADE

	1	2	3	4	5	6	7	8
Boys	1114	744	630	555	477	395	394	312
Girls	1134	755	632	567	491	402	427	343
Total	1123	749	630	560	482	398	407	324

B. INDICATORS OF RETENTION BY GRADE

1. Survival by grade

	1	2	3	4	5	6	7	8
Boys	692	591	513	445	378	350	275	252
Girls	688	580	506	437	376	354	287	245
Total	690	586	510	442	377	352	280	250

2. Dropouts by grade

	1	2	3	4	5	6	7	8
Boys	308	101	79	68	67	28	75	23
Girls	312	108	74	69	61	22	68	42
Total	310	104	77	68	65	26	72	29

3. Number of graduates from the final year

Boys	Girls	Total
252	245	250

C. INDICATORS OF RETENTION BY YEARS SPENT IN THE CYCLE

1. Enrolment by years of study

Year	Boys	Girls	Total
1992	1000	1000	1000
1993	725	726	725
1994	613	608	611
1995	533	532	533
1996	469	469	469
1997	406	414	409
1998	367	378	371
1999	314	336	322
2000	152	209	175
2001	44	79	57

Internal Efficiency in primary grades 1-8
Government and Non Government Primary schools 1993 E.C. (2000/01)

2. Dropouts by years of study

Year	Boys	Girls	Total
1993	275	274	275
1994	112	118	115
1995	79	76	78
1996	65	63	64
1997	62	55	60
1998	39	36	38
1999	54	41	48
2000	34	35	35
2001	18	35	24
2002	8	23	13
Total	748	755	750

3. Graduates by years of study

Year	Boys	Girls	Total
2000	128	93	113
2001	89	96	93
2002	36	56	44

D. INDICATORS OF DURATION OF STUDY

1. Average duration of study for graduates

Boys	Girls	Total
8.6	8.9	8.7

2. Average duration of study for dropouts

Boys	Girls	Total
3.3	3.4	3.3

3. Average duration of study for the cohort

Boys	Girls	Total
4.6	4.8	4.7

Internal Efficiency in primary grades 1-8
Government and Non Government Primary schools 1993 E.C. (2000/01)

E. INDICATORS OF WASTAGE IN EDUCATION

1. Input/output ratio

Boys	Girls	Total
2.3	2.4	2.3

Coefficient of Efficiency

Boys	Girls	Total
43.7	41.2	42.8

2. Proportion of total wastage spent on repetition and dropout(%)

	Boys	Girls	Total
Wastage due to dropouts	85.5	81.2	83.7
Wastage due to repetition	14.5	18.8	16.3

3. Proportion of total wastage spent on graduates(%)

	Boys	Girls	Total
Wastage due to graduates repeating grades	9.7	8.8	9.4
Wastage due to dropouts	90.3	91.2	90.6

F. BRIEF SUMMARY

	Boys	Girls	Total
Total Pupil-Years	4623	4752	4672
Output	252	245	250
Pupil-years per graduates	18.3	19.4	18.7
Pupii-years wasted	2603	2794	2670
Input-output ratio	2.3	2.4	2.3
Coefficient of Efficiency	43.7	41.2	42.8

Teacher Training Institutions Enrollment, Graduates and Teachers - 1994 E.C.

TTI	Regular Programme						Evening Programme						Kiremt (Inservice) Programme								
	Students Registered			Graduates			Students Registered			Graduates			Students Registered			Graduates			Treachers		
	Male	Female	Total	Male	Female	Total	Male	Female	Total	Male	Female	Total	Male	Female	Total	Male	Female	Total	Male	Female	Total
Adwa	363	187	550	362	186	548	414	136	550	414	136	550	153	264	417				21	1	22
Arba Minch	379	226	605	378	222	600													19	1	20
Bonga	376	221	597	376	212	588							216	73	289	216	73	289	19	1	20
Hosana	245	173	418	245	173	418													19	1	20
Assela	178	149	327	175	148	323	586	95	681										27	3	30
Debre Berhan	271	352	623	270	347	617													29	2	31
Dessie	266	334	600	266	330	596													26	1	27
Gambella	164	48	212	164	43	207													39	3	42
Harar	119	68	187	119	68	187	128	244	372	128	244	372							15	1	16
Metu	288	261	549	285	254	539													24	1	25
Nekemte	312	287	599	312	287	599	294	127	421										26		26
Jijiga	248	17	265																19		19
Robie	294	254	548	291	256	547	492	148	640										25		25
Grand Total	3503	2577	6080	3243	2526	5769	1914	750	2664	542	380	922	369	337	706	216	73	289	308	15	323

Enrollment in Technical & Vocational Education & Training Institutions

Regular Program

Government and Non-Government

Region	No. of TVET centers	1Year (10+1)		2 Year(10+2)				3Year		Total		
		Male	Female	First Year		Second Year		Male	Female	Male	Female	Both
				Male	Female	Male	Female					
Tigray	18	2026	886	36	3			37	11	2099	900	2999
Afar	2	55	30	93	74					148	104	252
Amhara	20	1321	2065	1197	1496	160	92			2678	3653	6331
Oromiya	39	3619	2401	428	75			90	15	4137	2491	6628
Somali	2	124	79	79	25					203	104	307
Benshangul-Gumuz	2	118	82							118	82	200
SNNPR	37	1802	1217	435	208					2237	1425	3662
Gambella	1	69	14							69	14	83
Harari	1	77	99							77	99	176
Addis Ababa	17	3296	4292	4970	4539					8266	8831	17097
Dire Dawa	2	157	209	54	21					211	230	441
Total	141	12664	11374	7292	6441	160	92	127	26	20243	17933	38176

Government

Region	No. of TVET centers	1Year (10+1)		2 Year(10+2)				3Year		Total		
		Male	Female	First Year		Second Year		Male	Female	Male	Female	Both
				Male	Female	Male	Female					
Tigray	11	1776	646							1776	646	2422
Afar	2	55	30	93	74					148	104	252
Amhara	20	1321	2065	1197	1496	160	92			2678	3653	6331
Oromiya	37	3568	2343	428	75			90	15	4086	2433	6519
Somali	2	124	79	79	25					203	104	307
Benshangul-Gumuz	2	118	82							118	82	200
SNNPR	35	1767	1212	435	208					2202	1420	3622
Gambella	1	69	14							69	14	83
Harari	1	77	99							77	99	176
Addis Ababa	10	2809	4214	4659	4427					7468	8641	16109
Dire Dawa	2	157	209	54	21					211	230	441
Total	123	11841	10993	6945	6326	160	92	90	15	19036	17426	36462

Non-Government

Region	No. of TVET centers	1Year (10+1)		2 Year(10+2)				3Year		Total		
		Male	Female	First Year		Second Year		Male	Female	Male	Female	Sum
				Male	Female	Male	Female					
Tigray	7	250	240	36	3			37	11	323	254	577
Oromiya	2	51	58							51	58	109
SNNPR	2	35	5							35	5	40
Addis Ababa	7	487	78	311	112					798	190	988
Total	18	823	381	347	115			37	11	1207	507	1714

Technical & Vocational Education & Training Teachers

Government and Non-Government

Region	Sex	Ethiopian									Expatriates				Total (Eth. & Exp.)		
		Less than Diploma	12 + 2	12 + 3	Diploma	B.A/ B.Sc	M.A/ M.Sc	Others	Not Reported	Total	Diploma	B.A/ B.Sc	M.A M.Sc	Total	Male	Female	Both
		Tigray	<i>M</i>			2	68	7				77			3	3	80
	<i>F</i>				29	1				30							
Afar	<i>M</i>				20	19				39			2	2	41		41
	<i>F</i>																
Amhara	<i>M</i>	4		10	342	41	2		2	401		7		7	408	84	492
	<i>F</i>	2		1	78	1			2	84							
Oromiya	<i>M</i>	8		15	338	63	7	9		440		1	7	8	448	109	557
	<i>F</i>	1			104	2		2		109							
Somali	<i>M</i>			4	21	4				29					29	1	30
	<i>F</i>				1					1							
Benshangul-Gumuz	<i>M</i>									19					19	4	23
	<i>F</i>									4							
SNNPR	<i>M</i>			17	82	23	1			123		3		3	138	12	150
	<i>F</i>				10	2				12							
Gambella	<i>M</i>				8	1				9			2	2	11	2	13
	<i>F</i>				2					2							
Harari	<i>M</i>			18		4				22					22	5	27
	<i>F</i>	1	2	2						5							
Addis Ababa	<i>M</i>	1	34	45	226	181	7	8		502	1		1	2	504	216	720
	<i>F</i>		50	4	138	23				215		1		1			
Dire Dawa	<i>M</i>		7	4	17	14	4			46					46	5	51
	<i>F</i>		4			1				5							
<i>Total</i>	<i>M</i>	13	41	115	1122	357	21	17	2	1707	1	11	15	27	1,746	468	2,214
	<i>F</i>	4	56	7	362	30		2	2	467		1		1			

Technical & Vocational Education & Training Teachers

Government

Region	Sex	Ethiopian									Expatriates				Total (Eth. & Exp.)		
		Less than Diploma	12 + 2	12 + 3	Diploma	B.A/ B.Sc	M.A/ M.Sc	Others	Not Reported	Total	Diploma	B.A/ B.Sc	M.A M.Sc	Total	Male	Female	Both
Tigray	M			1	45	1				47			1	1	48	27	75
	F				27					27							
Afar	M				20	19				39			2	2	41		41
	F																
Amhara	M	4		10	342	41	2		2	401		7		7	408	84	492
	F	2		1	78	1			2	84							
Oromiya	M	8		15	336	60	7	9		435		1	7	8	443	102	545
	F	1			98	1		2		102							
Somali	M			4	21	4				29					29	1	30
	F				1					1							
Benshangul-Gumuz	M									19					19	4	23
	F									4							
SNNPR	M			17	82	23	1			123		3		3	126	12	138
	F				10	2				12							
Gambella	M				8	1				9			2	2	11	2	13
	F				2					2							
Harari	M			18		4				22					22	5	27
	F	1	2	2						5							
Addis Ababa	M	1	32	41	167	147	3	1		392					392	201	593
	F		49	3	130	19				201							
Dire Dawa	M		7	4	17	14	4			46					46	5	51
	F		4		1	1				5							
<i>Total</i>	M	13	39	110	1038	314	17	10	2	1562		11	12	23	1,585	443	2,028
	F	4	55	6	346	24		2	2	443							

Non-Government

Region	Sex	Ethiopian									Expatriates				Total (Eth. & Exp.)		
		Less than Diploma	12 + 2	12 + 3	Diploma	B.A/ B.Sc	M.A/ M.Sc	Others	Not Reported	Total	Diploma	B.A/ B.Sc	M.A M.Sc	Total	Male	Female	Both
Tigray	M			1	23	6				30			2	2	32	3	35
	F				2	1				3							
Oromiya	M				2	3				5					5	7	12
	F				6	1				7							
SNNPR	M														12		12
	F																
Addis Ababa	M		2	4	59	34	4	7		110	1		1	2	112	15	127
	F		1	1	8	4				14		1		1			
<i>Total</i>	M		2	5	84	43	4	7		145	1		3	4	161	25	186
	F		1	1	16	6				24		1		1			

Technical and vocational Education and Training Enrollment by Field of Specialization

National

Government and Non-Government

Occupation Title	1 Year		2 Year				3 Year		Total		
	Male	Female	First Year		Second Year		Male	Female	Male	Female	Both
			Male	Female	Male	Female					
Accountant	2320	1901	472	1012	39	14			2831	2927	5758
Secretary	658	1897	36	975					694	2872	3566
Bank and Insurance Operator	365	727	198	533	4	11			567	1271	1838
Purchaser	467	428	194	365					661	793	1454
Sales Person	481	567	161	444					642	1011	1653
Information Technology Technician	340	516	190	260					530	776	1306
Hotel Service Person	103	275	11	105		15			114	395	509
House Manager	6	221	1	21					7	242	249
Cook	102	406	18	252		4			120	662	782
Bakery and Confectionery Maker	131	356	9	45					140	401	541
Hair Dresser	53	257	7	182					60	439	499
Building Construction Technician	772	302	626	169	23		32	13	1453	484	1937
Road Construction Technician	179	134	236	71					415	205	620
Surveyor	342	334	373	209	8				723	543	1266
Wood Worker	529	198	450	123	10	2	8	1	997	324	1321
Drafter	375	374	317	346	4	9			696	729	1425
General Mechanic	1427	312	1000	165	13		38	5	2478	482	2960
Machinist	300	147	295	111	8				603	258	861
Auto Mechanic	1696	173	1185	160	23		19		2923	333	3256
Electrician	1023	459	877	303	8	26	20	2	1928	790	2718
Electronics Technician	498	309	521	178	13	11	10	5	1042	503	1545
Dress Maker	156	517	9	117	7				172	634	806
Tailor	232	227	44	87					276	314	590
Textile Craft Person	72	317	62	208					134	525	659
Fine Arts	17	8							17	8	25
Music	19	6							19	6	25
Leather work	1	6							1	6	7
Total	12664	11374	7292	6441	160	92	127	26	20243	17933	38176

Non-Government

Occupation Title	1 Year		2 Year				3 Year		Total		
	Male	Female	First Year		Second Year		Male	Female	Male	Female	Both
			Male	Female	Male	Female					
Accountant	51	75	1	38					52	113	165
Secretary	15	59		43					15	102	117
Information Technology Technician	30	33	5	4					35	37	72
Hotel Service Person		32								32	32
Hair Dresser		9								9	9
Building Construction Technician	17	1	25	1			20	8	62	10	72
Wood Worker			29	2					29	2	31
Drafter	4	3	17	5					21	8	29
General Mechanic	156	32	123	7			17	3	296	42	338
Machinist	9	4	16	4					25	8	33
Auto Mechanic	340	7	99	4					439	11	450
Electrician	68		20	7					88	7	95
Electronics Technician	86	10	12						98	10	108
Dress Maker	10	96							10	96	106
Fine Arts	17	8							17	8	25
Music	19	6							19	6	25
Leather work	1	6							1	6	7
Total	823	381	347	115			37	11	1207	507	1714

Technical and vocational Education and Training Enrollment by Field of Specialization

Region:- Tigray

Government and Non-Government

Occupation Title	1 Year		2 Year				3 Year		Total		
	Male	Female	First Year		Second Year		Male	Female	Male	Female	Both
Accountant	822	272							822	272	1094
Secretary	178	204							178	204	382
Information Technology Technician	14	21							14	21	35
Hotel Service Person	30	15							30	15	45
Cook	47	35							47	35	82
Bakery and Confectionery Maker	21	13							21	13	34
Building Construction Technician	59	44					20	8	79	52	131
Road Construction Technician	39	27							39	27	66
Surveyor	60	41							60	41	101
Wood Worker	59	6							59	6	65
Drafter	20	19							20	19	39
General Mechanic	211	18					17	3	228	21	249
Machinist	130	19							130	19	149
Auto Mechanic	134	2	36	3					170	5	175
Electrician	114	32							114	32	146
Dress Maker	19	89							19	89	108
Tailor	32	9							32	9	41
Fine Arts	17	8							17	8	25
Music	19	6							19	6	25
Leather work	1	6							1	6	7
Total	2026	886	36	3			37	11	2099	900	2999

Non-Government

Occupation Title	1 Year		2 Year				3 Year		Total		
	Male	Female	First Year		Second Year		Male	Female	Male	Female	Both
Accountant	51	75							51	75	126
Secretary	15	59							15	59	74
Information Technology Technician	14	21							14	21	35
Building Construction Technician							20	8	20	8	28
General Mechanic	51						17	3	68	3	71
Auto Mechanic	37	2	36	3					73	5	78
Electrician	45								45		45
Dress Maker		63								63	63
Fine Arts	17	8							17	8	25
Music	19	6							19	6	25
Leather work	1	6							1	6	7
Total	250	240	36	3			37	11	323	254	577

Region:- Afar

Occupation Title	1 Year		2 Year				3 Year		Total		
	Male	Female	First Year		Second Year		Male	Female	Male	Female	Both
Accountant	8	7	25	17					33	24	57
Secretary		15	1	34					1	49	50
Building Construction Technician	20	6	27	9					47	15	62
General Mechanic	27	2	40	14					67	16	83
Total	55	30	93	74					148	104	252

Region:- Benishangul-Gumuz

Occupation Title	1 Year		2 Year				3 Year		Total		
	Male	Female	First Year		Second Year		Male	Female	Male	Female	Both
Accountant	32	23							32	23	55
Secretary	21	19							21	19	40
Purchaser	22	17							22	17	39
Dress Maker	12	23							12	23	35
Wood Worker	15								15		15
Auto Mechanic	16								16		16
Total	118	82							118	82	200

Technical and vocational Education and Training Enrollment by Field of Specialization

Region:- Amhara

Occupation Title	1 Year		2 Year				3 Year		Total		
	Male	Female	First Year		Second Year		Male	Female	Male	Female	Both
			Male	Female	Male	Female					
Accountant	200	293	116	205	39	14			355	512	867
Secretary	16	283	12	211					28	494	522
Bank and Insurance Operator	50	93	45	79	4	11			99	183	282
Purchaser	44	88	68	87					112	175	287
Sales Person	17	74	42	61					59	135	194
Information Technology Technician	2	5	3	5					5	10	15
Hotel Service Person	14	68	9	49		15			23	132	155
House Manager	2	80	1	21					3	101	104
Cook	4	80	1	29		4			5	113	118
Bakery and Confectionery Maker	8	82	9	45					17	127	144
Hair Dresser	1	19	1	16					2	35	37
Building Construction Technician	80	66	91	66	23				194	132	326
Road Construction Technician	19		10	20					29	20	49
Surveyor	41	46	42	47	8				91	93	184
Wood Worker	54	54	94	35	10	2			158	91	249
Drafter	56	39	39	72	4	9			99	120	219
General Mechanic	130	13	109	14	13				252	27	279
Machinist	73	55	77	56	8				158	111	269
Auto Mechanic	162	11	158	15	23				343	26	369
Electrician	159	75	129	42	8	26			296	143	439
Electronics Technician	89	83	81	56	13	11			183	150	333
Dress Maker	20	180	8	94	7				35	274	309
Tailor	57	99	27	66					84	165	249
Textile Craft Person	23	179	25	105					48	284	332
Total	1321	2065	1197	1496	160	92			2678	3653	6331

Region:- Dire Dawa

Occupation Title	1 Year		2 Year				3 Year		Total		
	Male	Female	First Year		Second Year		Male	Female	Male	Female	Both
			Male	Female	Male	Female					
Accountant	20	71	13	11					33	82	115
Secretary	1	51							1	51	52
Bank and Insurance Operator	5	41							5	41	46
Sales Person	4	16							4	16	20
Information Technology Technician	11	16	19	10					30	26	56
General Mechanic	34		22						56		56
Electrician	30	5							30	5	35
Electronics Technician	16	8							16	8	24
Total	121	208	54	21					175	229	404

Region:- Somalie

Occupation Title	1 Year		2 Year				3 Year		Total		
	Male	Female	First Year		Second Year		Male	Female	Male	Female	Both
			Male	Female	Male	Female					
Accountant	8	5	8	5					16	10	26
Secretary		16		8						24	24
Purchaser	9	10	10	4					19	14	33
Information Technology Technician	7	5	5	7					12	12	24
Building Construction Technician	20	1							20	1	21
Wood Worker	17	2							17	2	19
Drafter	7	11							7	11	18
General Mechanic	11		12						23		23
Auto Mechanic	10		10						20		20
Electronics Technician	11	1	13						24	1	25
Electrician	12	2	10	1					22	3	25
Surveyor	12	6	11						23	6	29
Dress Maker		14								14	14
Tailor		6								6	6
Total	124	79	79	25					203	104	307

Technical and vocational Education and Training Enrollment by Field of Specialization

Region:- Oromiya

Government and Non-Government

Occupation Title	1 Year		2 Year				3 Year		Total		
	Male	Female	First Year		Second Year		Male	Female	Male	Female	Both
			Male	Female	Male	Female					
Accountant	547	404	7	3					554	407	961
Secretary	179	428		4					179	432	611
Bank and Insurance Operator	209	238							209	238	447
Purchaser	252	143							252	143	395
Sales Person	340	244							340	244	584
Information Technology Technician	184	188							184	188	372
Cook	41	76							41	76	117
Bakery and Confectionery Maker	74	151							74	151	225
Hair Dresser	24	109							24	109	133
Building Construction Technician	185	9	29	4			12	5	226	18	244
Surveyor	78	28	17	7					95	35	130
Wood Worker	130	17					8	1	138	18	156
Drafter	94	27	7	5					101	32	133
General Mechanic	400	46	90	9			21	2	511	57	568
Auto Mechanic	383	20	109	6			19		511	26	537
Electrician	252	71	127	28			20	2	399	101	500
Electronics Technician	150	27	42	9			10	5	202	41	243
Dress Maker	27	107							27	107	134
Tailor	66	49							66	49	115
Textile Craft Person	4	19							4	19	23
Total	3619	2401	428	75			90	15	4137	2491	6628

Non-Government

Occupation Title	1 Year		2 Year				3 Year		Total		
	Male	Female	First Year		Second Year		Male	Female	Male	Female	Both
			Male	Female	Male	Female					
Information Technology Technician	16	12							16	12	28
General Mechanic	25	13							25	13	38
Dress Maker	10	33							10	33	43
Total	51	58							51	58	109

Region:- Gambella

Occupation Title	1 Year		2 Year				3 Year		Total		
	Male	Female	First Year		Second Year		Male	Female	Male	Female	Both
			Male	Female	Male	Female					
Accountant	23	7							23	7	30
Information Technology Technician	3	7							3	7	10
Wood Worker	13								13		13
General Mechanic	30								30		30
Total	69	14							69	14	83

Technical and vocational Education and Training Enrollment by Field of Specialization

Region:- SNNPR

Government and Non-Government

Occupation Title	1 Year		2 Year				3 Year		Total		
	Male	Female	Male	Female	Male	Female	Male	Female	Male	Female	Both
Accountant	494	249							494	249	743
Secretary	237	393							237	393	630
Bank and Insurance Operator											
Information Technology Technician	59	74							59	74	133
Hotel Service Person	30	18							30	18	48
House Manager		4								4	4
Cook	1	36							1	36	37
Bakery and Confectionery Maker	20	43							20	43	63
Hair Dresser	18	21							18	21	39
Building Construction Technician	164	45	56	23					220	68	288
Surveyor	33	22	14	18					47	40	87
Wood Worker	88	21	29	13					117	34	151
Drafter	19	4	38	50					57	54	111
General Mechanic	157	34	60	16					217	50	267
Machinist	19	13	26	26					45	39	84
Auto Mechanic	138	6	111	7					249	13	262
Electrician	119	66	64	46					183	112	295
Electronics Technician	44	30	37	9					81	39	120
Dress Maker	72	66							72	66	138
Tailor	59	21							59	21	80
Textile Craft Person	31	51							31	51	82
Total	1802	1217	435	208					2237	1425	3662

Non-Government

Occupation Title	1 Year		2 Year				3 Year		Total		
	Male	Female	Male	Female	Male	Female	Male	Female	Male	Female	Both
General Mechanic	13								13		13
Machinist	9	4							9	4	13
Auto Mechanic	13	1							13	1	14
Total	35	5							35	5	40

Region:- Harari

Occupation Title	1 Year		2 Year				3 Year		Total		
	Male	Female	Male	Female	Male	Female	Male	Female	Male	Female	Both
Accountant	8	13							8	13	21
Secretary	1	25							1	25	26
Cook		16								16	16
Building Construction Technician	6	1							6	1	7
Surveyor	9	12							9	12	21
Wood Worker	9	1							9	1	10
Drafter	6	9							6	9	15
General Mechanic	15	4							15	4	19
Auto Mechanic	15	5							15	5	20
Electrician	8	5							8	5	13
Dress Maker		8								8	8
Total	77	99							77	99	176

Technical and vocational Education and Training Enrollment by Field of Specialization

Region:- Addis Ababa

Government and Non-Government

Occupation Title	1 Year		2 Year				3 Year		Total		
	Male	Female	First Year		Second Year		Male	Female	Male	Female	Both
			Male	Female	Male	Female					
Accountant	158	557	303	771					461	1328	1789
Secretary	25	463	23	718					48	1181	1229
Bank and Insurance Operator	101	355	153	454					254	809	1063
Purchaser	140	170	116	274					256	444	700
Sales Person	120	233	119	383					239	616	855
Information Technology Technician	60	200	163	238					223	438	661
Hotel Service Person	29	174	2	56					31	230	261
House Manager	4	137							4	137	141
Cook	9	163	17	223					26	386	412
Bakery and Confectionery Maker	8	67							8	67	75
Hair Dresser	10	108	6	166					16	274	290
Building Construction Technician	242	136	450	76					692	212	904
Road Construction Technician	121	107	226	51					347	158	505
Surveyor	92	184	262	128					354	312	666
Wood Worker	157	86	327	75					484	161	645
Drafter	173	265	233	219					406	484	890
General Mechanic	412	195	667	112					1079	307	1386
Machinist	78	60	192	29					270	89	359
Auto Mechanic	802	128	761	129					1563	257	1820
Electrician	329	203	547	186					876	389	1265
Electronics Technician	188	160	348	104					536	264	800
Dress Maker	6	30	1	23					7	53	60
Tailor	18	43	17	21					35	64	99
Textile Craft Person	14	68	37	103					51	171	222
Total	3296	4292	4970	4539					8266	8831	17097

Non-Government

Occupation Title	1 Year		2 Year				3 Year		Total		
	Male	Female	First Year		Second Year		Male	Female	Male	Female	Both
			Male	Female	Male	Female					
Accountant			1	38					1	38	39
Secretary				43						43	43
Information Technology Technician			5	4					5	4	9
Hotel Service Person		32								32	32
Hair Dresser		9								9	9
Building Construction Technician	17	1	25	1					42	2	44
Wood Worker			29	2					29	2	31
Drafter	4	3	17	5					21	8	29
General Mechanic	67	19	123	7					190	26	216
Machinist			16	4					16	4	20
Auto Mechanic	290	4	63	1					353	5	358
Electrician	23		20	7					43	7	50
Electronics Technician	86	10	12						98	10	108
Total	487	78	311	112					798	190	988

STATISTICS ON HIGHER EDUCATION

Introduction

This part presents data on higher education in Ethiopia for the 2001/02 (1994E.C.) academic year.

Definition of General Concepts

Department

The smallest academic administrative unit of an institution or a faculty or a college offering major training programs or well-defined services to other departments. The FRESHMAN PROGRAM is an example of a service unit, as it exists today like in the faculty of science of Addis Ababa University.

Program

A selection of one or more courses (planned series of learning experiences) or a combination of courses, usually chosen from a syllabus with an expressed or implied aim.

Regular Program

Describes programs offered during the daytime to full-time students of institutions of higher education.

Continuing Education Programs

Describes programs offered in evening (extension) classes and programs offered during the Ethiopian Summer.

Level of Program

This is a classification of programs representing a step in educational progression.

Diploma Program

An educational program offered by institutions of higher education for duration of two to three years after completing grade 12 successfully. Completion of this program is certified by awarding a diploma.

Undergraduate Degree Program

This is a third-level educational program which is offered for duration of four to five years after completing high school. Completion of this program is certified by awarding a Bachelor's Degree. The degree of Doctor of Medicine (MD) and the Degree of Veterinary Medicine (DVM) are also Undergraduate Degrees, which are given after a training period of 6 years, the last one being a period of internship or externship.

Postgraduate Program

This is a training, or specialization program offered under the schools of graduate studies of Addis Ababa University, Alemaya University and Debu University to students who already have their first degree. Completion of this Program is certified by awarding either a Masters Degree, Certificate in Medicine, and Ph.D. degree in very few institutions.

Time Reference

All data represent figures on higher education for first semester of the 2001/02 (1994E.C.) Academic Year. All data for the first semester of 2000/01 academic year were collected from the beginning of the first semester up to the end of the same semester.

Academic Year

The Academic Year for all Ethiopian Institutions of Higher Education commences about the end of September and ends about July of the next Year.

INSTITUTIONS OF HIGHER EDUCATION IN ETHIOPIA
YEAR OF ESTABLISHMENT, LOCATION, AND PROGRAMMES OFFERED

Government

NO	NAME OF INSTITUTION	Year Established (E.C.)	Year Reorganized (E.C)	Location	Distance from Addis Ababa (Km)	Program Level Offered			P.O.Box	Tel.	FAX
						Diploma	Undergraduate Degree	Postgraduate Degree			
1	ADDIS ABABA UNIVERSITY	1950		Addis Ababa					1176	55-08-44	55-06-55
1.1	Faculty of Science	1951		Addis Ababa		X	X	X	1176		
1.2	Institute of Language Studies	1971		Addis Ababa		X	X	X	1176	11/17/1935	
1.3	College of Social Science	1971	1983	Addis Ababa			X	X	1176	11-65-35	
1.4	Faculty of Business and Economics	1956	1983	Addis Ababa		X	X	X	5563	55-34-30	00251 (1) 55-06-55
1.5	Faculty of Technology	1945	1951,1954 & 1961	Addis Ababa		X	X	X	385	55-10-22	55-26-01
1.6	School of Pharmacy	1954	1971	Addis Ababa			X		1176	11-47-44	00251 (1) 55-09-11
1.7	Faculty of Education	1962		Addis Ababa		X	X	X	1176		
1.8	Faculty of Law	1956		Addis Ababa		X	X		1176	11-17-33 & 11-65-69	
1.9	Faculty of Veterinary Medicine	1972	1982	Oromiya	45	X	X	X	34	33-85-33 & 33-95-60	251 (1) 33-99-33
1.10	Faculty of Medicine	1964		Addis Ababa			X	X	9086	15-61-46 & 51-89-99	51-30-99
1.11	Institute of Development Research			Addis Ababa				X			
1.12	Library Science Department	1967		Addis Ababa		X	X	X	1176		
1.13	School of Medical Laboratory Technology	1947		Addis Ababa		X			5654	75-34-70	75-47-44
1.14	School of Graduate Studies	1971		Addis Ababa					1176		
2	ALEMAYA UNIVERSITY	1943	1977	Oromiya	510				138 & 38	(05)11-23-64 & 11-13-99	05-11-40-08
2.1	School of Graduate Studies			Oromiya							
2.2	Faculty of Agriculture			Oromiya			X	X			
2.3	Faculty of Health			Oromiya							
2.4	Faculty of Education			Oromiya			X	X			
3	DEBUB UNIVERSITY	1992		SNNPR						20-06-53/20-02-21	20-54-21
3.1	AWASSA COLLEGE OF AGRICULTURE	1969	1987	SNNPR	275	X	X		5	(06)200313, 200221, 200653	06-20-00-72
3.2	DILLA COLLEGE OF TEACHER EDU. & HEALTH SC.	1989		SNNPR		X	X			(06)31-01-92	
3.3	WONDO GENET COLLEGE OF FORESTRY	1970		SNNPR	263	X	X		128	(06)10-11-45; 20-15-79; 20-14-90	06-20-14-90
4	JIMMA UNIVERSITY	1992		Oromiya					378	11-14-58/60	11-14-50/11-20-40
4.1	JIMMA COLLEGE OF AGRICULTURE	1945	1960,1970 & 1980	Oromiya	335	X			307	11-01-02 & 11-00-19	C/O (251) (07) (11-05-75)
4.2	JIMMA INSTITUTE OF HEALTH SCIENCE	1975		Oromiya	335	X	X		378	(07)11-14-58, 59, 60	11-14-50
5	BAHIR DAR UNIVERSITY	1992		Amhara					79	20-01-43/20-07-60	20-20-25
5.1	BAHIR DAR POLYTECHNIC INSTITUTE	1956	1957,1962,1977 & 1989	Amhara	580	X	X		26	(08)20-02-77 & 20-01-13	C/O (08)20-07-18
5.2	BAHIR DAR TEACHERS COLLEGE	1965		Amhara	580	X	X		79	20-01-43	
6	MEKELE UNIVERSITY	1992		Tigray							
6.1	MAKELE UNIVERSITY COLLEGE	1986		Tigray	783	X	X		231	(03)40-05-12	(251)-03-40-09-83
6.2	MAKELE BUSINESS COLLEGE	1984		Tigray	777	X	X		451	(03)40-04-28 & 40-01-44	
7	GONDER COLLEGE OF MEDICAL SCIENCE	1947	1961 & 1976	Amhara	750	X	X		196	(08)11-01-74	(08) 11-14-79
8	AMBO COLLEGE OF AGRICULTURE	1939	1960	Oromiya	125	X			19	36-00-59; 36-00-07; 36-00-96	
9	ADDIS ABABA COLLEGE OF COMMERCE	1935	1949,1971 & 1984	Addis Ababa		X			3131	15-37-11/51-80-20	251-1-51-57-86
10	ARBA MINCH WATER TECHNOLOGY INST.	1979		SNNPR	500	X	X		21	81-00-70/81-07-71	251-6-810534
11	ETHIOPIA CIVIL SERVICE COLLEGE	1987		Addis Ababa		X	X		5648	46-30-06/46-30-12	(251) 46-30-16
12	NAZARETH TECHNICAL COLLEGE	1986		Oromiya	100	X	X		1888	(02)11-04-00	(251)-2-11-04-80
13	KOTEBE COLLEGE OF TEACHER EDUCATION	1962	1982	Addis Ababa		X	X		31248	60-09-21/60-14-07	(251)-1-60-09-22
14	JIMMA COLLEGE OF TEACHER EDUCATION	1989		Oromiya	335	X			95	81-00-97	
15	AWASSA COLLEGE OF TEACHER EDUCATION	1989		SNNPR	275	X			115	06 - 20-02-61	
16	GONDAR COLLEGE OF TEACHER EDUCATION	1989		Amhara	750	X			176	08 - 11-06-72/11-17-82	11-20-10
17	ABYI ADIY COLLEGE OF TEACHER EDUCATION	1989		Tigray	878	X			19	03 - 40-04-54	
18	TIGRAY ARTS COLLEGE			Tigray					605	40-77-34(35)	
19	ETHIOPIA MASS MEDIA TRAINING INSTITUTE			Addis Ababa					5646	11-29-21/11-29-05	55-22-63
20	MAICHEW Technical college			Tigray					29	(04)77-06-50	

SNNPR = Southern Nations Nationalities and People's Region

Summary of Student Enrollment 2001/02 (1994 E.C.) Academic Year - First Semester

INSTITUTION	Regular								Evening						Kiremt					
	Diploma		Undergraduate Degree		Postgraduate Degree		TOTAL		Diploma		Undergraduate Degree		TOTAL		Diploma		Undergraduate Degree		TOTAL	
	BS	F	BS	F	BS	F	BS	F	BS	F	BS	F	BS	F	BS	F	BS	F	BS	F
Government																				
ADDIS ABABA UNIVERSITY	895	212	4,342	870	1,166	94	6,403	1,176	3,320	874	4,964	1,444	8,284	2,318	1		445	79	446	79
DEBUB UNIVERSITY	801	206	3,010	501	28	1	3,839	708	552	163	863	96	1,415	259	255	89	1278	80	1,533	169
ALEMAYA UNIVERSITY	289	78	2,435	405	153	4	2,877	487	1814	469			1,814	469	903	93	940	45	1,843	138
BAHIRDAR UNIVERSITY	344	60	2,764	312			3,108	372	5942	1417	156	19	6,098	1,436	24	1	1174	59	1,198	60
JIMMA UNIVERSITY	833	191	2,887	455			3,720	646	1418	377	211	24	1,629	401						
MEKELE UNIVERSITY	348	95	2,443	385			2,791	480	2223	674	1112	223	3,335	897			431	40	431	40
GONDER COLLEGE OF MEDICAL SC.	804	236	407	62			1,211	298	522	198			522	198						
AMBO COLLEGE OF AGRICULTURE	777	137					777	137	570	111			570	111						
ADDIS ABABA COLLEGE OF COMMERCE	1,871	569					1,871	569	3609	1047			3,609	1,047						
KOTEBE COLLEGE OF TEACHER EDU.	958	349	164	18			1,122	367	2478	574	366	50	2,844	624	861	144	115		976	144
ABIY ADDI COLLEGE OF TEACHER EDUCATION	180	27					180	27	893				893							
AWASSA COLLEGE OF TEACHER EDUCATION	947	202					947	202	2615	562			2,615	562	1220	182			1,220	182
GONDAR COLLEGE OF TEACHER EDUCATION	784	220					784	220	1329	415			1,329	415	787	153			787	153
JIMMA COLLEGE OF TEACHER EDUCATION	585	257					585	257	1006	173			1,006	173	383	61			383	61
ARBA MINCH WATER TECHNOLOGY INST.	179	3	1,375	32			1,554	35	258	17			258	17						
ETHIOPIAN CIVIL SERVICE COLLEGE	323	46	1,182	84			1,505	130	485	77			485	77						
NAZARETH TECHNICAL COLLEGE	181	9	667	199			848	208	1048	234	43		1,091	234			302	4	302	4
DEFENCE ENGINEERING COLLEGE	396	7	480	3			876	10												
ETHIOPIAN MASS MEDIA TRAINING INSTITUTE	193	41					193	41	150	48			150	48						
TIGRAY ARTS COLLEGE	79	17					79	17												
MAICHEW TECHNICAL COLLEGE	254	27					254	27	148	22			148	22						
Total	12,021	2,989	22,156	3,326	1,347	99	35,524	6,414	30,380	7,452	7,715	1,856	38,095	9,308	4,434	723	4,685	307	9,119	1,030
Non-Government	12,619	7202					12,619	7,202	6472	2944			6,472	2,944						
Government and Non-Government	24,640	10,191	22,156	3,326	1,347	99	48,143	13,616	36,852	10,396	7,715	1,856	44,567	12,252	4,434	723	4,685	307	9,119	1,030

Summary of Graduates 2001/02 (1994 E.C.) Academic Year

INSTITUTION	Regular						Evening						Kiremt							
	Diploma		Undergraduate Degree		Postgraduate Degree		TOTAL		Diploma		Undergraduate Degree		TOTAL		Diploma		Undergraduate Degree		TOTAL	
	BS	F	BS	F	BS	F	BS	F	BS	F	BS	F	BS	F	BS	F	BS	F	BS	F
Government																				
ADDIS ABABA UNIVERSITY	269	64	548	100	397	30	1,214	194	489	120	328	71	817	191			41	1	41	1
DEBUB UNIVERSITY	286	53	463	43			749	96	83	9			83	9	33	1			33	1
ALEMAYA UNIVERSITY	107	31	530	52	47	3	684	86	201	42			201	42						
BAHIRDAR UNIVERSITY	88	17	438	29			526	46	1026	201	50	3	1,076	204						
JIMMA UNIVERSITY	311	58	376	55			687	113	219	53			219	53						
MEKELE UNIVERSITY	113	39	351	37			464	76	162	58			162	58			50	5	50	5
GONDER COLLEGE OF MEDICAL SC.	221	74	95	11			316	85												
AMBO COLLEGE OF AGRICULTURE	320	22					320	22	164	28			164	28						
ADDIS ABABA COLLEGE OF COMMERCE	639	156					639	156	552	158			552	158						
KOTEBE COLLEGE OF TEACHER EDU.	399	132	17				416	132	478	88	190	37	668	125	255	42	6		261	42
ABIY ADDI COLLEGE OF TEACHER EDUCATION	483	53					483	53												
AWASSA COLLEGE OF TEACHER EDUCATION	355	46					355	46	354	80			354	80						
GONDAR COLLEGE OF TEACHER EDUCATION	292	55					292	55	196	39			196	39						
JIMMA COLLEGE OF TEACHER EDUCATION	329	115					329	115	160	24			160	24						
ARBA MINCH WATER TECHNOLOGY INST.	32		133	5			165	5	53	3			53	3			24		24	
ETHIOPIAN CIVIL SERVICE COLLEGE	161	13	216	17			377	30	98	18			98	18						
NAZARETH TECHNICAL COLLEGE	131	2	114	1			245	3	231	61	42		273	61			24		24	
DEFENCE ENGINEERING COLLEGE	92	3	68				160	3												
ETHIOPIAN MASS MEDIA TRAINING INSTITUTE	96	20					96	20												
MAICHEW TECHNICAL COLLEGE	69	9					69	9												
Total	4,793	962	3,349	350	444	33	8,586	1,345	4,466	982	610	111	5,076	1,093	288	43	145	6	433	49
Non-Government	3331	1413					3,331	1,413	949	474			949	474						
Government and Non-Government	8,124	2,375	3,349	350	444	33	11,917	2,758	5,415	1,456	610	111	6,025	1,567	288	43	145	6	433	49

SUMMARY OF TEACHING STAFF IN REGULAR PROGRAMMES -2001/02 (1994 E.C.)

Institution	ETHIOPIAN		EXPATRATE		TOTAL		% Fem.	% Expatriate
	BS	F	BS	F	BS	F		
Government								
ADDIS ABABA UNIVERSITY	837	82	42	1	879	83	9.4	4.8
DEBUB UNIVERSITY	231	18	15	6	246	24	9.8	6.1
ALEMAYA UNIVERSITY	140	10	22		162	10	6.2	13.6
BAHIRDAR UNIVERSITY	164	3	6		170	3	1.8	3.5
JIMMA UNIVERSITY	272	13	21	2	293	15	5.1	7.2
MEKELE UNIVERSITY	146	10	10		156	10	6.4	6.4
GONDER COLLEGE OF MEDICAL SC.*	99	7	5	3	104	10	9.6	4.8
AMBO COLLEGE OF AGRICULTURE	45	4			45	4	8.9	
ADDIS ABABA COLLEGE OF COMMERCE	75	11			75	11	14.7	
KOTEBE COLLEGE OF TEACHER EDU.	89	4			89	4	4.5	
ABBIYI ADDI COLLEGE OF TEACHER EDUCATION	44	2	1	1	45	3	6.7	2.2
AWASSA COLLEGE OF TEACHER EDUCATION	57	2	2	1	59	3	5.1	3.4
GONDAR COLLEGE OF TEACHER EDUCATION	41		2	1	43	1	2.3	4.7
JIMMA COLLEGE OF TEACHER EDUCATION	49				49			
ARBA MINCH WATER TECHNOLOGY INST.	59	1	11		70	1	1.4	15.7
ETHIOPIAN CIVIL SERVICE COLLEGE	157	14	11	3	168	17	10.1	6.5
NAZARETH TECHNICAL COLLEGE	110	5			110	5	4.5	
DEFENCE ENGINEERING COLLEGE	57	4			57	4	7.0	
ETHIOPIAN MASS MEDIA TRAINING INSTITUTE	22	9			22	9	40.9	
TIGRAY ARTS COLLEGE	18		1		19			5.3
MAICHEW TECHNICAL COLLEGE	30		1		31			3.2
Total	2,742	199	150	18	2,892	217	7.5	5.2
Non-Government								
	408	29	13	4	421	33	7.8	3.1
Government + Non-government	3,150	228	163	22	3,313	250	7.5	4.9

* 1993 E.C. Data

STUDENT ENROLLMENT

Definition of Concepts

The information on students enrollment consists of new admissions, readmissions and students continuing from the previous semester.

Student Enrollment

Total number of students registered in a given semester.

Year of Study

This refers to the freshman year, the sophomore year, the junior year and the senior year in a four-year college programme. In Medical and Engineering departments, a year also exists. A sixth-year in medicine, is a period of internship.

Freshman Programme

A preparatory programme designed for freshman students to prepare them for admission into specific programmes of study.

**Students Enrolled in Regular Diploma Programmes by Institution, Department,
Year of Study and Sex**

2001/02 (1994 E.C.) Academic Year - First Semester

University/Institute/College/Faculty Department	Year I		Year II		Year III		Total	
	BS	F	BS	F	BS	F	BS	F
ADDIS ABABA COLLEGE OF COMMERCE	990	331	881	238			1871	569
Addis Ababa College of Commerce	990	331	881	238			1871	569
<i>Accounting</i>	383	77	403	52			786	129
<i>Banking and Finance</i>	165	25	114	10			279	35
<i>Marketing Management</i>	121	49	82	30			203	79
<i>Personnel Management</i>	41	10	47	10			88	20
<i>Purchasing and Supply Mgt.</i>	94	28	94	21			188	49
<i>Secretarial Science & Office Mgt. (Bi-Lingual)</i>	123	123	94	94			217	217
<i>Secretarial Science & Office Mgt. (Tri-Lingual)</i>	8	8	12	12			20	20
<i>Business Information System</i>	55	11	35	9			90	20
ADDIS ABABA UNIVERSITY	573	156	309	56	13		895	212
Faculty of Education	69	1	60	1			129	2
<i>Business Education</i>			1				1	
<i>Educational Administration</i>	69	1	59	1			128	2
Faculty of Technology	98		4		13		115	
<i>Building Technology</i>	98		4		13		115	
Faculty of Veterinary Medicine	98	28	68	5			166	33
<i>Animal Science</i>	98	28	68	5			166	33
Information Sciences (SISA)			7	2			7	2
<i>Library Science</i>			7	2			7	2
Faculty of Medicine	308	127	170	48			478	175
<i>Midwives</i>			20	7			20	7
<i>Anaesthesia</i>								
<i>Nursing</i>	177	111	93	33			270	144
<i>Radiography</i>	30	1					30	1
<i>Nursing(upgrading)</i>	29	12					29	12
<i>School of Medical Laboratory Technology</i>	72	3	57	8			129	11
DEBUB UNIVERSITY	491	135	310	71			801	206
Awassa College of Agriculture	175	47	99	21			274	68
<i>Basic Science</i>	175	47					175	47
<i>General Agriculture</i>			31				31	
<i>Agricultural Engineering & Mechanization</i>			37	4			37	4
<i>RDFS</i>			31	17			31	17
Wondo Genet College of Forestry	148	38	78	6			226	44
<i>Forestry</i>	148	38	78	6			226	44
Dilla College of Teacher Education and Health Sciences	168	50	133	44			301	94
Faculty of Health Science	168	50	133	44			301	94
<i>Environmental Health</i>	64	9	37	12			101	21
<i>Laboratory Technology</i>	45	6	44	3			89	9
<i>Public Health Nursing</i>	59	35	52	29			111	64
AMBO COLLEGE OF AGRICULTURE	445	112	332	25			777	137
<i>General Agriculture</i>	445	112	332	25			777	137
ALEMAYA UNIVERSITY	177	42	112	36			289	78
Faculty of Health	177	42	112	36			289	78
<i>Environmental health</i>	60	5	26	8			86	13
<i>Medical Laboratory Technology</i>	60	2	42	4			102	6
<i>Nursing</i>	57	35	44	24			101	59
ARBA MINCH WATER TECH. INSTITUTE	84	1	52	2	43		179	3
<i>Pre-Engeneering</i>	84	1	52	2			136	3
<i>Hydraulics Engineering</i>					20		20	
<i>Irrigation Engineering</i>					23		23	
BAHIR DAR UNIVERSITY	249	36	95	24			344	60
Bair Dar Teachers College	249	36	95	24			344	60
Faculty of Education	187	36	95	24			282	60
<i>Accounting</i>	42	11	51	7			93	18
<i>Banking and Finance</i>	28	3					28	3
<i>Mangement</i>	29	4					29	4
<i>Marketing Management</i>	30	2					30	2
<i>Law</i>	32	7					32	7
<i>Secretarial Science and Office management</i>	26	9	44	17			70	26
Faculty of Engineering	62						62	
<i>Textil Technology</i>	62						62	

University/Institute/College/Faculty Department	Year I		Year II		Year III		Total	
	BS	F	BS	F	BS	F	BS	F
ETHIOPIAN CIVIL SERVICE COLLEGE	125	27	172	16	26	3	323	46
Faculty of Business and Economics	51	22	69	13			120	35
<i>Accounting</i>	51	22	69	13			120	35
Faculty of Law	38	4	50	2			88	6
<i>Law</i>	38	4	50	2			88	6
Faculty of Technology	36	1	53	1	26	3	115	5
<i>Mancipal Engineering</i>	36	1	53	1	26	3	115	5
GONDER COLLEGE OF MEDICAL SCIENCE	579	162	225	74			804	236
<i>Public Health Nuring</i>	54	29	30	16			84	45
<i>Clinical Nursing</i>	67	42	42	25			109	67
<i>Laboratory Technology</i>	68	5	48	4			116	9
<i>Midwifery</i>	47	32	25	21			72	53
<i>Sanitary Science</i>	67	9	38	5			105	14
<i>Pharmacy</i>	59	6	42	3			101	9
<i>Accounting</i>	60	4					60	4
<i>Marketing Management</i>	59	5					59	5
<i>Business Management</i>	59	8					59	8
<i>Secretarial Science and Office Management</i>	39	22					39	22
JIMMA COLLEGE OF TEACHER EDUCATION	234	102	351	155			585	257
<i>A/Oromo</i>	30	22	53	40			83	62
<i>English</i>	30	17	53	18			83	35
<i>Amaharic</i>	15	13	35	31			50	44
<i>Geography</i>	20	5	25	16			45	21
<i>History</i>	20	16	33	18			53	34
<i>Biology</i>	21	13	28	8			49	21
<i>Chemistry</i>	21	5	43	10			64	15
<i>Physical</i>	21		21				42	
<i>Mathematics</i>	31	4	35	4			66	8
<i>ANFE</i>	25	7	25	10			50	17
JIMMA UNIVERSITY	487	123	346	68			833	191
Jimma College of agriculture	239	58	184	22			423	80
<i>General Agriculture</i>	239	58	97	12			336	70
<i>Animal Science</i>			25	7			25	7
<i>Plant Science</i>			31	2			31	2
<i>Horticulture</i>			31	1			31	1
Jimma Institute of Health Science	248	65	162	46			410	111
Faculty of Health Sciences	248	65	162	46			410	111
<i>Environmental Health</i>	66	10	34	9			100	19
<i>Clinical Nursing</i>	33	23	22	11			55	34
<i>Public Health Nuring</i>	37	20	17	11			54	31
<i>Pharmacy Technology</i>	57	7	44	12			101	19
<i>Med.Laboratory</i>	55	5	45	3			100	8
MEKELE UNIVERSITY	219	43	129	52			348	95
Mekele Business College	219	43	129	52			348	95
<i>Freshman Program</i>	219	43					219	43
<i>Accounting</i>			41	19			41	19
<i>Banking and Finance</i>			38	9			38	9
<i>Management</i>			26	7			26	7
<i>Secretarial Science & Office Mgt.</i>			24	17			24	17
TIGRAY ARTS COLLEGE	79	17					79	17
<i>Fine Arts Department</i>	27	4					27	4
<i>Music Department</i>	28	8					28	8
<i>Theatrical Arts Department</i>	24	5					24	5
NAZARETH TECHNICAL COLLEGE	11	1	170	8			181	9
<i>Automotive Technology</i>			30				30	
<i>Construction Technology</i>			28	1			28	1
<i>Electricity / Electrons</i>	11	1	30	3			41	4
<i>Manufacturing Technology</i>			25				25	
<i>Drafting</i>			28				28	
<i>Surveying</i>			29	4			29	4
DEFENCE ENGINEERING COLLEGE	206	3	98	1	92	3	396	7

University/Institute/College/Faculty Department	Year I		Year II		Year III		Total	
	BS	F	BS	F	BS	F	BS	F
ETHIOPIAN MASS MEDIA TRAINING INSTITUTE	89	16	104	25			193	41
<i>Print Media</i>	49	12	50	9			99	21
<i>Radio Section</i>	20	2	27	12			47	14
<i>Television Section</i>	20	2	27	4			47	6
MAICHEW TECHNICAL COLLEGE	113	13	69	5	72	9	254	27
<i>Freshman Program</i>	113	13					113	13
<i>Automotive Technology</i>			18		17		35	
<i>Construction Technology</i>			18	3	22	5	40	8
<i>Electrical Technology</i>			19	2	19	4	38	6
<i>Manufacturing Technology</i>			14		14		28	
ABIY ADDI COLLEGE OF TEACHER EDUCATION			180	27			180	27
<i>Tigreigna</i>			14	8			14	8
<i>Amharic</i>			10	6			10	6
<i>Mathematics</i>			23	3			23	3
<i>English</i>			25	1			25	1
<i>Physics</i>			11				11	
<i>Chemistry</i>			25	2			25	2
<i>Biology</i>			20	5			20	5
<i>History</i>			20	1			20	1
<i>Geography</i>			22	1			22	1
<i>Health and Physical Education</i>			10				10	
AWASSA COLLEGE OF TEACHER EDUCATION	540	138	407	64			947	202
<i>English</i>	92	42	53	8			145	50
<i>Amharic</i>	59	42	47	39			106	81
<i>Mathematics</i>	104	11	48	1			152	12
<i>Physics</i>	45	2	47	1			92	3
<i>Biology</i>	60	17	35	3			95	20
<i>Geography</i>	50	3	39	1			89	4
<i>History</i>	28	4	50	1			78	5
<i>Chemistry</i>	53	8	56	3			109	11
<i>Physical Education</i>	49	9	32	7			81	16
GONDAR COLLEGE OF TEACHER EDUCATION	425	139	359	81			784	220
<i>Amharic</i>	37	28	18	14			55	42
<i>English</i>	76	25	62	26			138	51
<i>Mathematics</i>	81	11	62	7			143	18
<i>Biology</i>	63	35	36	13			99	48
<i>Chemistry</i>	60	25	43	7			103	32
<i>Physics</i>	51	3	64	5			115	8
<i>Geography</i>	29	8	34	5			63	13
<i>History</i>	28	4	40	4			68	8
KOTEBE COLLEGE OF TEACHER EDUCATION	474	195	484	154			958	349
<i>English</i>	54	22	57	16			111	38
<i>Ethiopian languages and Literature</i>	52	29	47	31			99	60
<i>Geography</i>	61	22	75	19			136	41
<i>History</i>	63	29	66	12			129	41
<i>Health and Physical Education</i>	43	6	53	12			96	18
<i>Mathematics</i>	50	24	45	13			95	37
<i>Chemistry</i>	48	25	54	23			102	48
<i>Biology</i>	56	23	51	18			107	41
<i>Physics</i>	47	15	36	10			83	25
Grand Total	6590	1792	5185	1182	246	15	12021	2989

Students Enrolled and Graduates in Diploma Programmes by Institution, Department and Sex

2001/02 (1994 E.C.) Academic Year - First Semester

Non- Government Higher Institutions

University/Institute/College/Faculty Department	Regular		Evening		Total		Graduates	
	BS	F	BS	F	BS	F	BS	F
ETHIOPIAN ADVENTIST COLLEGE	117	30	73	17	190	47	51	11
<i>Accounting</i>	57	17	15	9	72	26	18	5
<i>Managemen</i>	17	3	23	2	40	5	9	1
<i>Secretarial Science</i>	2	2	1	1	3	3		
<i>Biology - Education</i>	4	2	4		8	2		
<i>English - Education</i>	6	1	11	1	17	2	6	
<i>G/Agriculture - Education</i>	3		2	1	5	1	1	
<i>Community Development and Leadership</i>	28	5	17	3	45	8	17	5
"Menshen Für Menschen" Foundation Agro-Technical Training College	290	18			290	18	95	3
<i>Agro-Ecology</i>	85	5			85	5	28	
<i>Electrical Technology</i>	71				71		17	3
<i>Auto-Mechanics</i>	62	13			62	13	22	
<i>Metal Technology</i>	72				72		28	
UNITY COLLEGE	4147	2172	2952	1515	7099	3687	1963	978
<i>Accounting</i>	3110	1518	1725	874	4835	2392	1398	653
<i>Business Administration</i>	260	147	194	91	454	238	151	50
<i>Marketing</i>	377	212	421	186	798	398	139	83
<i>Secretarial Science and Office Management</i>	235	234	310	310	545	544	180	180
<i>Law</i>	114	37	257	40	371	77	82	8
<i>Personnel management</i>			18	4	18	4		
<i>Journalism</i>	51	24	27	10	78	34	13	4
AFRICA BEZA COLLEGE	771	317	539	257	1310	574	207	77
<i>Accounting</i>	693	254	347	149	1040	403	186	74
<i>law</i>			105	24	105	24	16	3
<i>Secretarial Science and Office Management</i>	58	58	81	81	139	139		
<i>Business Administration</i>	20	5	6	3	26	8	5	
ALPHA EDUCATION AND TRAINING SHARE COMPANY Higher Institute of Distance Studies	3870	3079			3870	3079	433	88
<i>Accounting</i>	2108	1499			2108	1499	176	44
<i>Management</i>	1464	1291			1464	1291	230	44
<i>Auto-mechanics</i>	127	122			127	122	4	
<i>General Mechanics</i>	47	45			47	45	23	
<i>Law</i>	124	122			124	122		
MICROLINK INFORMATION TECHNOLOGY COLLEGE	1594	635	766	215	2360	850	455	184
<i>Computer Science</i>	884	215	560	104	1444	319	217	46
<i>Accounting</i>	389	185	119	63	508	248	158	73
<i>Marketing Management</i>	133	85	56	18	189	103	26	16
<i>Secretarial Science</i>	122	121	31	30	153	151	41	41
<i>Banking and Finance</i>	46	28			46	28	13	8
<i>Post Graduate</i>	20	1			20	1		
SALAM NURSES COLLEGE	123	123			123	123	33	33
<i>Nursing</i>	123	123			123	123	33	33
ROYAL COLLEGE	637	386	1011	551	1648	937	200	136
<i>Accounting</i>	318	184	428	200	746	384	151	87
<i>Marketing Management</i>	123	61	123	48	246	109		
<i>Secretarial Science</i>	133	133	264	264	397	397	49	49
<i>Law</i>	47	4	83	18	130	22		
<i>Business Administration</i>	16	4	31	12	47	16		
<i>Human Resource</i>			82	9	82	9		
HiLCoE COMPUTER TECHNOLOGY	158	53	141	38	299	91	158	61
<i>HiLCoE</i>	158	53	141	38	299	91	158	61
TOP COLLEGE	77	35	84	36	161	71	61	19
<i>Accounting</i>	77	35	84	36	161	71	61	19
ADDIS COLLEGE	217	32	357	31	574	63	55	4
<i>Automotive</i>	53		50	2	103	2	21	
<i>Building</i>	55	4	128	4	183	8	15	
<i>Electronics</i>	49	2	106	2	155	4	8	
<i>Drafting</i>	11	3	16	4	27	7		
<i>Servaing</i>	12		16		28		7	1
<i>Accounting</i>	37	23	41	19	78	42	4	3
NEW MILLENNIUM COLLEGE	618	322	549	284	1167	606	569	293
<i>Accounting</i>	359	186	222	114	581	300	295	145
<i>Marketing Management</i>	61	35	37	17	98	52	35	19
<i>Purchasing Supplies Management</i>	92	38	113	30	205	68	112	47
<i>Personnel and Human Resource Management</i>	16	7	46	9	62	16	36	9
<i>Secretarial Science and Office Management</i>	32	32	98	98	130	130	62	62
<i>Computer Science</i>	58	24	33	16	91	40	29	11
Grand Total	12619	7202	6472	2944	19091	10146	4280	1887

**Students Enrolled in Regular Undergraduate Degree Programmes by Institution, Department, Year of Study and Sex
2001/02 (1994E.X.) Ακαδημικ Ψεαρ – Φιρστ Σεμεστερ**

University/Institute/College/Faculty Department	Year I		Year II		Year III		Year IV		Year V and above		Total	
	BS	F	BS	F	BS	F	BS	F	BS	F	BS	F
ADDIS ABABA UNIVERSITY	2411	542	556	101	351	55	585	111	439	61	4342	870
College of Social Science	1169	306	60	16	47	4	118	15			1394	341
<i>History</i>			10		14		43	2			67	2
<i>Political Science & Int. Relation</i>			8	2	8		40	7			56	9
<i>Freshman Programme</i>	1169	306									1169	306
<i>Geography</i>			21	2	17		23	1			61	3
<i>Sociology & Social Administration</i>			21	12	8	4	12	5			41	21
Faculty of Business & Economics			56	29	9	2	45	21			110	52
<i>Accounting</i>			16	6	4	1	20	9			40	16
<i>Economics</i>			14	10	1		9	4			24	14
<i>Management & Public Administration</i>			26	13	4	1	16	8			46	22
Faculty of Education	50	4	75	3	72	3	29	5			226	15
<i>Educational Administration</i>			51		56	1	16				123	1
<i>Educational Psychology</i>			5	1	6	1	7	3			18	5
<i>Physical Educ. & Sports</i>	50	4									50	4
<i>Business Education</i>			19	2	10	1	6	2			35	5
Faculty of Law			38	9	65	18	76	20	70	21	249	68
<i>Law</i>			38	9	65	18	76	20	70	21	249	68
Faculty of Medicine	29	15			65	20	74	21	267	36	435	92
<i>Medicine</i>					65	20	74	21	267	36	406	77
<i>Anaesthesia</i>	29	15									29	15
Faculty of Science	1113	207	101	15	9	1	72	4			1295	227
<i>Geology & Geophysics</i>			2				6				8	
<i>Statistics</i>			5	3			16				21	3
<i>Biology</i>			37	5	3		10	1			50	6
<i>Chemistry</i>			15	2	1		16	1			32	3
<i>Mathematics</i>			29	5	3	1	19	2			51	8
<i>Physics</i>			13		2		5				20	
<i>Freshman</i>	1113	207									1113	207
Faculty of Technology			31	3	10	2	5		28		74	5
<i>Chemical Engineering</i>									3		3	
<i>Civil Engineering</i>					3	2	1		4		8	2
<i>Electrical Engineering</i>					3		1		3		7	
<i>Mechanical Engineering</i>					3		3		15		21	
<i>Architecture & Urban Planning</i>					1				3		4	
<i>Pre-Engineering</i>			31	3							31	3
Faculty of Veterinary Medicine			54		47	1	43	1	68	2	212	4
<i>Veterinary Medicine</i>			54		47	1	43	1	68	2	212	4
Institute of Language Studies			46	12	24	1	100	16			170	29
<i>Ethiopian languages & Literature</i>			20	5	4	1	40	8			64	14
<i>Linguistics</i>							4				4	
<i>Theatre Arts</i>			1		9		4	1			14	1
<i>Foreign languages & Literature</i>			25	7	11		52	7			88	14
Information Sciences (SISA)			34	10			20	8			54	18
<i>Library Science</i>			34	10			20	8			54	18
School of Pharmacy			11	4	3	3	3		6	2	23	9
<i>Pharmacy</i>			11	4	3	3	3		6	2	23	9
Yared Music School	25	8	25								50	8
<i>Music</i>	25	8	25								50	8
Fine Arts and Design	25	2	25								50	2
<i>Art</i>	25	2	25								50	2
DEBUB UNIVERSITY	1463	296	551	102	419	54	545	48	32	1	3010	501
Dilla College of Teacher Education and Health Sc.	468	78	350	52	232	22	319	34			1369	186
Freshman	468	78									468	78
<i>Social Science</i>	260	52									260	52
<i>Natural Science</i>	208	26									208	26
Faculty of Health Science			38	7	42	5	46	3			126	15
<i>Health Officer</i>			38	7	42	5	46	3			126	15

Faculty of Teacher Education			312	45	190	17	273	31			775	93
-------------------------------------	--	--	------------	-----------	------------	-----------	------------	-----------	--	--	------------	-----------

University/Institute/College/Faculty	Year I		Year II		Year III		Year IV		Year V and above		Total	
	BS	F	BS	F	BS	F	BS	F	BS	F	BS	F
<i>Chemistry</i>			40		19		39				98	
<i>Mathematics</i>			44	2	26		31				101	2
<i>Physics</i>			40	2	20		18				78	2
<i>Biology</i>			41	6	28	4	31	5			100	15
<i>English</i>			38	14	28	3	38	11			104	28
<i>Amharic</i>			32	8	18		28	3			78	11
<i>History</i>			37	1	25	2	40	4			102	7
<i>Geography</i>			40	12	26	8	48	8			114	28
Awassa College of Agriculture	896	206	151	41	141	27	158	13	32	1	1378	288
<i>Agricultural Engineering & Mechanizat8</i>			43	8	36	6	43	1	32	1	154	16
<i>Animal Production & Range Land Mgt.</i>			51	24	49	9	63	2			163	35
<i>Natural Science</i>	650	141									650	141
<i>Social Science</i>	246	65									246	65
<i>Plant Production & Dry Land Farming</i>			57	9	56	12	52	10			165	31
Wondo Genet College of Forestry	99	12	50	9	46	5	68	1			263	27
<i>Forestry</i>	99	12	50	9	46	5	68	1			263	27
ALEMAYA UNIVERSITY	995	208	515	96	400	46	525	55			2435	405
Faculty of Agriculture	34	7	202	41	142	19	188	9			566	76
<i>Agricultural Extension</i>			52	10	31		54	4			137	14
<i>Animal Science</i>			35	1	21	3	46	3			102	7
<i>Plant Science</i>			83	15	57	8	88	2			228	25
<i>MCFL Agri.Extension</i>	34	7	32	15	33	8					99	30
Faculty of Education			264	43	220	13	290	27			774	83
<i>Biology</i>			28	1	28	1	48	5			104	7
<i>Chemistry</i>			24	1	21		32	2			77	3
<i>Mathematics</i>			43	3	33	1	41				117	4
<i>Physics</i>			27		17		23				67	
<i>English</i>			52	17	43	2	40	6			135	25
<i>History</i>			31	4	31	1	45	3			107	8
<i>Geography</i>			59	17	47	8	61	11			167	36
Freshman	892	176									892	176
<i>Natural Science</i>	294	43									294	43
<i>Social Science</i>	598	133									598	133
Faculty of Health	69	25	49	12	38	14	47	19			203	70
<i>Public Health Officer</i>	69	25	49	12	38	14	47	19			203	70
ARBA MINCH WATER TECH. INSTITUTE	341	10	330	6	283	4	241	9	180	3	1375	32
<i>Hydraulics Engineering</i>			88	3	64	2	66	1	67		285	6
<i>Irrigation Engineering</i>			86		61	1	59		29	1	235	2
<i>Pre-Engineering</i>	341	10									341	10
<i>Electrical Engineering</i>			43	2	44	1	27	1	19	1	133	5
<i>Civil Engineerinmg</i>			86	1	79		60	6	42	1	267	8
<i>Mechanical Engineering</i>			27		35		29	1	23		114	1
BAHIR DAR UNIVERSITY	846	132	632	71	577	58	537	48	172	3	2764	312
Bahir Dar Polytechnic Institute	390	45	244	35	231	22	199	16	172	3	1236	121
<i>Freshman Programme</i>	390	45									390	45
<i>Pre . Engineering</i>			244	35							244	35
<i>Civil Engineering</i>					39	5	42	8	35	1	116	14
<i>Chemical Engineering</i>					34	3	26	3	25		85	6
<i>Electrical Engineering</i>					37	6	31	3	34	2	102	11
<i>Mechanical Engineering</i>					45	3	37		32		114	3
<i>Industrial Engineering</i>					40	5	32	2	25		97	7
<i>Textile Engineering</i>					36		31		21		88	
Bahirdar Teachers College	456	87	388	36	346	36	338	32			1528	191
<i>Faculty of Education</i>	456	87	388	36	346	36	338	32			1528	191
<i>Social Science</i>	227	43									227	43
<i>Natural Science</i>	229	44									229	44
<i>Amharic</i>			26	4	28	5	32	2			86	11
<i>Biology</i>			54	5	46	1	33	3			133	9
<i>Chemistry</i>			58	2	39	3	40	2			137	7
<i>English</i>			33	5	34	7	41	14			108	26
<i>Geography</i>			46	8	34	9	44	3			124	20
<i>History</i>			40	8	24	2	39	3			103	13
<i>Mathematics</i>			58	4	60	2	38				156	6
<i>Physics</i>			38		52	2	48	1			138	3
<i>Pd. Sc. Amharic</i>			1				2	1			3	1
<i>Pd. Sc. English</i>			9		5		3				17	
<i>Pd.Sc. Geography</i>			15		10	2	12	1			37	3
<i>Pd. Sc. Maths</i>			10		14	3	6	2			30	5
ETHIOPIAN CIVIL SERVICE COLLEGE	433	34	404	24	345	26					1182	84

University/Institute/College/Faculty	Year I		Year II		Year III		Year IV		Year V and above		Total	
	BS	F	BS	F	BS	F	BS	F	BS	F	BS	F
Department												
Faculty of Business and Economics	275	29	220	15	188	18					683	62
<i>Economics</i>	68	3	66	3	44	6					178	12
<i>Accounting</i>	134	24	112	12	95	11					341	47
<i>Development Administration</i>	73	2	42		49	1					164	3
Faculty of Law	116	4	119	5	109	5					344	14
<i>Law</i>	116	4	119	5	109	5					344	14
Faculty of Technology	42	1	65	4	48	3					155	8
<i>Urban Planning</i>	42	1	65	4	48	3					155	8
GONDER COLLEGE OF MEDICAL SCIENCE	54	9	111	25	51	6	79	11	112	11	407	62
<i>Medicine</i>			57	17	51	6	79	11	112	11	299	45
<i>Health Officer</i>	54	9	54	8							108	17
JIMMA UNIVERSITY	1160	233	571	87	520	73	425	42	211	20	2887	455
Jimma Institute of Health Science	1160	233	518	73	470	61	425	42	211	20	2784	429
Faculty of Business and Economics			143	32	131	26	163	24			437	82
<i>Accounting</i>			73	21	74	15	103	17			250	53
<i>Management</i>			70	11	57	11	60	7			187	29
Freshman	1015	214									1015	214
<i>Natural Science</i>	856	170									856	170
<i>Social Science</i>	159	44									159	44
Faculty of Technology			161	11	133	8	141	3	93	4	528	26
<i>Pre -engineering</i>			161	11							161	11
<i>Civil Engineering</i>					55	4	54	2	34	4	143	10
<i>Mechanical Engineering</i>					25		37		26		88	
<i>Electrical Engineering</i>					53	4	50	1	33		136	5
Faculty of Health Sciences	145	19	214	30	206	27	121	15	118	16	804	107
<i>Medicine</i>			68	9	75	10	121	15	118	16	382	50
<i>Health Officer</i>	56	6	55	8	53	4					164	18
<i>Post Basic Laboratory</i>	27	1	29	1	23	3					79	5
<i>Post Basic Nursing</i>	34	11	34	12	29	9					97	32
<i>Post Basic Env.Health</i>	28	1	28		26	1					82	2
Jimma College of Agriculture			53	14	50	12					103	26
<i>Horticulture</i>			53	14	50	12					103	26
KOTEBE COLLEGE OF TEACHER EDUCATION	75	11	40	6	32	1	17				164	18
<i>Health and Physical Education</i>	75	11	40	6	32	1	17				164	18
MEKELE UNIVERSITY	1195	234	483	73	289	30	402	45	74	3	2443	385
Mekele University College	1013	195	344	41	193	20	207	13	74	3	1831	272
Faculty of Agriculture			136	14	85	6	102	3			323	23
<i>Land Resource Management & Environmental Protection</i>			60	10	35	3	40	3			135	16
<i>Dryland Crop Production</i>			41	3	28	1	35				104	4
<i>Animal Range Science</i>			35	1	22	2	27				84	3
Freshman	1013	195									1013	195
<i>Freshman</i>	1013	195									1013	195
Faculty of Science & Technology			208	27	108	14	105	10	74	3	495	54
<i>Civil Engineering</i>			47	11	43	10	42	7	29	2	161	30
<i>Ectrical Engineering</i>			45	10							45	10
<i>Mechanical Engineering</i>			43								43	
<i>Industrial Engineering</i>			42	5	35	3	29	1	23		129	9
<i>Applied Geology</i>			31	1	30	1	34	2	22	1	117	5
Mekele Business College	143	32	110	27	96	10	195	32			544	101
<i>Freshman Programme</i>	143	32									143	32
<i>Accounting</i>			31	11	27	6	78	17			136	34
<i>Management</i>			36	10	25	3	56	10			117	23
<i>Economics</i>			43	6	44	1	61	5			148	12
Faculty of Law	39	7	29	5							68	12
<i>Law</i>	39	7	29	5							68	12
NAZARETH TECHNICAL COLLEGE	347	144	85	44	104	9	131	2			667	199
<i>Automotive Technology</i>			23	16	25		23				71	16
<i>Construction Technology</i>			21	11	28	4	50	2			99	17
<i>Drafting & Surveying</i>												
<i>Manufacturing Technology</i>			11	4	23		17				51	4
<i>Freshman Programme</i>	347	144									347	144
<i>Electricity / Electrons</i>			30	13	28	5	41				99	18
DEFENCE ENGINEERING COLLEGE	103		84		113		109	3	71		480	3
Grand Total	9423	1853	4362	635	3484	362	3596	374	1291	102	22156	3326

**Students Enrolled in Postgraduate Degree Programmes by Institution, Department,
Year of Study and Sex**

2001/02 (1994 E.C.) Academic Year - First Semester

University/Institute/College/Faculty	Year I		Year II		Year III & Above		Total	
	BS	F	BS	F	BS	F	BS	F
ADDIS ABABA UNIVERSITY	490	45	449	31	227	18	1166	94
College of Social Science	32	2	34	1	22	2	88	5
<i>Geography</i>	9		11				20	
<i>History</i>	6		4		8		18	
<i>Social Anthropology</i>	11	2	8	1	14	2	33	5
<i>Political Science</i>	6		11				17	
Demographic Training & Research Centre	11	2	9				20	2
<i>Demography</i>	11	2	9				20	2
Faculty of Business and Economics	64	14	66	6			130	20
<i>Business Administration</i>	20	4	20	1			40	5
<i>Economics</i>	24	5	22	2			46	7
<i>Regional and Local Development St.</i>	20	5	24	3			44	8
Faculty of Education	68	3	73	3	1		142	6
<i>Special Education</i>	9	2	7	1			16	3
<i>Curriculum and Instruction</i>	9		10				19	
<i>Educational Psychology</i>	5	1	7				12	1
<i>Educational Administration</i>	11		10	1			21	1
<i>Curriculum and Instruction (Distance Education)</i>	10		15	1	1		26	1
<i>EdPM (Distance Education)</i>	24		24				48	
Faculty of Medicine	103	11	100	8	187	12	390	31
<i>Anaesthesiology</i>	1		1		2		4	
<i>Anatomy</i>	4						4	
<i>Internal Medicine</i>	12	1	14	1	20		46	2
<i>Microbiology and Parasitology</i>	4		4		1	1	9	1
<i>Obsterics & Gynaecology</i>	11	1	11		31	1	53	2
<i>Ophthalmology</i>	4	2	7	1	10	1	21	4
<i>Orthopaedics</i>	4		4		7		15	
<i>Paediatrics and Child Health</i>	13	4	13	1	20	2	46	7
<i>Pathology</i>	4		2		5		11	
<i>Radiology</i>	7	1	8	1	10	1	25	3
<i>Surgery</i>	10		13		42		65	
<i>Physiology</i>	2		2		1		5	
<i>Pharmacology</i>	4						4	
<i>Public Health</i>	23	2	21	4	38	6	82	12
Faculty of Science	103	5	74	6			177	11
<i>Biology</i>	38	3	35	5			73	8
<i>Biology (Ph.D)</i>	2						2	
<i>Chemistry (PHD)</i>	2						2	
<i>Chemistry</i>	15		9				24	
<i>Mathematics</i>	17		10				27	
<i>Physics</i>	12	1	9				21	1
<i>Geology & Geophysics</i>	13	1	8	1			21	2
<i>Statistics</i>	4		3				7	
Faculty of Technology	48		32				80	
<i>Civil Engineering</i>	27		13				40	
<i>Electrical Engineering</i>	6		10				16	
<i>Mechanical Engineering</i>	15		9				24	
Faculty of Veterinary Medicine			25	2			25	2
<i>Veterinary Medicine</i>			25	2			25	2
Institute of Language Studies	39	5	19	2	17	4	75	11
<i>Literature</i>	7	1	8	1	5		20	2
<i>Linguistics</i>	9	1	4		6	2	19	3
<i>TEAM</i>	6	1	3	1	2		11	2
<i>TEFL</i>	17	2	4		4	2	25	4
Information Science (SISA)	18	3	13	3			31	6
<i>Information Science (SISA)</i>	18	3	13	3			31	6
School of Pharmacy	4		4				8	
<i>Pharmaceutics</i>	4		4				8	

University/Institute/College/Faculty Department	Year I		Year II		Year III & Above		Total	
	BS	F	BS	F	BS	F	BS	F
ALEMAYA UNIVERSITY	79	1	55	2	19	1	153	4
College of Agriculture	79	1	55	2	19	1	153	4
<i>Agricultural Engineering</i>	8		4		4		16	
<i>Agro Economics</i>	13		21		8	1	42	1
<i>Animal Sciences</i>	10		6	1	1		17	1
<i>Plant Sciences</i>	48	1	24	1	6		78	2
DEBUB UNIVERSITY	16		12	1			28	1
Wondo Genet College of Forestry	16		12	1			28	1
<i>Forestry</i>	16		12	1			28	1
Total	585	46	516	34	246	19	1347	99

Students Readmitted in Regular Diploma Programmes
by Institution, Department, Year of Study and Sex
2001/02 (1994 E.C.) First Semester

University/Institute/College/Faculty and Department	Year I		Year II		Year III		TOTAL	
	BS	F	BS	F	BS	F	BS	F
ADDIS ABABA UNIVERSITY	30	27					30	27
Faculty of Technology	2						2	
Building Technology	2						2	
Faculty of Medicine	27	26					27	26
Nursing	27	26					27	26
SISA	1	1					1	1
Library Science	1	1					1	1
ADDIS ABABA COLLEGE OF COMMERCE	26	12	8	4			34	16
Accounting	4		3				7	
Banking and Finance	8	4					8	4
Marketing Management	1	1	1				2	1
Purchasing and Supply Mgt.	7	1	2	2			9	3
Secretarial Science & Office Mgt (Bi-Lingual)	6	6	2	2			8	8
DEBUB UNIVERSITY	24	17	7	4			31	21
Dilla College of Teacher Education and Health Science	17	14	3	2			20	16
Faculty of Health	17	14	3	2			20	16
Public Health Nursing	7	7					7	7
Laboratory Technology	4	3					4	3
Environmental Health	6	4	3	2			9	6
Awassa College of Agriculture	5	3	4	2			9	5
Basic Science	5	3					5	3
General Agriculture			1				1	
Agricultural Engineering & Mechanization			1				1	
RDFS			2	2			2	2
Wondo Genet College of Forestry	2						2	
Forestry	2						2	
AMBO COLLEGE OF AGRICULTURE	4	3	6	2			10	5
General Agriculture	4	3	6	2			10	5
BAHIRDAR UNIVERSITY	5	2	6	1			11	3
Bahir Dar Teachers College	5	2	6	1			11	3
SSOM	2	1	2	1			4	2
Accounting	3	1	4				7	1
JIMMA COLLEGE OF TEACHER EDUCATION	3	2	10	1			13	3
A/Oromo			1	1			1	1
English			4				4	
History	1	1	2				3	1
Biology	1	1					1	1
Mathematics	1		3				4	
JIMMA UNIVERSITY	26	6	3	1			29	7
Jimma Institute of Health Science	26	6	3	1			29	7
Clinical Nursing	3	1					3	1
Pharmacy	7	3	3	1			10	4
Environmental Health	7	1					7	1
Public Health Nursing	5						5	
Medical Laboratory Technology	4	1					4	1
ADDIS ABABA COLLEGE OF COMMERCE	26	12	8	4			34	16
Accounting	4		3				7	
Banking & Finance	8	4					8	4
Marketing Management	1	1	1				2	1
Secretarial Science & Office Mgt (Bi-Lingual)	6	6	2	2			8	8
Purchasing & Supply Management	7	1	2	2			9	3
AMBO COLLEGE OF AGRICULTURE	4	3	6	2			10	5
General Agriculture	4	3	6	2			10	5
ALEMAYA UNIVERSITY	1	1	8	8			9	9
Faculty of Health	1	1	8	8			9	9
Environmental health			4	4			4	4
Medical Laboratory Technology			4	4			4	4
Public Health Nurse	1	1					1	1
ARBA MINCH WATER TECHNOLOGY INSTITUTE	2						2	
Pre-Engineering	2						2	
MEKALLE UNIVERSITY	4	1	3	2			7	3
Mekele Business College	4	1	3	2			7	3
Freshman	3	1					3	1
Management			1	1			1	1
Accounting			1	1			1	1
Banking and Finance			1				1	
Secretarial Sc. & Office Mag.	1						1	

University/Institute/College/Faculty and Department	Year I		Year II		Year III		TOTAL	
	BS	F	BS	F	BS	F	BS	F
GONDAR COLLEGE OF TEACHER EDUCATION	24	13	18	12			42	25
Amharic	3	2					3	2
English	5	5	6	4			11	9
Mathematics	5	2	2	1			7	3
Biology	6	2	2				8	2
Chemistry	2	2	2	1			4	3
Physics	1		5	5			6	5
Geography	2		1	1			3	1
ABIY ADDI COLLEGE OF TEACHER EDUCATION			1				1	
History			1				1	
AWASSA COLLEGE OF TEACHER EDUCATION	14	7	28	11			42	18
English	3	2	2	1			5	3
Amharic	5	4	11	10			16	14
Mathematics			5				5	
Physics			2				2	
Geography			1				1	
Biology	3	1	4				7	1
Chemistry			3				3	
Physical Education	3						3	
ETHIOPIAN CIVIL SERVICE COLLEGE	7	2	15	2			22	4
Faculty of Law	3		12	1			15	1
Low	3		12	1			15	1
Faculty of Business & Eco.	4	2	2				6	2
Accounting	4	2	2				6	2
Faculty of Technology			1	1			1	1
Urban Engineering			1	1			1	1
ETHIOPIAN MASS MEDIA TRAINING INSTITUTE	1	1	2				3	1
Print Media	1	1	2				3	1
MACHEW TECHNICAL COLLEGE	5	3	4				9	3
Freshman Program	5	3					5	3
Automotive Technology			1				1	
Electrical Technology			1				1	
Manufacturing Technology			2				2	
KOTEBE COLLEGE OF TEACHER EDUCATION	22	10	41	14			63	24
English			9	1			9	1
Ethiopian languages and Literature	3	2	6	6			9	8
Geography	1		6				7	
History	7	4	4				11	4
Health and Physical Education	4	1	6	1			10	2
Mathematics	4	3	2	1			6	4
Chemistry	1		4	4			5	4
Biology	2		1				3	
Physics			3	1			3	1
GONDER COLLEGE OF MEDICAL SCIENCE	28	17	8	5			36	22
Public Health Nuring	2	2					2	2
Clinical Nursing	8	8	5	4			13	12
Midwifery	2	2					2	2
Sanitary Science	8	4	3	1			11	5
Pharmacy	8	1					8	1

**Students Readmitted in Regular Undergraduate Degree Programmes
by Institution, Department, Year of Study and Sex**

2001/02 (1994 E.C.) Academic Year - First Semester

University/Institute/College/Faculty Department	Year I		Year II		Year III		Year IV		Year V		Total	
	BS	F	BS	F	BS	F	BS	F	BS	F	BS	F
ADDIS ABABA UNIVERSITY	240	77									240	77
College of Social Science	72	20									72	20
<i>Freshman</i>	63	19									63	19
<i>History</i>	4										4	
<i>Political Science & Int. Relation</i>	3	1									3	1
<i>Sociology & Social Administration</i>	2										2	
Faculty of Business & Economics	8	3									8	3
<i>Accounting</i>	2	1									2	1
<i>Economics</i>	1										1	
<i>Management & Public Administration</i>	5	2									5	2
Faculty of Education	13	6									13	6
<i>Business Education</i>	2										2	
<i>Educational Administration</i>	4	1									4	1
<i>Educational Psychology</i>	7	5									7	5
Faculty of Medicine	3	1									3	1
<i>Medicine</i>	3	1									3	1
Faculty of Science	95	40									95	40
<i>Freshman</i>	63	36									63	36
<i>Statistics</i>	3	2									3	2
<i>Biology</i>	11	2									11	2
<i>Chemistry</i>	4										4	
<i>Mathematics</i>	11										11	
<i>Physics</i>	1										1	
<i>Geology & Geophysics</i>	2										2	
Faculty of Technology	18	3									18	3
<i>Civil Engineering</i>	3	1									3	1
<i>Electrical Engineering</i>	5										5	
<i>Mechanical Engineering</i>	5										5	
<i>Architecture & Urban Planning</i>	1										1	
<i>Pre-Engineering</i>	4	2									4	2
Faculty of Veterinary Medicine	5										5	
<i>Veterinary Medicine</i>	5										5	
Institute of Language Studies	17	1									17	1
<i>Ethiopian languages & Literature</i>	11	1									11	1
<i>Foreign languages & Literature</i>	5										5	
<i>Theatre Arts</i>	1										1	
Law	1	1									1	1
Information Sciences (SISA)	2										2	
<i>Library Science</i>	2										2	
School of Pharmacy	5	2									5	2
<i>Pharmacy</i>	5	2									5	2
Yared Music	1										1	
DEBUB UNIVERSITY	32	14	27	1	11	2	2		1		73	17
Dilla College of Teacher Education and Health Sc.	24	8	15		6	2	1				46	10
Freshman	24	8									24	8
<i>Social Science</i>	14	5									14	5
<i>Natural Science</i>	10	3									10	3
Faculty of Health Science					1						1	
<i>Health Officer</i>					1						1	
Faculty of Teacher Education			15		5	2	1				21	2
<i>Mathematics</i>			1		1						2	
<i>Physics</i>			3		1						4	
<i>Biology</i>			4								4	
<i>History</i>					2	2					2	2
<i>Chemistry</i>			2		1		1				4	
<i>English</i>			1								1	
<i>Amharic</i>			4								4	

University/Institute/College/Faculty Department	Year I		Year II		Year III		Year IV		Year V		Total	
	BS	F	BS	F	BS	F	BS	F	BS	F	BS	F
Awassa College of Agriculture	5	4	5	1	4		1		1		16	5
<i>Agricultural Engineering & Mechanization</i>			1		2				1		4	
<i>Animal Production & Range Land Mgt.</i>			3	1	1		1				5	1
<i>Natural Science</i>	5	4									5	4
<i>Plant Production & Dry Land Farming</i>			1		1						2	
Wondo Genet College of Forestry	3	2	7		1						11	2
<i>Forestry</i>	3	2	7		1						11	2
ALEMAYA UNIVERSITY	20	7	10	2	3		1				34	9
Faculty of Agriculture			1		1		1				3	
<i>Agricultural Extension</i>							1				1	
<i>Animal Science</i>					1						1	
<i>Plant Science</i>			1								1	
Faculty of Education			9	2	2						11	2
<i>Biology</i>			2		1						3	
<i>Chemistry</i>			2		1						3	
<i>Mathematics</i>			2	1							2	1
<i>Physics</i>			1								1	
<i>English</i>			1								1	
<i>History</i>			1	1							1	1
Freshman	16	5									16	5
<i>Natural Science</i>	10	2									10	2
<i>Social Science</i>	6	3									6	3
Faculty of Health	4	2									4	2
<i>Public Health Officer</i>	4	2									4	2
ARBA MINCH WATER TECH. INSTITUTE	22	5	15		12	1					49	6
<i>Hydraulics Engineering</i>			6		3	1					9	1
<i>Irrigation Engineering</i>			3		3						6	
<i>Pre-Engineering</i>	22	5									22	5
<i>Electrical Engineering</i>			2		2						4	
<i>Civil Engineerinmg</i>			3		2						5	
<i>Mechanical Engineering</i>			1		2						3	
BAHIR DAR UNIVERSITY	24		34	9	15		5	1	1		79	10
Bahir Dar Polytechnic Institute	24		26	9	8		4	1	1		63	10
<i>Freshman Programme</i>	24										24	
<i>Civil Engineering</i>							1	1			1	1
<i>Mechanical Engineering</i>					1		1				2	
<i>Pre-Engineering</i>			26	9							26	9
<i>Textile Engineering</i>					2						2	
<i>Chemical Engineering</i>					4						4	
<i>Electrical Engineering</i>					1		2		1		4	
Bahirdar Teachers College			8		7		1				16	
<i>Biology</i>			2		1						3	
<i>Chemistry</i>			2								2	
<i>English</i>					1						1	
<i>History</i>					2						2	
<i>Geography</i>							1				1	
<i>Physics</i>			4		3						7	
ETHIOPIAN CIVIL SERVICE COLLEGE	7		8	2	19	3					34	5
Faculty of Business and Economics			2		7	1					9	1
<i>Economics</i>			1		4						5	
<i>Accounting</i>			1		3	1					4	1
Faculty of Law	7		6	2	12	2					25	4
<i>Law</i>	7		6	2	12	2					25	4

University/Institute/College/Faculty Department	Year I		Year II		Year III		Year IV		Year V		Total	
	BS	F	BS	F	BS	F	BS	F	BS	F	BS	F
JIMMA UNIVERSITY	25	10	28	5	22	4	5				80	19
Faculty of Business and Economics			7	2	6	1	1				14	3
<i>Management</i>			5		4	1	1				10	1
<i>Accounting</i>			2	2	2						4	2
Freshman	25	10									25	10
<i>Natural Science</i>	18	5									18	5
<i>Social Science</i>	7	5									7	5
Faculty of Technology			14	2	1		2				17	2
<i>Pre -engineering</i>			13	2							13	2
<i>Mechanical Engineering</i>			1		1		2				4	
Faculty of Health Sciences			7	1	15	3	2				24	4
<i>Post Basic Lab.</i>			2	1							2	1
<i>Medicine</i>			5		15	3	2				22	3
KOTEBE COLLEGE OF TEACHER EDUCATION	5	3	8				1				14	3
<i>Health and Physical Education</i>	5	3	8				1				14	3
MEKELE UNIVERSITY	19	9	25	2	1						71	13
Mekele University	19	9	25	2	1						71	13
<i>Freshman Programme</i>	19	9									19	9
Faculty of Dryland Agriculture			13	2	1						14	2
<i>Land Resource Management & Environmental Protection</i>			7	2							7	2
<i>Animal Range Science</i>			6		1						7	
Faculty of Science & Technology			12								12	
<i>Civil Engineering</i>			2								2	
<i>Mechanical Engineering</i>			2								2	
<i>Industrial Engineering</i>			3								3	
<i>Applied Geology</i>			5								5	
DEFENCE ENGINEERING COLLEGE											3	
GONDER COLLEGE OF MEDICAL SCIENCE	1	1	5		1		2		4		13	1
<i>Medicine</i>			2		1		2		4		9	
<i>Health Officer</i>	1	1	3								4	1

GRADUATER

Definition of Concepts

Graduated Students

These are students whose graduation has been approved by a University Senate or an equivalent organ of a given institution (e.g. Academic Commission) during the period starting from the beginning of the first semester of a specified academic year to the first day of the first semester of the next academic year.

Graduates from Regular Diploma, Undergraduate Degree and Postgraduate Degree
by Institution. Department and Sex
2001/02 (1994 E.C.) Academic Year

University/Institute/College/Faculty Department	Diploma		Undergraduate Degree		Postgraduate Degree		Total	
	BS	F	BS	F	BS	F	BS	F
ADDIS ABABA UNIVERSITY	269	64	548	100	397	30	1214	194
College of Social Science			94	12	33	2	127	14
<i>Geography</i>			23	1	9		32	1
<i>History</i>			30	2	6		36	2
<i>Poli. Scie. & Intrna.Relations</i>			32	7	5		37	7
<i>Sociology & Social Admin.</i>			9	2			9	2
<i>Social Antropology</i>					13	2	13	2
Faculty of Business & Economics			41	19	37	6	78	25
<i>Accounting</i>			18	8			18	8
<i>Economics</i>			7	3			7	3
<i>Management</i>			9	5			9	5
<i>Public Administration</i>			7	3			7	3
<i>Economic Policy Analysis</i>					18	3	18	3
<i>Regional and Local Development Studies</i>					19	3	19	3
Faculty of Education	49		26	6	87	3	162	9
<i>Business Education</i>	2		3	1	20		25	1
<i>Curriculum & Instruction</i>					11		11	
<i>Educational Administration</i>	47		16		10		73	
<i>Educational Psychology</i>			7	5	5		12	5
<i>Special Education</i>					6	1	6	1
<i>Curriculum & Instruction (Distance Education)</i>					12	1	12	1
<i>Education Management and Planning (Distance Education)</i>					23	1	23	1
Faculty of Law			62	19			62	19
Faculty of Medicine	146	59	54	4	87	8	287	71
<i>Medicine</i>			50	4			50	4
<i>Anaesthesiology</i>			4		1		5	
<i>Internal Medicine</i>					10		10	
<i>Gynaecology and Obstetrics</i>					8		8	
<i>Paediatrics and Child Health</i>					10	2	10	2
<i>Pathology</i>					4		4	
<i>Midwifery</i>	16	4					16	4
<i>Clinical Nurse</i>	86	49					86	49
<i>Laboratory Technology</i>	44	6					44	6
<i>Ophthalmology</i>					4		4	
<i>Orthopaedic Surgery</i>					2		2	
<i>Surgery</i>					13		13	
<i>Radiology</i>					5	1	5	1
<i>Public Health</i>					30	5	30	5
Faculty of Science			97	8	69	4	166	12
<i>Biology (2 Ph.D.)</i>			17	2	29	2	46	4
<i>Dryland Biodiversity</i>					5	1	5	1
<i>Chemistry (1 Ph.D.)</i>			17	1	9		26	1
<i>Computer Science</i>			8	3			8	3
<i>Geology and Geophysics</i>			6		7	1	13	1
<i>Mathematics</i>			16	1	9		25	1
<i>Physics</i>			15		8		23	
<i>Statistics</i>			18	1	2		20	1
Faculty of Technology	12	2	26		27		65	2
<i>Architecture & Urban Planning</i>			2				2	
<i>Building Technology</i>	12	2					12	2
<i>Chemical Engineering</i>			3				3	
<i>Civil Engineering</i>			5		12		17	
<i>Electrical Engineering</i>			3		3		6	
<i>Mechanical Engineering</i>			13		12		25	

University/Institute/College/Faculty Department	Diploma		Undergraduate Degree		Postgraduate Degree		Total	
	BS	F	BS	F	BS	F	BS	F
Faculty of Veterinary Medicine	54	3	22	1	11	1	87	5
<i>Veterinary Medicine</i>			22	1	11	1	33	2
<i>Animal Health</i>	54	3					54	3
Institute of Language Studies			98	18	20	3	118	21
<i>Ethiopian Language and Literature</i>			35	9			35	9
<i>Foreign Language and Literature</i>			56	7			56	7
<i>Linguistics</i>			3		4		7	
<i>Literature</i>			4	2	4	2	8	4
<i>TEFL</i>					8		8	
<i>TEAM</i>					4	1	4	1
<i>Theatre Arts</i>								
Information Studies	8		15	6	13	3	36	9
<i>Information Studies</i>					13	3	13	3
<i>Library Science</i>	8		15	6			23	6
Demographic Training and Research Center					9		9	
<i>Demography</i>					9		9	
School of Pharmacy			13	7	4		17	7
<i>Pharmacy</i>			13	7	4		17	7
DEBUB UNIVERSITY	286	53	463	43			749	96
Dilla College of Teacher Education and Health Science	123	34	276	29			399	63
Faculty of Health Science	123	34	43	3			166	37
<i>Enviromental Health</i>	37	11					37	11
<i>Laboratory Technician</i>	43	3					43	3
<i>Health Officer</i>			43	3			43	3
<i>Nurse</i>	43	20					43	20
Faculty of Education			233	26			233	26
<i>Chemistry</i>			34				34	
<i>Biology</i>			27	5			27	5
<i>Mathematics</i>			25				25	
<i>Physics</i>			15				15	
<i>History</i>			37	3			37	3
<i>Geography</i>			46	8			46	8
<i>English</i>			30	7			30	7
<i>Amharic</i>			19	3			19	3
Awassa College of Agriculture	96	16	130	13			226	29
<i>Agricultural Engineering and Mechnisation</i>	36	4	29	1			65	5
<i>Animal Production and Range Land Management</i>			51	2			51	2
<i>Plant Production and Dryland Farming</i>			50	10			50	10
<i>Home Science and Technology</i>	3	1					3	1
<i>General Agriculture</i>	34						34	
<i>RDFS</i>	23	11					23	11
Wondo Genet College of Forestry	67	3	57	1			124	4
<i>Forestry</i>	67	3	57	1			124	4
BAHIR DAR UNIVERSITY	88	17	438	29			526	46
Bahir Dar Polytechnic Institute			153	2			153	2
<i>Civil Engineering</i>			30	1			30	1
<i>Electrical Engineering</i>			29	1			29	1
<i>Chemical Engineering</i>			22				22	
<i>Industrial Engineering</i>			25				25	
<i>Mechanical Engineering</i>			28				28	
<i>Textile Engineering</i>			19				19	
Bahir Dar Teachers College	88	17	285	27			373	44
<i>Amaharic</i>			29	3			29	3
<i>Biology</i>			32	2			32	2
<i>Chemistry</i>			34	3			34	3
<i>English</i>			39	15			39	15
<i>Geography</i>			27				27	
<i>History</i>			35	2			35	2
<i>Mathematics</i>			27				27	
<i>Physics</i>			43				43	
<i>Pedagogical Science</i>			19	2			19	2
<i>Accounting</i>	48	4					48	4
<i>Secretarial Science and Office Management</i>	40	13					40	13

University/Institute/College/Faculty Department	Diploma		Undergraduate Degree		Postgraduate Degree		Total	
	BS	F	BS	F	BS	F	BS	F
GONDER COLLEGE OF MEDICAL SCIENCE	221	74	95	11			316	85
<i>Clinical Nurse</i>	68	38					68	38
<i>Public Nurse</i>	25	21					25	21
<i>Medicine</i>			49	4			49	4
<i>Health Officer</i>			46	7			46	7
<i>Laboratory Technology</i>	48	5					48	5
<i>Sanitary Science</i>	38	4					38	4
<i>Pharmacy</i>	42	6					42	6
ALEMAYA UNIVERSITY	107	31	530	52	47	3	684	86
Faculty of Agriculture			230	15	47	3	277	18
<i>Agricultural Economics</i>					16	1	16	1
<i>Agricultural Engineering</i>			1		6		7	
<i>Animal Sciences</i>			48	2	8	1	56	3
<i>Agricultural Extension</i>			55	4			55	4
<i>Agr.Ext.(Mid-Carrier)</i>			32	7			32	7
<i>Plant Science</i>			94	2	17	1	111	3
Faculty of Health	107	31	47	12			154	43
<i>Environmental Health</i>	25	6					25	6
<i>Medical Laboratory Technology</i>	42	3					42	3
<i>Public Health Nurse</i>	40	22					40	22
<i>Health Officer</i>			47	12			47	12
Faculty of Education			253	25			253	25
<i>Biology</i>			50	8			50	8
<i>Chemistry</i>			27	2			27	2
<i>Mathematics</i>			36				36	
<i>Physics</i>			18				18	
<i>Geography</i>			48	8			48	8
<i>History</i>			37	1			37	1
<i>English</i>			37	6			37	6
AMBO COLLEGE OF AGRICULTURE	320	22					320	22
<i>General Agriculture</i>	320	22					320	22
JIMMA UNIVERSITY	311	58	376	55			687	113
JIMMA INSTITUTE OF HEALTH SCIENCE	154	42	177	27			331	69
<i>Medicine</i>			53	10			53	10
<i>Post Basic Health Officer</i>			47	4			47	4
<i>Clinical Nurse</i>	20	9					20	9
<i>Public Nurse</i>	16	10	28	9			44	19
<i>Pharmacy</i>	37	9					37	9
<i>Laboratory Technology</i>	46	3	23	3			69	6
<i>Env't Health</i>	35	11	26	1			61	12
BUSINESS FACULTY			156	28			156	28
<i>Accounting</i>			101	19			101	19
<i>Mangement</i>			55	9			55	9
TECHNOLOGY FACULTY			43				43	
<i>Electrical Engineering</i>			28				28	
<i>Mechanical Engineering</i>			15				15	
<i>Civil Engineering</i>			32	4			32	4
JIMMA COLLEGE OF AGRICULTURE	157	16					157	16
<i>General Agriculture</i>	80	8					80	8
<i>Plant Science</i>	31	2					31	2
<i>Animal Science</i>	17	5					17	5
<i>Horticulture</i>	29	1					29	1
ADDIS ABABA COLLEGE OF COMMERCE	639	156					639	156
<i>Accounting</i>	262	21					262	21
<i>Banking & Finance</i>	91	7					91	7
<i>Marketing Management</i>	63	24					63	24
<i>Human Resource Management</i>	32	7					32	7
<i>Business Information System</i>	34	8					34	8
<i>Purchasing and Supply Management</i>	81	15					81	15
<i>Secretarial Sc. & Office Mgt. (Bi-lingual)</i>	68	67					68	67
<i>Secretarial Sc. & Office Mgt. (Tri-Lingual)</i>	8	7					8	7

University/Institute/College/Faculty Department	Diploma		Undergraduate Degree		Postgraduate Degree		Total	
	BS	F	BS	F	BS	F	BS	F
ARBA MINCH WATER TECH. INSTITUTE	32		133	5			165	5
<i>Civil Engineering</i>			39	3			39	3
<i>Electrical Engineering</i>			17	1			17	1
<i>Mechanical Engineering</i>			20				20	
<i>Irrigation Engineering</i>	14		26	1			40	1
<i>Hydraulics Engineering</i>	18		31				49	
MEKELE UNIVERSITY	113	39	351	37			464	76
Mekele University College			169	5			169	5
<i>Soil and Water Conservation</i>			41	2			41	2
<i>Dryland Crop production</i>			31				31	
<i>Animal and Range Science</i>			26				26	
<i>Applied Geology</i>			22	1			22	1
<i>Civil Engineering</i>			26	2			26	2
<i>Industrial Engineering</i>			23				23	
Mekele Business College	113	39	182	32			295	71
<i>Accounting</i>	42	16	73	17			115	33
<i>Management</i>	18	5	55	4			73	9
<i>Economics</i>			54	11			54	11
<i>Secretarial Science & Office Management</i>	21	12					21	12
<i>Banking & Finance</i>	32	6					32	6
NAZARETH TECHNICAL COLLEGE	131	2	114	1			245	3
<i>Automotive Technology</i>	24		23				47	
<i>Construction Technology</i>	26	1	39	1			65	2
<i>Drafting Technology</i>	22						22	
<i>Electricity/Electronics Technology</i>	19	1	38				57	1
<i>Manufacturing Technology</i>	24		14				38	
<i>Surveying Technology</i>	16						16	
ETHIOPIAN CIVIL SERVICE COLLEGE	161	13	216	17			377	30
<i>Accounting</i>	47	5	96	11			143	16
<i>Economics</i>			42	5			42	5
<i>Law</i>	61	3	13				74	3
<i>Dev't Administration</i>			48	1			48	1
<i>Urban Engineering</i>	53	5					53	5
<i>Urban planning</i>			17				17	
ABBIYI ADDI COLLEGE OF TEACHER EDUCATION	483	53					483	53
<i>Tigrigna</i>	46	12					46	12
<i>Amharic</i>	45	13					45	13
<i>English</i>	59	3					59	3
<i>Mathematics</i>	57	6					57	6
<i>Biology</i>	54	9					54	9
<i>Chemistry</i>	58	4					58	4
<i>Physics</i>	33	1					33	1
<i>History</i>	39	2					39	2
<i>Geography</i>	47	2					47	2
<i>Health and Physical Education</i>	45	1					45	1
AWASSA COLLEGE OF TEACHER EDUCATION	355	46					355	46
<i>English</i>	51	8					51	8
<i>Amharic</i>	40	33					40	33
<i>Mathematics</i>	39	1					39	1
<i>Physics</i>	38						38	
<i>Biology</i>	34	1					34	1
<i>Geography</i>	36						36	
<i>History</i>	47						47	
<i>Chemistry</i>	53	2					53	2
<i>Health and Physical Education</i>	17	1					17	1

University/Institute/College/Faculty Department	Diploma		Undergraduate Degree		Postgraduate Degree		Total	
	BS	F	BS	F	BS	F	BS	F
GONDAR COLLEGE OF TEACHER EDUCATION	292	55					292	55
<i>Amharic</i>	12	8					12	8
<i>English</i>	55	21					55	21
<i>Mathematics</i>	52	3					52	3
<i>Biology</i>	30	9					30	9
<i>Chemistry</i>	37	6					37	6
<i>Physics</i>	46	1					46	1
<i>Geography</i>	26	4					26	4
<i>History</i>	34	3					34	3
JIMMA COLLEGE OF TEACHER EDUCATION	329	115					329	115
<i>Oromigna</i>	46	34					46	34
<i>English</i>	49	14					49	14
<i>Amharic</i>	34	30					34	30
<i>Biology</i>	28	8					28	8
<i>Geography</i>	23	5					23	5
<i>History</i>	34	4					34	4
<i>Chemistry</i>	39	8					39	8
<i>Physics</i>	21						21	
<i>Mathematics</i>	30	2					30	2
<i>Adult Education</i>	25	10					25	10
KOTEBE COLLEGE OF TEACHER EDUCATION	399	132	17				416	132
<i>English</i>	62	23					62	23
<i>Ethiopian languages and Literature</i>	31	19					31	19
<i>Geography</i>	58	16					58	16
<i>History</i>	52	9					52	9
<i>Health and Physical Education</i>	39	8	17				56	8
<i>Mathematics</i>	41	12					41	12
<i>Chemistry</i>	41	17					41	17
<i>Biology</i>	48	21					48	21
<i>Physics</i>	27	7					27	7
DEFENCE ENGINEERING COLLEGE	92	3	68				160	3
<i>Communication</i>	8		6				14	
<i>Instrumentation</i>	7		10				17	
<i>Electrical Power</i>	12		4				16	
<i>Mechanical Power</i>	17		24				41	
<i>Manufacturing</i>	8		9				17	
<i>Design Technology</i>	5		9				14	
<i>Metallurgical Technology</i>	6		6				12	
<i>Computer Hardware Technology</i>	20	3					20	3
<i>Armament Technology</i>	9						9	
ETHIOPIAN MASS MEDIA TRAINING INSTITUTE	96	20					96	20
<i>Print Media</i>	45	7					45	7
<i>Radio Section</i>	24	9					24	9
<i>Television Section</i>	27	4					27	4
MAICHEW TECHNICAL COLLEGE	69	9					69	9
<i>Automotive Technology</i>	17						17	
<i>Construction Technology</i>	18	5					18	5
<i>Electrical Technology</i>	19	4					19	4
<i>Manufacturing Technology</i>	15						15	
Grand Total	4793	962	3349	350	444	33	8586	1345

FULL-TIME ACADEMIC TEACHING STAFF

Definition of Concepts

Academic Teaching Staff

Employees of institutions of higher education engaged in lecturing at third-level institutions. Graduate assistants are also regarded as academic teaching staff.

Full-time Academic Teaching Staff

These include regular employees of institutions of higher education engaged full-time in teaching, including Deans, Directors, Assistant Deans, Department Heads and Graduate Assistants who have an academic unit and therefore, have some academic rank as home-base. In addition, lectures following graduate programmes are included as full-time teaching staff under the academic institution they served on part-time basis.

Level of Education

This indicates either the highest grade completed or the highest certificate or diploma held by an employee.

Academic Rank

A distinct academic position bestowed on lecturers in institution of higher education based on their years of service and achievements while in service, and level of education.

Expatriate Teaching Staff

These are lecturers who are foreign nationals.

Full time Ethiopian Teaching Staff by Institution
Department, Academic Level and Sex
2001/02 (1994 E.C.) Academic Year First Semester

University/Institute/College/Faculty Department	Diploma		Bachelor Degree		Masters Degree		M.D/D.V Degree		Doctorate Degree		Others		Total	
	BS	F	BS	F	BS	F	BS	F	BS	F	BS	F	BS	F
ADDIS ABABA UNIVERSITY	103	20	125	16	260	20	95	5	205	3	49	18	837	82
College of Social Science	2		9	1	12				20				43	1
<i>Geography</i>	2		2		1				4				9	
<i>History</i>			3		2				7				12	
<i>Philosophy</i>			1		2				2				5	
<i>Poli. Scie. & Intrna.Relations</i>			2		6				4				12	
<i>Sociology & Social Adm.</i>			1	1	1				3				5	1
Faculty of Business & Economics			16	3	21	1			11		1		49	4
<i>Accounting</i>			8	1	6								14	1
<i>Economics</i>			5	1	6	1			8		1		20	2
<i>Management & Public Adm.</i>			3	1	9				3				15	1
Faculty of Education	1		5		21	1			14				41	1
<i>Business Administration</i>					5								5	
<i>Curriculum & Instruction</i>	1		4		5				3				13	
<i>Educational Administration</i>			1		5				3				9	
<i>Educational Psychology</i>					6	1			8				14	1
Faculty of Law			7	1	6				1				14	1
Faculty of Medicine	40	13	19	4	6	1	83	4	14	1	16	4	178	27
<i>Anatomy</i>			1				1		4	1	1		7	1
<i>Anaesthesiology</i>							2						2	
<i>Biochemistry</i>	3	1							1		1		5	1
<i>Community Health</i>					1		9		1				11	
<i>Internal Medicine</i>	3		1		1		17	1					22	1
<i>Microbiology and Parasitology</i>	3	2	3	1					2		1		9	3
<i>Obsterics & Gynaecology</i>							9	1			1		10	1
<i>Ophthalmology</i>							6						6	
<i>Orthopaedics</i>							3						3	
<i>Paediatrics</i>							10						10	
<i>Pathology</i>							4	1			1		5	1
<i>Pharmacology</i>			1						1		2	1	4	1
<i>Physiology</i>	2						1		5				8	
<i>Psychiatry</i>							3						3	
<i>Radiology</i>							3						3	
<i>Surgery</i>							13						13	
<i>School of Medical Laboratory Technology</i>	29	10	13	3	4	1	2	1			9	3	57	18
Faculty of Science	3		17		37	2			69	1	20	10	146	13
<i>Biology</i>			1		4	1			24		7	3	36	4
<i>Chemistry</i>			3		5				11		8	6	27	6
<i>Geology & Geophysics</i>			2		3				15		1		21	
<i>Mathematics</i>	1		7		10				8	1			26	1
<i>Physics</i>	2		3		7				6				18	
<i>Statistics</i>			1		7	1			2				10	1
<i>Geophysical Observatory</i>					1				3		4	1	8	1
Faculty of Technology	18		15	1	32	1			34		5		104	2
<i>Architecture and Urban Planning</i>			2		10	1			1				13	1
<i>Building Technology</i>	3				6								9	
<i>Chemical Engineering</i>			1		4				2		1		8	
<i>Civil Engineering</i>	6		3	1	3				12				24	1
<i>Electrical Engineering</i>	4				7				10		1		22	
<i>Material Research & Testing Department</i>	2		2		1				1				6	
<i>Mechanical Engineering</i>	3		7		1				8		3		22	
Faculty of Veterinary Medicine	18	2	1		12	1	11	1	6				48	4
<i>Anatomy & Embryology</i>	2	1					3	1					5	2
<i>Basic Science</i>	1				4								5	
<i>Clinical Studies</i>	5				3	1	2		1				11	1
<i>Microbiology, Infection desessie & Vet.pub. Health</i>	3				1		1		2				7	
<i>Pathology & Parasitology</i>	4	1			2		1		2				9	1
<i>Physiology</i>	1				1		2		1				5	
<i>Zootechnology</i>	2		1		1		2						6	

University/Institute/College/Faculty Department	Diploma		Bachlor Degree		Masters Degree		M.D/D.V Degree		Doctorate Degree		Others		Total	
	BS	F	BS	F	BS	F	BS	F	BS	F	BS	F	BS	F
Institute of Language Studies					31	5			20		2	1	53	6
<i>Ethiopian Language and Literature</i>					9	1			3				12	1
<i>Foreign Language and Literature</i>					15	4			15		2	1	32	5
<i>Linguistics</i>					2				2				4	
<i>Theatre Arts</i>					5								5	
School of Information Science for Africa	1		4	2	8	2							13	4
School of Graduate Studies									1				1	
School of Pharmacy	3		6		4				3				16	
Physical Education & Sports	1		9		3								13	
Institute of Development Research					4				3				7	
Demographic Training and Research Center					2								2	
Centre for Res. Tr. and Infor. for Women Dev. (CERTWID)					3	3			1	1			4	4
Institute of Educational Research					6				3				9	
Institute of Ethiopian Studies			4		5				3				12	
Institute of Patobiology (IPB)	6	3			9		1		1		4	2	21	5
University Library	1		6	2	12	1			1		1	1	21	4
School of Arts and Design	1		4		11	1							16	1
Yared Music School	8	2	3	2	15	1							26	5
DEBUB UNIVERSITY	44	5	55	5	93	6	18		18		3	2	231	18
Awassa College of Agriculture	18	1	11	1	26	3	2		9		2	2	68	7
<i>Agricultural Eng. and Mechan.</i>	5		6		7				1				19	
<i>Animal Production and Range Land Management</i>	6		2		8	1	2		5				23	1
<i>Home Science and Technology</i>			1	1	4	2					2	2	7	5
<i>Plant Production and Dry Land Farming</i>	7	1	2		7				3				19	1
Wondo Genet College of Forestry*	7	1	8	1	16	1			5		1		37	3
<i>Basic Science</i>	2	1	2		5						1		10	1
<i>Silviculture and Extension</i>	2		3	1	6	1			1				12	2
<i>Forestry Management and Utilization</i>	3		3		5				4				15	
Dilla Teacher Education and Health Sciences College	19	3	36	3	51	2	16		4				126	8
Faculty of Education	8	2	19	2	47	2			4				78	6
<i>Amharic</i>			1		5	1							6	1
<i>Biology</i>	3	1	4	1	8	1			1				16	3
<i>Chemistry</i>	2		3		7				2				14	
<i>English</i>			4		1								5	
<i>Geography</i>	1	1	2		6								9	1
<i>History</i>			3	1	3								6	1
<i>Mathematics</i>			1		5								6	
<i>Pedagogy</i>					6				1				7	
<i>Physics</i>	2		1		6								9	
Faculty of Health Sciences	11	1	17	1	4		16						48	2
<i>Health Officer</i>					1		11						12	
<i>Environmental Health</i>	3		5										8	
<i>Laboratory Technology</i>	5		3										8	
<i>Public Health Nursing</i>	3	1	7	1	1								11	2
<i>Biomedical & Behavioural Science</i>			2		2		5						9	
BAHIR DAR UNIVERSITY	16		54	2	80	1			12		2		164	3
Bahir Dar Teachers College	6		23	2	52	1			7		2		90	3
<i>Business</i>			10	1					1				11	1
<i>Amaharic</i>			1	1	5								6	1
<i>Biology</i>	3		4		4				1				12	
<i>Chemistry</i>	1		3		4				1				9	
<i>English</i>					4								4	
<i>Geography</i>					4				3				7	
<i>History</i>			3		2				1				6	
<i>Mathematics</i>					12								12	
<i>Pedagogy</i>			1		10	1							11	1
<i>Physics</i>	1				6								7	
<i>Law</i>			1								2		3	
<i>Physical Edu.</i>	1				1								2	
Bahir Dar Polytechnic Institute	10		31		28				5				74	
<i>Textile Engineering</i>					4				1				5	
<i>Civil Engineering</i>	5		11		4								20	
<i>Electrical Engineering</i>			8		6								14	
<i>Chemical Engineering</i>			6		7				1				14	
<i>Mechanical Engineering</i>	5		4		5				3				17	
<i>Industrial</i>			2		2								4	

University/Institute/College/Faculty Department	Diploma		Bachlor Degree		Masters Degree		M.D/D.V Degree		Doctorate Degree		Others		Total	
	BS	F	BS	F	BS	F	BS	F	BS	F	BS	F	BS	F
GONDER COLLEGE OF MEDICAL SCIENCE*	16	3	24	1	9	1			29	2	21		99	7
<i>Gondar Medical Science</i>	16	3	24	1	9	1			29	2	21		99	7
ALEMAYA UNIVERSITY	20	1	41	7	51	2	2		17		9		140	10
Faculty of Agriculture	9		8	1	9		2		12				40	1
<i>Agricultural Engineering</i>			2		2				3				7	
<i>Animal Science</i>			2		5		2						9	
<i>Plant Science</i>	9		4	1	2				9				24	1
Faculty of Education	5		10		41	2			4				60	2
<i>Biology</i>	2		1		7	2			1				11	2
<i>Chemistry</i>	3		1		6				1				11	
<i>English</i>			1		7				1				9	
<i>Mathematics</i>			1		7								8	
<i>Physics</i>			1		5				1				7	
<i>Pedagogy</i>					3								3	
<i>Geography</i>			1		4								5	
<i>History</i>			3										3	
<i>Physical Education</i>			1		2								3	
Faculty of Health	6	1	23	6	1				1		9		40	7
<i>Environmental Health</i>	1		5		1								7	
<i>Medical Laboratory</i>	2		6	1									8	1
<i>Public Health</i>			6	2					1		9		16	2
<i>Nursing</i>	3	1	6	3									9	4
AMBO COLLEGE OF AGRICULTURE	18	4	7		16				3		1		45	4
<i>Basic Science</i>	3		1		5								9	
<i>Plant Science</i>	7	3	3		3								13	3
<i>Animal Science</i>	3		1		3						1		8	
<i>Agricultural Engineering</i>	4	1	1		3				1				9	1
<i>Agricultural Economics & Extension</i>	1		1		2				2				6	
ADDIS ABABA COLLEGE OF COMMERCE	6	2	25	4	43	5			1				75	11
<i>Accounting</i>			4	2	8								12	2
<i>Banking&Finance</i>			3		6	1							9	1
<i>Secretarial Sc. & Office Mgt.</i>	3	2	10	2	1								14	4
<i>Purchasing & Supply Management</i>			5		4								9	
<i>Department of BIS</i>	2		2		1								5	
<i>Common Course</i>	1		1		23	4			1				26	4
KOTEBE COLLEGE OF TEACHER EDUCATION	9	2	12		63	2			5				89	4
<i>Biology</i>	3	2	2		7								12	2
<i>Chemistry</i>	2		3		4								9	
<i>Ethiopian Language</i>			1		5	1							6	1
<i>Geography</i>			1		7								8	
<i>Health and Physical Education</i>			2		4				2				8	
<i>History</i>					4				1				5	
<i>Mathematics</i>			1		7								8	
<i>Physics</i>	2		2		5								9	
<i>Phyloseohy, Economie & Civics</i>					4	1							4	1
<i>English</i>					8				1				9	
<i>Education</i>					8				1				9	
<i>Art and Music</i>	2												2	
AWASSA COLLEGE OF TEACHER EDUCATION	7	1	14	1	34				2				57	2
<i>Education</i>			1		7								8	
<i>Amharic</i>			1		4								5	
<i>English</i>			3	1	3								6	1
<i>Mathematics</i>			2		4								6	
<i>Biology</i>	2	1			4				1				7	1
<i>Physics</i>	2		3		2								7	
<i>Chemistry</i>	2				5								7	
<i>Geography</i>			1		2								3	
<i>History</i>			1		2				1				4	
<i>Health and Physical Education</i>	1		2		1								4	
ABBIYI ADDI COLLEGE OF TEACHER EDUCATION	4		30	2	8						2		44	2
<i>Ethiopian Languages and Literature</i>	3		4	1									7	1
<i>Health and Physical Education</i>			2										2	
<i>English</i>			4										4	
<i>Natural Science</i>	1		5		6						1		13	
<i>Social Science</i>			7	1									7	1
<i>Education</i>			4		1						1		6	
<i>Mathematics</i>			4		1								5	

University/Institute/College/Faculty Department	Diploma		Bachlor Degree		Masters Degree		M.D/D.V Degree		Doctorate Degree		Others		Total	
	BS	F	BS	F	BS	F	BS	F	BS	F	BS	F	BS	F
GONDAR COLLEGE OF TEACHER EDUCATION	2		9		30								41	
<i>Amharic</i>					4								4	
<i>English</i>			2		2								4	
<i>Mathematics</i>					6								6	
<i>Biology</i>					4								4	
<i>Chemistry</i>			1		3								4	
<i>Physics</i>					3								3	
<i>Geography</i>			1		2								3	
<i>History</i>			2		3								5	
<i>Education</i>			3		3								6	
<i>Health and Physical Education</i>	2												2	
<i>Pedagogy</i>														
ARBA MINCH WATER TECHNOLOGY INSTITUTE			26 1		32				1				59 1	
<i>Basic Science</i>			8 1		14								22 1	
<i>Civil Engineering</i>					3								10	
<i>Electrical Engineering</i>			5		2								7	
<i>Environmental Engineering</i>					3								3	
<i>Hydraulic Engineering</i>			3		2				1				6	
<i>Irrigation Engineering</i>			1		3								4	
<i>Mechanical Engineering</i>			2		5								7	
JIMMA COLLEGE OF TEACHER EDUCATION	6		14		29								49	
A/Oromo			3		1								4	
English			2		1								3	
Amaharic			1		2								3	
Education	2		1		7								10	
Geography			1		2								3	
History			3		1								4	
Civics			1										1	
Biology					3								3	
Chemistry	1				4								5	
Physical	1		1		2								4	
Mathematics					2								2	
Physical Edu.	2		1										3	
ANFE					4								4	
JIMMA UNIVERSITY	43 5		106 5		112 3		1		10				272 13	
Jimma Institute of Health Sciences	11 2		63 4		58 2				3				135 8	
Medical School	9 2		44 1		50 1				2				105 4	
<i>Cilnical Prog.</i>			12 1		23								35 1	
<i>Preclinical Health Prog.</i>	4 1		12 1		11				1				28 1	
<i>Community Health programme</i>			7		11 1				1				19 1	
<i>Pharmacy School</i>	2		8		2								12	
<i>Laboratory Technology School</i>	3 1		5		3								11 1	
Public Health	2		19 3		8 1				1				30 4	
<i>Public Health School</i>			1										1	
<i>Nursing School</i>			12 3		6 1								18 4	
<i>Environmental Health</i>	2		6		2				1				11	
Sciences & Liberal Art Faculty	10 2		12 1		28				1				51 3	
<i>Chemistry</i>	4 1		1		5				1				11 1	
<i>Biology</i>	2 1		2 1		4								8 2	
<i>Physics</i>	3				4								7	
<i>English</i>			4		4								8	
<i>Mathematics</i>			2		6								8	
<i>Social</i>			1		1								2	
<i>Phychology & Pedagogy</i>					3								3	
<i>Health & Physical Edu.</i>	1		2		1								4	
Technology Faculty	8		15										23	
<i>Civil Engineering</i>	3		6										9	
<i>Mechanical Engineering</i>	2		3										5	
<i>Electrical Engineering</i>	3		6										9	
Business Faculty			10		5				3				18	
<i>Management</i>			4		4				1				9	
<i>Accounting</i>			6										6	
<i>Economics</i>					1				2				3	
Jimma College of Agriculture	14 1		6		21 1		1		3				45 2	
<i>Animal Science</i>	4 1				6		1		1				12 1	
<i>Agricultural Engineering</i>	3		1		2								6	
<i>Agricultural Economics</i>	1		3		2 1								6 1	
<i>Plant Sciences</i>	6		2		11				2				21	

University/Institute/College/Faculty Department	Diploma		Bachlor Degree		Masters Degree		M.D/D.V Degree		Doctorate Degree		Others		Total	
	BS	F	BS	F	BS	F	BS	F	BS	F	BS	F	BS	F
MAKELE UNIVERSITY	20	3	76	5	43	2			7				146	10
MAKELE UNIVERSITY COLLEGE	17	1	51	3	31	1			6				105	5
<i>Civil Engineering</i>	3		7						1				11	
<i>Industrial Engineering</i>	2		4		3								9	
<i>Mechanical Engineering</i>			4										4	
<i>Electrical Engineering</i>	1		3	1	1								5	1
<i>Applied Geology</i>			4	1	2			1					7	1
<i>Animal & Range Science</i>	3		2	1	4			2					11	1
<i>Dry land crop Science</i>	3	1	1		4	1		1					9	2
<i>Land Resource Management & Env.</i>	3		1		3			1					8	
<i>English</i>			7		3								10	
<i>Mathematics</i>			5		4								9	
<i>Biology</i>			2		3								5	
<i>Chemistry</i>	1		2		1								4	
<i>Physics</i>	1		3		1								5	
<i>SPSU</i>			6		2								8	
MAKELE BUSINESS COLLEGE	3	2	25	2	12	1			1				41	5
<i>Accounting</i>			8	1									8	1
<i>Economics</i>			4		6	1		1					11	1
<i>Management</i>			4		6								10	
<i>Secretarial Science and Office Management</i>	3	2	2										5	2
<i>Law</i>			7	1									7	1
TIGRAY ARTS COLLEGE	11		4		2						1		18	
<i>Fine Arts Department</i>	3				2								5	
<i>Music Department</i>	7										1		8	
<i>Theatrical Arts</i>	1		2										3	
<i>Common course</i>			2										2	
NAZARETH TECHNICAL COLLEGE	27	2	50	3	32		1						110	5
<i>Automotive Technology</i>	4		5		2								11	
<i>Construction Technology</i>	3		7	1	3								13	1
<i>Drafting and Surveying Technology</i>	6	1	11		1								18	1
<i>Electricity/Electronics Technology</i>	5	1	5		7								17	1
<i>Manufacturing Technology</i>	4		3		5								12	
<i>Surveying Technology</i>	3		2		2								7	
<i>Applied and Natural Science</i>	2		12		4								18	
<i>Language and Social Science .</i>			5	2	3								8	2
<i>Vocational Dep't</i>					5		1						6	
ETHIOPIAN CIVIL SERVICE COLLEGE	10	5	52	5	93	4			2				157	14
<i>Business & Economics Faculty</i>			21	2	32	1			1				54	3
<i>Faculty of Law</i>			7	1	21	1							28	2
<i>Technology Faculty</i>	1		16	1	10	1			1				28	2
<i>English</i>					12	1							12	1
<i>Computer Science</i>			2	1	2								4	1
<i>Library</i>	9	5	2		1								12	5
<i>Continuing Education</i>					1								1	
<i>Curr. & Educ. Technology</i>					2								2	
<i>Entrance exam center</i>					2								2	
<i>Physical Education & Sports</i>			1										1	
<i>Distance Education</i>			3		5								8	
<i>IFRGS</i>					5								5	
DEFENCE ENGINEERING COLLEGE	32	3	13		12	1							57	4
<i>Metallurgy</i>	3				3								6	
<i>Mechanical Engineering</i>			1		1								2	
<i>Manufacturing</i>			5										5	
<i>Mechanical Power</i>	15		2		7								24	
<i>Design Technology Department</i>	14	3	5		1	1							20	4
ETHIOPIA MASS MEDIA TRAINING INSTITUTE	11	7	2	1	6				1		2	1	22	9
<i>Ethiopia Mass Media Training Institute</i>	11	7	2	1	6				1		2	1	22	9
MAICHEW TECHNICAL COLLEGE			29		1								30	
<i>Automotive Technology</i>			6										6	
<i>Construction Technology</i>			7		1								8	
<i>Electrical Technology</i>			6										6	
<i>Manufacturing Technology</i>			6										6	
<i>General Courses</i>			4										4	
Grand Total	405	63	768	58	1049	47	117	5	313	5	90	21	2742	199

* 1993 E.C. Data

Full time Expatriate Teaching Staff by Institution
Department, Academic Level and Sex
2001/02 (1994 E.C.) Academic Year First Semester

University/Institute/College/Faculty	Department	Diploma		Bachelor Degree		Masters Degree		M.D/D.V Degree		Doctorate Degree		Others		Total	
		BS	F	BS	F	BS	F	BS	F	BS	F	BS	F	BS	F
ADDIS ABABA UNIVERSITY						5		1		35	1		1	42	1
College of Social Science						1				5				6	
<i>Geography</i>										2				2	
<i>History</i>						1								1	
<i>Philosophy</i>										1				1	
<i>Sociology & Social Admin.</i>										2				2	
Faculty of Business & Economics										2			1	3	
<i>Accounting</i>													1	1	
<i>Management & Public Adm.</i>										2				2	
Faculty of Education										1				1	
<i>Curriculum & Instruction</i>										1				1	
Faculty of Medicine						3				6				9	
<i>Anatomy</i>										2				2	
<i>Biochemistry</i>										2				2	
<i>Community Health</i>						1								1	
<i>Pathology</i>										1				1	
<i>Pharmacology</i>										1				1	
<i>Physiology</i>						1								1	
<i>Surgery</i>						1								1	
Faculty of Science										8				8	
<i>Chemistry</i>										3				3	
<i>Mathematics</i>										2				2	
<i>Physics</i>										3				3	
Faculty of Technology										3				3	
<i>Civil Engineering</i>										1				1	
<i>Electrical Engineering</i>										2				2	
Institute of Language Studies										1				1	
<i>Foreign Language and Literature</i>										1				1	
School of Pharmacy						1		1		5	1			7	1
Demographic Training and Research Center										3				3	
Institute of Ethiopian Studies										1				1	
DEBUB UNIVERSITY				3	2	7	3			5	1			15	6
Awassa College of Agriculture				1	1	2	2							3	3
<i>Home Science and Technology</i>				1	1	2	2							3	3
Wondo Genet College of Forestry*				1	1	4	1			1	1			6	3
<i>Basic Science</i>				1	1	1	1							2	2
<i>Silviculture and Extension</i>						1				1	1			2	1
<i>Forestry Management and Utilization</i>						2								2	
Dilla Teacher Education and Health Sciences College				1		1				4				6	
Faculty of Education				1		1				4				6	
<i>Chemistry</i>										1				1	
<i>History</i>				1										1	
<i>Mathematics</i>						1								1	
<i>Physics</i>										3				3	
BAHIR DAR UNIVERSITY						4				2				6	
Bahir Dar Teachers College						3				2				5	
<i>Business</i>						3								3	
<i>Mathematics</i>										1				1	
<i>Physics</i>										1				1	
Bahir Dar Polytechnic Institute						1								1	
<i>Civil Engineering</i>						1								1	

University/Institute/College/Faculty Department	Diploma		Bachelor Degree		Masters Degree		M.D/D.V Degree		Doctorate Degree		Others		Total	
	BS	F	BS	F	BS	F	BS	F	BS	F	BS	F	BS	F
GONDER COLLEGE OF MEDICAL SCIENCE					1				4	3			5	3
<i>Gondar Medical Science</i>					1				4	3			5	3
ALEMAYA UNIVERSITY					2				20				22	
Faculty of Agriculture									18				18	
<i>Agricultural Engineering</i>									4				4	
<i>Animal Science</i>									5				5	
<i>Plant Science</i>									9				9	
Faculty of Education					2				2				4	
<i>Chemistry</i>					2								2	
<i>Physics</i>									2				2	
AWASSA COLLEGE OF TEACHER EDUCATION	1	1			1								2	1
<i>English</i>	1	1											1	1
<i>Physics</i>					1								1	
ABBIIYI ADDI COLLEGE OF TEACHER EDUCATION					1	1							1	1
<i>English</i>					1	1							1	1
GONDAR COLLEGE OF TEACHER EDUCATION			2	1									2	1
<i>English</i>			2	1									2	1
ARBA MINCH WATER TECHNOLOGY INSTITUTE					6				5				11	
<i>Civil Engineering</i>									1				1	
<i>Electrical Engineering</i>					2				1				3	
<i>Hydraulic Engineering</i>					1				2				3	
<i>Irrigation Engineering</i>									1				1	
<i>Mechanical Engineering</i>					3								3	
JIMMA UNIVERSITY					10	2			11				21	2
Jimma Institute of Health Sciences					1	1			5				6	1
Medical School									5				5	
<i>Preclinical Health Prog.</i>									5				5	
Public Health					1	1							1	1
<i>Nursing School</i>					1	1							1	1
Technology Faculty					7				5				12	
<i>Civil Engineering</i>					4				2				6	
<i>Mechanical Engineering</i>					1				2				3	
<i>Electrical Engineering</i>					2				1				3	
Business Faculty					2	1			1				3	1
<i>Management</i>					2	1							2	1
<i>Accounting</i>									1				1	
MAKELE UNIVERSITY			1		5				4				10	
MAKELE UNIVERSITY COLLEGE			1		5				4				10	
<i>Civil Engineering</i>					3								3	
<i>Industrial Engineering</i>					2				1				3	
<i>Mechanical Engineering</i>			1										1	
<i>Applied Geology</i>									3				3	
TIGRAY ARTS COLLEGE											1		1	
<i>Music Department</i>											1		1	
ETHIOPIAN CIVIL SERVICE COLLEGE					6	2			5	1			11	3
<i>Business & Economics Faculty</i>					4	2			4	1			8	3
<i>Faculty of Law</i>									1				1	
<i>Technology Faculty</i>					2								2	
MAICHEW TECHNIC COLLEGE			1										1	
<i>Manufacturing Technology</i>			1										1	
Grand Total	1	1	7	3	48	8	1		91	6	2		150	18

* 1993 E.C. Data

Full time Teaching Staff by Institution
Department, Academic Level and Sex
2001/02 (1994 E.C.) Academic Year First Semester

University/Institute/College/Faculty	Department	Diploma		Bachelor Degree		Masters Degree		M.D/D.V Degree		Doctorate Degree		Others		Total	
		BS	F	BS	F	BS	F	BS	F	BS	F	BS	F	BS	F
ADDIS ABABA UNIVERSITY		103	20	125	16	265	20	96	5	240	4	50	18	879	83
College of Social Science		2		9	1	13				25				49	1
<i>Geography</i>		2		2		1				6				11	
<i>History</i>				3		3				7				13	
<i>Philosophy</i>				1		2				3				6	
<i>Poli. Scie. & Intrna.Relations</i>				2		6				4				12	
<i>Sociology & Social Admin.</i>				1	1	1				5				7	1
Faculty of Business & Economics				16	3	21	1			13		2		52	4
<i>Accounting</i>				8	1	6						1		15	1
<i>Economics</i>				5	1	6	1			8		1		20	2
<i>Management & Public Adm.</i>				3	1	9				5				17	1
Faculty of Education		1		5		21	1			15				42	1
<i>Business Administration</i>						5								5	
<i>Curriculum & Instruction</i>		1		4		5				4				14	
<i>Educational Administration</i>				1		5				3				9	
<i>Educational Psychology</i>						6	1			8				14	1
Faculty of Law				7	1	6				1				14	1
Faculty of Medicine		40	13	19	4	9	1	83	4	20	1	16	4	187	27
<i>Anatomy</i>				1				1		6	1	1		9	1
<i>Anaesthesiology</i>								2						2	
<i>Biochemistry</i>		3	1							3		1		7	1
<i>Community Health</i>						2		9		1				12	
<i>Internal Medicine</i>		3		1		1		17	1					22	1
<i>Microbiology and Parasitology</i>		3	2	3	1					2		1		9	3
<i>Obsterics & Gynaecology</i>								9	1			1		10	1
<i>Ophthalmology</i>								6						6	
<i>Orthopaedics</i>								3						3	
<i>Paediatrics</i>								10						10	
<i>Pathology</i>								4	1	1		1		6	1
<i>Pharmacology</i>				1						2		2	1	5	1
<i>Physiology</i>		2				1		1		5				9	
<i>Psychiatry</i>								3						3	
<i>Radiology</i>								3						3	
<i>Surgery</i>						1		13						14	
<i>School of Medical Laboratory Technology</i>		29	10	13	3	4	1	2	1			9	3	57	18
Faculty of Science		3		17		37	2			77	1	20	10	154	13
<i>Biology</i>				1		4	1			24		7	3	36	4
<i>Chemistry</i>				3		5				14		8	6	30	6
<i>Geology & Geophysics</i>				2		3				15		1		21	
<i>Mathematics</i>		1		7		10				10	1			28	1
<i>Physics</i>		2		3		7				9				21	
<i>Statistics</i>				1		7	1			2				10	1
<i>Geop hysical Observatory</i>						1				3		4	1	8	1
Faculty of Technology		18		15	1	32	1			37		5		107	2
<i>Architecture and Urban Planning</i>				2		10	1			1				13	1
<i>Building Technology</i>		3				6								9	
<i>Chemical Engineering</i>				1		4				2		1		8	
<i>Civil Engineering</i>		6		3	1	3				13				25	1
<i>Electrical Engineering</i>		4				7				12		1		24	
<i>Material Research & Testing Department</i>		2		2		1				1				6	
<i>Mechanical Engineering</i>		3		7		1				8		3		22	
Faculty of Veterinary Medicine		18	2	1		12	1	11	1	6				48	4
<i>Anatomy & Embryology</i>		2	1					3	1					5	2
<i>Basic Science</i>		1				4								5	
<i>Clinical Studies</i>		5				3	1	2		1				11	1
<i>Microbiology,Infection desessie & Vet.pub. Health</i>		3				1		1		2				7	
<i>Pathology & Parasitology</i>		4	1			2		1		2				9	1
<i>Physiology</i>		1				1		2		1				5	
<i>Zootechnology</i>		2		1		1		2						6	
Institute of Language Studies						31	5			21		2	1	54	6
<i>Ethiopian Language and Literature</i>						9	1			3				12	1
<i>Foreign Language and Literature</i>						15	4			16		2	1	33	5
<i>Linguistics</i>						2				2				4	
<i>Theatre Arts</i>						5								5	

University/Institute/College/Faculty Department	Diploma		Bachelor Degree		Masters Degree		M.D/D.V Degree		Doctorate Degree		Others		Total	
	BS	F	BS	F	BS	F	BS	F	BS	F	BS	F	BS	F
School of Information Science for Africa	1		4	2	8	2							13	4
School of Graduate Studies									1				1	
School of Pharmacy	3		6		5		1		8	1			23	1
Physical Education & Sports	1		9		3								13	
Institute of Development Research					4				3				7	
Demographic Training and Research Center					2				3				5	
Centre for Res. Tr. and Infor. for Women Dev. (CERTW)					3	3			1	1			4	4
Institute of Educational Research					6				3				9	
Institute of Ethiopian Studies			4		5				4				13	
Institute of Patobiology (IPB)	6	3			9		1		1		4	2	21	5
University Library	1		6	2	12	1			1		1	1	21	4
School of Arts and Design	1		4		11	1							16	1
Yared Music School	8	2	3	2	15	1							26	5
DEBUB UNIVERSITY	44	5	58	7	100	9	18		23	1	3	2	246	24
Awassa College of Agriculture	18	1	12	2	28	5	2		9		2	2	71	10
<i>Agricultural Eng.and Mechan.</i>	5		6		7				1				19	
<i>Animal Production and Range Land Management</i>	6		2		8	1	2		5				23	1
<i>Basic Science</i>														
<i>General Agriculture</i>														
<i>Home Science and Technology</i>			2	2	6	4					2	2	10	8
<i>Plant Production and Dry Land Farming</i>	7	1	2		7				3				19	1
Wondo Genet College of Forestry*	7	1	9	2	20	2			6	1	1		43	6
<i>Basic Science</i>	2	1	3	1	6	1					1		12	3
<i>Silviculture and Extension</i>	2		3	1	7	1			2	1			14	3
<i>Forestry Management and Utilization</i>	3		3		7				4				17	
Dilla Teacher Education and Health Sciences College	19	3	37	3	52	2	16		8				132	8
Faculty of Education	8	2	20	2	48	2			8				84	6
<i>Amharic</i>			1		5	1							6	1
<i>Biology</i>	3	1	4	1	8	1			1				16	3
<i>Chemistry</i>	2		3		7				3				15	
<i>English</i>			4		1								5	
<i>Geography</i>	1	1	2		6								9	1
<i>History</i>			4	1	3								7	1
<i>Mathematics</i>			1		6								7	
<i>Pedagogy</i>					6				1				7	
<i>Physics</i>	2		1		6				3				12	
Faculty of Health Sciences	11	1	17	1	4		16						48	2
<i>Health Officer</i>					1		11						12	
<i>Environmental Health</i>	3		5										8	
<i>Laboratory Technology</i>	5		3										8	
<i>Public Health Nursing</i>	3	1	7	1	1								11	2
<i>Biomedical & Behavioural Science</i>			2		2		5						9	
BAHIR DAR UNIVERSITY	16		54	2	84	1			14		2		170	3
Bahir Dar Teachers College	6		23	2	55	1			9		2		95	3
<i>Business</i>			10	1	3				1				14	1
<i>Amaharic</i>			1	1	5								6	1
<i>Biology</i>	3		4		4				1				12	
<i>Chemistry</i>	1		3		4				1				9	
<i>English</i>					4								4	
<i>Geography</i>					4				3				7	
<i>History</i>			3		2				1				6	
<i>Mathematics</i>					12				1				13	
<i>Pedagogy</i>			1		10	1							11	1
<i>Physics</i>	1				6				1				8	
<i>Law</i>			1								2		3	
<i>Physical Edu.</i>	1				1								2	
Bahir Dar Polytechnic Institute	10		31		29				5				75	
<i>Textile Engineering</i>					4				1				5	
<i>Civil Engineering</i>	5		11		5								21	
<i>Electrical Engineering</i>			8		6								14	
<i>Chemical Engineering</i>			6		7				1				14	
<i>Mechanical Engineering</i>	5		4		5				3				17	
<i>Social, Applied and Natural Science</i>														
<i>Industrial</i>			2		2								4	
GONDER COLLEGE OF MEDICAL SCIENCE	16	3	24	1	10	1			33	5	21		104	10
<i>Gondar Medical Science</i>	16	3	24	1	10	1			33	5	21		104	10

University/Institute/College/Faculty Department	Diploma		Bachelor Degree		Masters Degree		M.D/D.V Degree		Doctorate Degree		Others		Total	
	BS	F	BS	F	BS	F	BS	F	BS	F	BS	F	BS	F
ALEMAYA UNIVERSITY	20	1	41	7	53	2	2		37		9		162	10
Faculty of Agriculture	9		8	1	9		2		30				58	1
<i>Agricultural Economics</i>									7				11	
<i>Agricultural Engineering</i>			2		2									
<i>Agricultural Extension</i>														
<i>Animal Science</i>			2		5		2		5				14	
<i>Plant Science</i>	9		4	1	2				18				33	1
Faculty of Education	5		10		43	2			6				64	2
<i>Biology</i>	2		1		7	2			1				11	2
<i>Chemistry</i>	3		1		8				1				13	
<i>English</i>			1		7				1				9	
<i>Mathematics</i>			1		7								8	
<i>Physics</i>			1		5				3				9	
<i>Pedagogy</i>					3								3	
<i>Geography</i>				1	4								5	
<i>History</i>			3										3	
<i>Physical Education</i>			1		2								3	
Faculty of Health	6	1	23	6	1				1		9		40	7
<i>Environmental Health</i>	1		5		1								7	
<i>Medical Laboratory</i>	2		6	1									8	1
<i>Public Health</i>			6	2					1		9		16	2
<i>Nursing</i>	3	1	6	3									9	4
AMBO COLLEGE OF AGRICULTURE	18	4	7		16				3		1		45	4
<i>Basic Science</i>	3		1		5								9	
<i>Plant Science</i>	7	3	3		3								13	3
<i>Animal Science</i>	3		1		3						1		8	
<i>Agricultural Engineering</i>	4	1	1		3				1				9	1
<i>Agricultural Economics & Extension</i>	1		1		2				2				6	
ADDIS ABABA COLLEGE OF COMMERCE	6	2	25	4	43	5			1				75	11
<i>Accounting</i>			4	2	8								12	2
<i>Banking&Finance</i>			3		6	1							9	1
<i>Secretarial Sc. & Office Mgt.</i>	3	2	10	2	1								14	4
<i>Purchasing & Supply Management</i>			5		4								9	
<i>Department of BIS</i>	2		2		1								5	
<i>Common Course</i>	1		1		23	4			1				26	4
KOTEBE COLLEGE OF TEACHER EDUCATION	9	2	12		63	2			5				89	4
<i>Biology</i>	3	2	2		7								12	2
<i>Chemistry</i>	2		3		4								9	
<i>Ethiopian Language</i>			1		5	1							6	1
<i>Geography</i>			1		7								8	
<i>Health and Physical Education</i>			2		4				2				8	
<i>History</i>					4				1				5	
<i>Home Economics</i>														
<i>Mathematics</i>			1		7								8	
<i>Physics</i>	2		2		5								9	
<i>Phyloseohy, Economie & Civics</i>					4	1							4	1
<i>English</i>					8				1				9	
<i>Education</i>					8				1				9	
<i>Art and Music</i>	2												2	
AWASSA COLLEGE OF TEACHER EDUCATION	8	2	14	1	35				2				59	3
<i>Education</i>			1		7								8	
<i>Amharic</i>			1		4								5	
<i>English</i>	1	1	3	1	3								7	2
<i>Mathematics</i>			2		4								6	
<i>Biology</i>	2	1			4				1				7	1
<i>Physics</i>	2		3		3								8	
<i>Chemistry</i>	2				5								7	
<i>Geography</i>			1		2								3	
<i>History</i>			1		2				1				4	
<i>Health and Physical Education</i>	1		2		1								4	
ABBIIYI ADDI COLLEGE OF TEACHER EDUCATION	4		30	2	9	1					2		45	3
<i>Ethiopian Languages and Literature</i>	3		4	1									7	1
<i>Health and Physical Education</i>			2										2	
<i>English</i>			4		1	1							5	1
<i>Natural Science</i>	1		5		6						1		13	
<i>Social Science</i>			7	1									7	1
<i>Education</i>			4		1						1		6	
<i>Mathematics</i>			4		1								5	

University/Institute/College/Faculty Department	Diploma		Bachelor Degree		Masters Degree		M.D/D.V Degree		Doctorate Degree		Others		Total	
	BS	F	BS	F	BS	F	BS	F	BS	F	BS	F	BS	F
GONDAR COLLEGE OF TEACHER EDUCATION	2		11 1		30								43 1	
<i>Amharic</i>					4								4	
<i>English</i>			4 1		2								6 1	
<i>Mathematics</i>					6								6	
<i>Biology</i>					4								4	
<i>Chemistry</i>			1		3								4	
<i>Physics</i>					3								3	
<i>Geography</i>			1		2								3	
<i>History</i>			2		3								5	
<i>Physiology</i>			3		3								6	
<i>Health and Physical Education</i>	2				3								2	
ARBA MINCH WATER TECHNOLOGY INSTITUTE			26 1		38				6				70 1	
<i>Basic Science</i>			8 1		14								22 1	
<i>Civil Engineering</i>			7		3				1				11	
<i>Electrical Engineering</i>			5		4				1				10	
<i>Environmental Engineering</i>					3								3	
<i>Hydraulic Engineering</i>			3		3				3				9	
<i>Irrigation Engineering</i>			1		3				1				5	
<i>Mechanical Engineering</i>			2		8								10	
JIMMA COLLEGE OF TEACHER EDUCATION	6		14		29								49	
A/Oromo			3		1								4	
English			2		1								3	
Amaharic			1		2								3	
Education	2		1		7								10	
Geography			1		2								3	
History			3		1								4	
Civics			1										1	
Biology					3								3	
Chemistry	1				4								5	
Physical	1		1		2								4	
Mathematics					2								2	
Physical Edu.	2		1										3	
ANFE					4								4	
JIMMA UNIVERSITY	43 5		106 5		122 5		1		21				293 15	
Jimma Institute of Health Sciences	11 2		63 4		59 3				8				141 9	
Medical School	9 2		44 1		50 1				7				110 4	
<i>Clinical Prog.</i>			12 1		23								35 1	
<i>Preclinical Health Prog.</i>	4 1		12		11				6				33 1	
<i>Community Health programme</i>			7		11 1				1				19 1	
<i>Pharmacy School</i>	2		8		2								12	
<i>Laboratory Technology School</i>	3 1		5		3								11 1	
Public Health	2		19 3		9 2				1				31 5	
<i>Public Health School</i>			1										1	
<i>Nursing School</i>			12 3		7 2								19 5	
<i>Environmental Health</i>	2		6		2				1				11	
Sciences & Liberal Art Faculty	10 2		12 1		28				1				51 3	
<i>Chemistry</i>	4 1		1		5				1				11 1	
<i>Biology</i>	2 1		2 1		4								8 2	
<i>Physics</i>	3				4								7	
<i>English</i>			4		4								8	
<i>Mathematics</i>			2		6								8	
<i>Social</i>			1		1								2	
<i>Psychology & Pedagogy</i>					3								3	
<i>Health & Physical Edu.</i>	1		2		1								4	
Technology Faculty	8		15		7				5				35	
<i>Civil Engineering</i>	3		6		4				2				15	
<i>Mechanical Engineering</i>	2		3		1				2				8	
<i>Electrical Engineering</i>	3		6		2				1				12	
Business Faculty			10		7 1				4				21 1	
<i>Management</i>			4		6 1				1				11 1	
<i>Accounting</i>			6						1				7	
<i>Economics</i>					1				2				3	
Jimma College of Agriculture	14 1		6		21 1		1		3				45 2	
<i>Animal Science</i>	4 1				6		1		1				12 1	
<i>Agricultural Engineering</i>	3		1		2								6	
<i>Agricultural Economics</i>	1		3		2 1								6 1	
<i>Plant Sciences</i>	6		2		11				2				21	

University/Institute/College/Faculty Department	Diploma		Bachelor Degree		Masters Degree		M.D/D.V Degree		Doctorate Degree		Others		Total	
	BS	F	BS	F	BS	F	BS	F	BS	F	BS	F	BS	F
MAKELE UNIVERSITY	20	3	77	5	48	2			11				156	10
MAKELE UNIVERSITY COLLEGE	17	1	52	3	36	1			10				115	5
<i>Civil Engineering</i>		3		7		3			1					14
<i>Industrial Engineering</i>		2		4		5			1					12
<i>Mechanical Engineering</i>				5										5
<i>Electrical Engineering</i>		1		3	1	1							5	1
<i>Applied Geology</i>				4	1	2			4				10	1
<i>Animal & Range Science</i>		3		2	1	4			2				11	1
<i>Dry land crop Science</i>		3	1	1		4	1		1				9	2
<i>Land Resource Management & Env.</i>		3		1		3			1				8	
<i>English</i>				7		3							10	
<i>Mathematics</i>				5		4							9	
<i>Biology</i>				2		3							5	
<i>Chemistry</i>		1		2		1							4	
<i>Physics</i>		1		3		1							5	
<i>SPSU</i>				6		2							8	
MAKELE BUSINESS COLLEGE	3	2	25	2	12	1			1				41	5
<i>Accounting</i>				8	1								8	1
<i>Economics</i>				4		6	1		1				11	1
<i>Management</i>				4		6							10	
<i>Secretarial Science and Office Management</i>		3	2	2									5	2
<i>Law</i>				7	1								7	1
TIGRAY ARTS COLLEGE	11		4		2						2		19	
<i>Fine Arts Department</i>		3				2							5	
<i>Music Department</i>		7									2		9	
<i>Theatrical Arts</i>		1		2									3	
<i>Common course</i>				2									2	
NAZARETH TECHNICAL COLLEGE	27	2	50	3	32		1						110	5
<i>Automotive Technology</i>		4		5		2							11	
<i>Construction Technology</i>		3		7	1	3							13	1
<i>Drafting and Surveying Technology</i>		6	1	11		1							18	1
<i>Electricity/Electronics Technology</i>		5	1	5		7							17	1
<i>Manufacturing Technology</i>		4		3		5							12	
<i>Surveying Technology</i>		3		2		2							7	
<i>Applied and Natural Science</i>		2		12		4							18	
<i>Language and Social Science .</i>				5	2	3							8	2
<i>Vocational Dep't</i>						5		1					6	
ETHIOPIAN CIVIL SERVICE COLLEGE	10	5	52	5	99	6			7	1			168	17
<i>Business & Economics Faculty</i>				21	2	36	3		5	1			62	6
<i>Faculty of Law</i>				7	1	21	1		1				29	2
<i>Technology Faculty</i>		1		16	1	12	1		1				30	2
<i>English</i>						12	1						12	1
<i>Computer Science</i>				2	1	2							4	1
<i>Library</i>		9	5	2		1							12	5
<i>Continuing Education</i>						1							1	
<i>Curr. & Educ. Technology</i>						2							2	
<i>Entrance exam center</i>						2							2	
<i>Physical Education & Sports</i>				1									1	
<i>Distance Education</i>				3		5							8	
<i>IFRGS</i>						5							5	
<i>Others</i>														
DEFENCE ENGINEERING COLLEGE	32	3	13		12	1							57	4
<i>Metallurgy</i>		3				3							6	
<i>Mechanical Engineering</i>				1		1							2	
<i>Manufacturing</i>				5									5	
<i>Mechanical Power</i>		15		2		7							24	
<i>Design Technology Department</i>		14	3	5		1	1						20	4
ETHIOPIA MASS MEDIA TRAINING INSTITUTE	11	7	2	1	6				1		2	1	22	9
<i>Ethiopia Mass Media Training Institute</i>		11	7	2	1	6			1		2	1	22	9
MAICHEW TECHNICAL COLLEGE			30		1								31	
<i>Automotive Technology</i>				6									6	
<i>Construction Technology</i>				7		1							8	
<i>Electrical Technology</i>				6									6	
<i>Manufacturing Technology</i>				7									7	
<i>General Courses</i>				4									4	
Grand Total	406	64	775	61	1097	55	118	5	404	11	92	21	2892	217

* 1993 E.C. Data

Full time Ethiopian Teaching Staff by Institution,
Department, Academic Rank and Sex
2001/02 (1994 E.C.) Academic Year First Semester

University/Institute/College/Faculty Department	Professor		Associate Professor		Assistant Professor		Lecturer		Assistant Lecturer		Graduate Assistant		Others		Total	
	BS	F	BS	F	BS	F	BS	F	BS	F	BS	F	BS	F	BS	F
ADDIS ABABA UNIVERSITY	19		120	1	198	8	190	17	70	7	16	4	224	45	837	82
College of Social Science	2		13		13		10		3	1			2		43	1
<i>Geography</i>			2		2		3						2		9	
<i>History</i>	1		4		3		2		2						12	
<i>Philosophy</i>			1		1		3								5	
<i>Poli. Scie. & Intrna.Relations</i>			6		5		1								12	
<i>Sociology & Social Adm.</i>	1				2		1		1	1					5	1
Faculty of Business & Economics	1		3		9		21	2	11		4	2			49	4
<i>Accounting</i>					1		7	1	6						14	1
<i>Economics</i>	1		2		6		6	1	3		2	1			20	2
<i>Management & Public Adm.</i>			1		2		8		2		2	1			15	1
Faculty of Education			13		7		15	1	4		1		1		41	1
<i>Business Administration</i>			1				4								5	
<i>Curriculum & Instruction</i>			2		3		3		3		1		1		13	
<i>Educational Administration</i>			3		2		3		1						9	
<i>Educational Psychology</i>			7		2		5	1							14	1
Faculty of Law	1		1		4		6		2	1					14	1
Faculty of Medicine	3		37	1	53	4	13	2	11	3	4		57	17	178	27
<i>Anatomy</i>			1		4	1					1		1		7	1
<i>Anaesthesiology</i>					2										2	
<i>Biochemistry</i>			1										4	1	5	1
<i>Community Health</i>	1		4		4		2								11	
<i>Internal Medicine</i>			8	1	9		2						3		22	1
<i>Microbiology and Parasitology</i>	1		1		2	1	1						4	2	9	3
<i>Obsterics & Gynaecology</i>			2		8	1									10	1
<i>Ophthalmology</i>			1		4		1								6	
<i>Orthopaedics</i>					2								1		3	
<i>Paediatrics</i>	1		6		3										10	
<i>Pathology</i>			2		2	1							1		5	1
<i>Pharmacology</i>			1							1			2	1	4	1
<i>Physiology</i>			3		2		1						2		8	
<i>Psychiatry</i>			1		2										3	
<i>Radiology</i>			1		2										3	
<i>Surgery</i>			5		7								1		13	
<i>School of Medical Laboratory Technology</i>							6	2	11	3	2		38	13	57	18
Faculty of Science	7		20		44	1	35	2	14		2		24	10	146	13
<i>Biology</i>	3		7		14		4	1	1				7	3	36	4
<i>Chemistry</i>	2		4		5		5		3				8	6	27	6
<i>Geology & Geophysics</i>	1		5		9		3		2				1		21	
<i>Mathematics</i>			3		6	1	9		6		1		1		26	1
<i>Physics</i>					6		7		2				3		18	
<i>Statistics</i>	1				2		6	1			1				10	1
<i>Geop hysical Observatory</i>			1		2		1						4	1	8	1
Faculty of Technology	2		14		21		30	1	10		4	1	23		104	2
<i>Architecture and Urban Planning</i>			1		1		9	1			2				13	1
<i>Building Technology</i>							5		1				3		9	
<i>Chemical Engineering</i>			1		2		3		1				1		8	
<i>Civil Engineering</i>			3		9		3		2		1	1	6		24	1
<i>Electrical Engineering</i>	2		3		6		6						5		22	
<i>Material Research & Testing Department</i>			1				2		1				2		6	
<i>Mechanical Engineering</i>			5		3		2		5		1		6		22	
Faculty of Veterinary Medicine			2		11	1	11		4	1			20	2	48	4
<i>Anatomy & Embryology</i>							1		2	1			2	1	5	2
<i>Basic Science</i>					1		2						2		5	
<i>Clinical Studies</i>					3	1	3						5		11	1
<i>Microbiology,Infection desessie & Vet.pub. Health</i>					3				1				3		7	
<i>Pathology & Parasitology</i>			2		2		1						4	1	9	1
<i>Physiology</i>					1		2		1				1		5	
<i>Zootechnology</i>					1		2						3		6	
Institute of Language Studies	1		6		21		23	5					2	1	53	6
<i>Ethiopian Language and Literature</i>			3		2		7	1							12	1
<i>Foreign Language and Literature</i>			2		16		12	4					2	1	32	5
<i>Linguistics</i>	1		1		2										4	
<i>Theatre Arts</i>					1		4								5	

University/Institute/College/Faculty Department	Professor		Associate Professor		Assistant Professor		Lecturer		Assistant Lecturer		Graduate Assistant		Others		Total	
	BS	F	BS	F	BS	F	BS	F	BS	F	BS	F	BS	F	BS	F
School of Information Science for Africa					2	1	6	1	3	1	1	1	1		13	4
School of Graduate Studies			1												1	
School of Pharmacy	1		2		1		3		6				3		16	
Physical Education & Sports													13		13	
Institute of Development Research			1		3		3								7	
Demographic Training and Research Center							2								2	
Centre for Res. Tr. and Infor. for Women Dev. (CERTWID)					1	1	3	3							4	4
Institute of Educational Research			2		3		4								9	
Institute of Ethiopian Studies	1		1		2		2		1				5		12	
Institute of Patobiology (IPB)			4		3		3		1				10	5	21	5
University Library													21	4	21	4
School of Arts and Design													16	1	16	1
Yared Music School													26	5	26	5
DEBUB UNIVERSITY			9		20		95	8	25	2	35	2	47	6	231	18
Awassa College of Agriculture			3		7		27	3	6	1	5		20	3	68	7
<i>Agricultural Eng. and Mechan.</i>					1		7		5		1		5		19	
<i>Animal Production and Range Land Management</i>			3		3		9	1			2		6		23	1
<i>Home Science and Technology</i>							4	2	1	1			2	2	7	5
<i>Plant Production and Dry Land Farming</i>					3		7				2		7	1	19	1
Wondo Genet College of Forestry*			6		1		16	3			7		7		37	3
<i>Basic Science</i>			1				4	1			2		3		10	1
<i>Silviculture and Extension</i>			1		1		7	2			2		1		12	2
<i>Forestry Management and Utilization</i>			4				5				3		3		15	
Dilla Teacher Education and Health Sciences College					12		52	2	19	1	23	2	20	3	126	8
Faculty of Education					5		46	2	3	1	15	1	9	2	78	6
<i>Amharic</i>							5	1			1				6	1
<i>Biology</i>					1		9	1	1	1	2		3	1	16	3
<i>Chemistry</i>					3		5				3		3		14	
<i>English</i>							1				4				5	
<i>Geography</i>							6		1		1		1	1	9	1
<i>History</i>							3		1		2	1			6	1
<i>Mathematics</i>							5				1				6	
<i>Pedagogy</i>					1		6								7	
<i>Physics</i>							6				1		2		9	
Faculty of Health Sciences					7		6		16		8	1	11	1	48	2
<i>Health Officer</i>					7		1		4						12	
<i>Environmental Health</i>									3		2		3		8	
<i>Laboratory Technoloy</i>									1		2		5		8	
<i>Public Health Nursing</i>							1		4		3	1	3	1	11	2
<i>Biomedical & Behavioural Science</i>							4		4		1				9	
BAHIR DAR UNIVERSITY					21		70	1	15		40	2	18		164	3
Bahir Dar Teachers College					17		41	1	3		21	2	8		90	3
<i>Business</i>					1						10	1			11	1
<i>Amaharic</i>					3		2				1	1			6	1
<i>Biology</i>					1		4		2		2		3		12	
<i>Chemistry</i>					1		4				2		2		9	
<i>English</i>							4								4	
<i>Geography</i>							3		4						7	
<i>History</i>					1		2				3				6	
<i>Mathematics</i>					1		11								12	
<i>Pedagogy</i>					3		7	1	1						11	1
<i>Physics</i>					3		3						1		7	
<i>Law</i>											3				3	
<i>Physical Edu.</i>													2		2	
Bahir Dar Polytechnic Institute					4		29		12		19		10		74	
<i>Textile Engineering</i>							5								5	
<i>Civil Engineering</i>							4		6		5		5		20	
<i>Electrical Engineering</i>							6		2		6				14	
<i>Chemical Engineering</i>					1		7		3		3				14	
<i>Mechanical Engineering</i>					3		5		1		3		5		17	
<i>Industrial</i>							2				2				4	
GONDER COLLEGE OF MEDICAL SCIENCE			9		23	2	16	1	23		12	1	16	3	99	7
<i>Gondar Medical Science</i>			9		23	2	16	1	23		12	1	16	3	99	7

University/Institute/College/Faculty Department	Professor		Associate Professor		Assistant Professor		Lecturer		Assistant Lecturer		Graduate Assistant		Others		Total	
	BS	F	BS	F	BS	F	BS	F	BS	F	BS	F	BS	F	BS	F
ALEMAYA UNIVERSITY			6		16		57	2	14	2	27	5	20	1	140	10
Faculty of Agriculture			5		11		7		1	1	7		9		40	1
<i>Agricultural Engineering</i>			1		3		1				2				7	
<i>Animal Science</i>			1		2		4				2				9	
<i>Plant Science</i>			3		6		2		1	1	3				24	1
Faculty of Education			1		4		40	2	3		7		5		60	2
<i>Biology</i>			1				7	2			1		2		11	2
<i>Chemistry</i>					2		5				1		3		11	
<i>English</i>					1		7		1						9	
<i>Mathematics</i>							7				1				8	
<i>Physics</i>					1		5				1				7	
<i>Pedagogy</i>							3								3	
<i>Geography</i>							4				1				5	
<i>History</i>										1	2				3	
<i>Physical Education</i>							2		1						3	
Faculty of Health					1		10		10	1	13	5	6	1	40	7
<i>Environmental Health</i>							1		2		3		1		7	
<i>Medical Laboratory</i>									5		1	1	2		8	1
<i>Public Health</i>					1		9		1		5	2			16	2
<i>Nursing</i>									2	1	4	2	3	1	9	4
AMBO COLLEGE OF AGRICULTURE	1				3		18		10	3	2		11	1	45	4
<i>Basic Science</i>					1		4		3				2		10	
<i>Plant Science</i>							4		7	3	2				13	3
<i>Animal Science</i>							4						3		7	
<i>Agricultural Engineering</i>	1				1		2						4	1	8	1
<i>Agricultural Economics & Extension</i>					1		4						2		7	
ADDIS ABABA COLLEGE OF COMMERCE					2		50	6	4	1	12	2	7	2	75	11
<i>Accounting</i>					1		6		3	1	2	1			12	2
<i>Banking&Finance</i>							6	1			3				9	1
<i>Secretarial Sc. & Office Mgt.</i>							8	1	1		2	1	3	2	14	4
<i>Purchasing & Supply Management</i>							4				5				9	
<i>Department of BIS</i>							2						3		5	
<i>Common Course</i>					1		24	4					1		26	4
KOTEBE COLLEGE OF TEACHER EDUCATION			1		23		47	2	1		8		9	2	89	4
<i>Biology</i>					5		2				2		3	2	12	2
<i>Chemistry</i>					1		3				3		2		9	
<i>Ethiopian Language</i>					1		5	1							6	1
<i>Geography</i>					2		6								8	
<i>Health and Physical Education</i>					4		2		1		1				8	
<i>History</i>					3		2								5	
<i>Mathematics</i>							8								8	
<i>Physics</i>							5				2		2		9	
<i>Phyloseohy, Economie & Civics</i>					1		3	1							4	1
<i>English</i>			1		3		5								9	
<i>Education</i>					3		6								9	
<i>Art and Music</i>													2		2	
AWASSA COLLEGE OF TEACHER EDUCATION					2		44		3	1	1		7	1	57	2
<i>Education</i>							8								8	
<i>Amharic</i>							5								5	
<i>English</i>							5		1	1					6	1
<i>Mathematics</i>							6								6	
<i>Biology</i>					1		4						2	1	7	1
<i>Physics</i>							3		2				2		7	
<i>Chemistry</i>							5						2		7	
<i>Geography</i>							3								3	
<i>History</i>					1		3								4	
<i>Health and Physical Education</i>							2				1		1		4	
ABBIIYI ADDI COLLEGE OF TEACHER EDUCATION							9		18		11	2	6		44	2
<i>Ethiopian Languages and Literature</i>									3		1	1	3		7	1
<i>Health and Physical Education</i>									2						2	
<i>English</i>									3		1				4	
<i>Natural Science</i>							6		1		4		2		13	
<i>Social Science</i>									5		2	1			7	1
<i>Education</i>							2		2		1		1		6	
<i>Mathematics</i>							1		2		2				5	

University/Institute/College/Faculty Department	Professor		Associate Professor		Assistant Professor		Lecturer		Assistant Lecturer		Graduate Assistant		Others		Total	
	BS	F	BS	F	BS	F	BS	F	BS	F	BS	F	BS	F	BS	F
GONDAR COLLEGE OF TEACHER EDUCATION							31		5		3		2		41	
<i>Amharic</i>							4								4	
<i>English</i>							2		1		1				4	
<i>Mathematics</i>							6								6	
<i>Biology</i>							4								4	
<i>Chemistry</i>							4								4	
<i>Physics</i>							3								3	
<i>Geography</i>							2		1						3	
<i>History</i>							3		2						5	
<i>Education</i>							3		1		2				6	
<i>Health and Physical Education</i>													2		2	
ARBA MINCH WATER TECHNOLOGY INSTITUTE					1		34		2		22	1			59	1
<i>Basic Science</i>							15				7	1			22	1
<i>Civil Engineering</i>							4				6				10	
<i>Electrical Engineering</i>							2		2		3				7	
<i>Environmental Engineering</i>							3								3	
<i>Hydraulic Engineering</i>					1		2				3				6	
<i>Irrigation Engineering</i>							3				1				4	
<i>Mechanical Engineering</i>							5				2				7	
JIMMA COLLEGE OF TEACHER EDUCATION							35		6		2		6		49	
A/Oromo							3		1						4	
English							1		2						3	
Amaharic							3								3	
Education							8						2		10	
Geography							3								3	
History							2		1		1				4	
Civics											1				1	
Biology							3								3	
Chemistry							4						1		5	
Physical							2		1				1		4	
Mathematics							2								2	
Physical Edu.									1				2		3	
ANFE							4								4	
JIMMA UNIVERSITY			2		55	1	80	3	44	1	48	3	43	5	272	13
Jimma Institute of Health Sciences			2		43	1	28	2	34	1	17	2	11	2	135	8
Medical School			2		39	1	23	1	20		12		9	2	105	4
<i>Clinical Prog.</i>					23		7	1	5						35	1
<i>Preclinical Health Prog.</i>					8		7		4		5		4	1	28	1
<i>Community Health programme</i>			2		8	1	3		5		1				19	1
<i>Pharmacy School</i>							2		4		4				12	
<i>Laboratory Technology School</i>							4		2		2		3	1	11	1
Public Health					4		5	1	14	1	5	2	2		30	4
<i>Public Health School</i>									1						1	
<i>Nursing School</i>					2		4	1	9	1	3	2			18	4
<i>Environmental Health</i>					2		1		4		2		2		11	
Sciences & Liberal Art Faculty					2		27		3		9	1	10	2	51	3
<i>Chemistry</i>					1		5				1		4	1	11	1
<i>Biology</i>							4				2	1	2	1	8	2
<i>Physics</i>							4						3		7	
<i>English</i>							4		1		3				8	
<i>Mathematics</i>					1		5				2				8	
<i>Social</i>							1		1						2	
<i>Psychology & Pedagogy</i>							3								3	
<i>Health & Physical Edu.</i>							1		1		1		1		4	
Technology Faculty							1		4		10		8		23	
<i>Civil Engineering</i>											3		3		9	
<i>Mechanical Engineering</i>											3		2		5	
<i>Electrical Engineering</i>							1		1		4		3		9	
Business Faculty					3		5		2		8				18	
<i>Management</i>					1		4		1		3				9	
<i>Accounting</i>									1		5				6	
<i>Economics</i>					2		1								3	
Jimma College of Agriculture					7		19	1	1		4		14	1	45	2
<i>Animal Science</i>					4		4						4	1	12	1
<i>Agricultural Engineering</i>					1		2						3		6	
<i>Agricultural Economics</i>							2	1	1		2		1		6	1
<i>Plant Sciences</i>					2		11				2		6		21	

University/Institute/College/Faculty Department	Professor		Associate Professor		Assistant Professor		Lecturer		Assistant Lecturer		Graduate Assistant		Others		Total	
	BS	F	BS	F	BS	F	BS	F	BS	F	BS	F	BS	F	BS	F
MAKELE UNIVERSITY			4		3		52	2	8	1	59	4	20	3	146	10
MAKELE UNIVERSITY COLLEGE			3		3		34	1	3		45	3	17	1	105	5
<i>Civil Engineering</i>					<i>1</i>				<i>1</i>		<i>6</i>		<i>3</i>		<i>11</i>	
<i>Industrial Engineering</i>							<i>3</i>				<i>4</i>		<i>2</i>		<i>9</i>	
<i>Mechanical Engineering</i>									<i>1</i>		<i>3</i>				<i>4</i>	
<i>Electrical Engineering</i>							<i>1</i>				<i>3</i>	<i>1</i>	<i>1</i>		<i>5</i>	<i>1</i>
<i>Applied Geology</i>					<i>1</i>		<i>2</i>				<i>4</i>	<i>1</i>			<i>7</i>	<i>1</i>
<i>Animal & Range Science</i>			<i>1</i>		<i>1</i>		<i>4</i>				<i>2</i>	<i>1</i>	<i>3</i>		<i>11</i>	<i>1</i>
<i>Dry land crop Science</i>			<i>1</i>				<i>4</i>	<i>1</i>			<i>1</i>		<i>3</i>	<i>1</i>	<i>9</i>	<i>2</i>
<i>Land Resource Management & Env.</i>			<i>1</i>				<i>3</i>				<i>1</i>		<i>3</i>		<i>8</i>	
<i>English</i>							<i>6</i>				<i>4</i>				<i>10</i>	
<i>Mathematics</i>							<i>4</i>				<i>5</i>				<i>9</i>	
<i>Biology</i>							<i>3</i>				<i>2</i>				<i>5</i>	
<i>Chemistry</i>							<i>1</i>				<i>2</i>		<i>1</i>		<i>4</i>	
<i>Physics</i>							<i>1</i>				<i>3</i>		<i>1</i>		<i>5</i>	
<i>SPSU</i>							<i>2</i>		<i>1</i>		<i>5</i>				<i>8</i>	
MAKELE BUSINESS COLLEGE			1				18	1	5	1	14	1	3	2	41	5
<i>Accounting</i>							<i>4</i>		<i>1</i>	<i>1</i>	<i>3</i>				<i>8</i>	<i>1</i>
<i>Economics</i>			<i>1</i>				<i>6</i>	<i>1</i>	<i>1</i>		<i>3</i>				<i>11</i>	<i>1</i>
<i>Management</i>							<i>7</i>				<i>3</i>				<i>10</i>	
<i>Secretarial Science and Office Management</i>							<i>1</i>				<i>1</i>		<i>3</i>	<i>2</i>	<i>5</i>	<i>2</i>
<i>Law</i>									<i>3</i>		<i>4</i>	<i>1</i>			<i>7</i>	<i>1</i>
TIGRAY ARTS COLLEGE													18		18	
<i>Fine Arts Department</i>													<i>5</i>		<i>5</i>	
<i>Music Department</i>													<i>8</i>		<i>8</i>	
<i>Theatrical Arts</i>													<i>3</i>		<i>3</i>	
<i>Common course</i>													<i>2</i>		<i>2</i>	
NAZARETH TECHNICAL COLLEGE					1		32		23	2	27	1	27	2	110	5
<i>Automotive Technology</i>							<i>2</i>		<i>2</i>		<i>3</i>		<i>4</i>		<i>11</i>	
<i>Construction Technology</i>							<i>3</i>		<i>5</i>	<i>1</i>	<i>2</i>		<i>3</i>		<i>13</i>	<i>1</i>
<i>Drafting and Surveying Technology</i>							<i>1</i>		<i>5</i>		<i>6</i>		<i>6</i>	<i>1</i>	<i>18</i>	<i>1</i>
<i>Electricity/Electronics Technology</i>							<i>7</i>		<i>3</i>		<i>2</i>		<i>5</i>	<i>1</i>	<i>17</i>	<i>1</i>
<i>Manufacturing Technology</i>							<i>5</i>		<i>3</i>				<i>4</i>		<i>12</i>	
<i>Surveying Technology</i>							<i>2</i>				<i>2</i>		<i>3</i>		<i>7</i>	
<i>Applied and Natural Science</i>							<i>4</i>		<i>4</i>		<i>8</i>		<i>2</i>		<i>18</i>	
<i>Language and Social Science .</i>							<i>3</i>		<i>1</i>	<i>1</i>	<i>4</i>	<i>1</i>			<i>8</i>	<i>2</i>
<i>Vocational Dep't</i>					<i>1</i>		<i>5</i>								<i>6</i>	
ETHIOPIAN CIVIL SERVICE COLLEGE					5		115	4	19	3	9	2	9	5	157	14
<i>Business & Economics Faculty</i>					<i>3</i>		<i>40</i>	<i>1</i>	<i>10</i>	<i>2</i>	<i>1</i>				<i>54</i>	<i>3</i>
<i>Faculty of Law</i>					<i>1</i>		<i>24</i>	<i>1</i>	<i>1</i>		<i>2</i>	<i>1</i>			<i>28</i>	<i>2</i>
<i>Technology Faculty</i>					<i>1</i>		<i>16</i>	<i>1</i>	<i>5</i>		<i>6</i>	<i>1</i>			<i>28</i>	<i>2</i>
<i>English</i>							<i>12</i>	<i>1</i>							<i>12</i>	<i>1</i>
<i>Computer Science</i>							<i>2</i>		<i>2</i>	<i>1</i>					<i>4</i>	<i>1</i>
<i>Library</i>							<i>3</i>						<i>9</i>	<i>5</i>	<i>12</i>	<i>5</i>
<i>Continuing Education</i>							<i>1</i>								<i>1</i>	
<i>Curr. & Educ. Technology</i>							<i>2</i>								<i>2</i>	
<i>Entrance exam center</i>							<i>2</i>								<i>2</i>	
<i>Physical Education & Sports</i>							<i>1</i>								<i>1</i>	
<i>Distance Education</i>							<i>7</i>		<i>1</i>						<i>8</i>	
<i>IFRGS</i>							<i>5</i>								<i>5</i>	
DEFENCE ENGINEERING COLLEGE							14		6		5	1	32	3	57	4
<i>Metallurgy</i>							<i>3</i>						<i>3</i>		<i>6</i>	
<i>Mechanical Engineering</i>							<i>2</i>								<i>2</i>	
<i>Manufacturing</i>									<i>2</i>		<i>3</i>				<i>5</i>	
<i>Mechanical Power</i>							<i>6</i>		<i>3</i>				<i>15</i>		<i>24</i>	
<i>Design Technology Department</i>							<i>3</i>		<i>1</i>		<i>2</i>	<i>1</i>	<i>14</i>	<i>3</i>	<i>20</i>	<i>4</i>
ETHIOPIA MASS MEDIA TRAINING INSTI					4		6	1	3				9	8	22	9
<i>Ethiopia Mass Media Training Institute</i>					<i>4</i>		<i>6</i>	<i>1</i>	<i>3</i>				<i>9</i>	<i>8</i>	<i>22</i>	<i>9</i>
MAICHEW TECHNIC COLLEGE							1		12		17				30	
<i>Automotive Technology</i>									<i>2</i>		<i>4</i>				<i>6</i>	
<i>Construction Technology</i>							<i>1</i>		<i>2</i>		<i>5</i>				<i>8</i>	
<i>Electrical Technology</i>									<i>3</i>		<i>3</i>				<i>6</i>	
<i>Manufacturing Technology</i>									<i>3</i>		<i>3</i>				<i>6</i>	
<i>General Courses</i>									<i>2</i>		<i>2</i>				<i>4</i>	
Grand Total	20		151	1	377	11	996	47	311	23	356	30	531	87	2742	199

* 1993 E.C. Data

Full time Expatriate Teaching Staff by Institution,
Department, Academic Rank and Sex
2001/02 (1994 E.C.) Academic Year First Semester

University/Institute/College/Faculty Department	Professor		Associate Professor		Assistant Professor		Lecturer		Assistant Lecturer		Graduate Assistant		Others		Total	
	BS	F	BS	F	BS	F	BS	F	BS	F	BS	F	BS	F	BS	F
ADDIS ABABA UNIVERSITY	15		16		9	1	2								42	1
College of Social Science	2		3		1										6	
<i>Geography</i>	1		1												2	
<i>History</i>			1												1	
<i>Philosophy</i>	1														1	
<i>Sociology & Social Admin.</i>			1		1										2	
Faculty of Business & Economics			1		2										3	
<i>Accounting</i>					1										1	
<i>Management & Public Adm.</i>			1		1										2	
Faculty of Education					1										1	
<i>Curriculum & Instruction</i>					1										1	
Faculty of Medicine	5		2		2										9	
<i>Anatomy</i>	2														2	
<i>Biochemistry</i>	2														2	
<i>Community Health</i>					1										1	
<i>Pathology</i>	1														1	
<i>Pharmacology</i>			1												1	
<i>Physiology</i>					1										1	
<i>Surgery</i>			1												1	
Faculty of Science	3		4		1										8	
<i>Chemistry</i>			3												3	
<i>Mathematics</i>	2														2	
<i>Physics</i>	1		1		1										3	
Faculty of Technology	2		1												3	
<i>Civil Engineering</i>	1														1	
<i>Electrical Engineering</i>	1		1												2	
Institute of Language Studies							1								1	
<i>Foreign Language and Literature</i>							1								1	
School of Pharmacy	2		3		1	1	1								7	1
Demographic Training and Research Center			2		1										3	
Institute of Ethiopian Studies	1														1	
DEBUB UNIVERSITY			2	1	4		9	5							15	6
Awassa College of Agriculture							3	3							3	3
<i>Home Science and Technology</i>							3	3							3	3
Wondo Genet College of Forestry			2	1			4	2							6	3
<i>Basic Science</i>							2	2							2	2
<i>Silviculture and Extension</i>				1	1		1								2	1
<i>Forestry Management and Utilization</i>				1			1								2	
Dilla Teacher Education and Health Sciences College					4		2								6	
Faculty of Education					4		2								6	
<i>Chemistry</i>					1										1	
<i>History</i>							1								1	
<i>Mathematics</i>							1								1	
<i>Physics</i>					3										3	
BAHIR DAR UNIVERSITY					1		5								6	
Bahir Dar Teachers College					1		4								5	
<i>Business</i>							3								3	
<i>Mathematics</i>					1										1	
<i>Physics</i>							1								1	
Bahir Dar Polytechnic Institute							1								1	
<i>Civil Engineering</i>							1								1	
GONDER COLLEGE OF MEDICAL SCIENCES					4	3	1								5	3
<i>Gondar Medical Science</i>					4	3	1								5	3
ALEMAYA UNIVERSITY OF AGRICULTURE	14		5		3										22	
Faculty of Agriculture	12		5		1										18	
<i>Agricultural Engineering</i>	2		2												4	
<i>Animal Science</i>	2		2		1										5	
<i>Plant Science</i>	8		1												9	
Faculty of Education	2				2										4	
<i>Chemistry</i>					2										2	
<i>Physics</i>	2														2	

University/Institute/College/Faculty Department	Professor		Associate Professor		Assistant Professor		Lecturer		Assistant Lecturer		Graduate Assistant		Others		Total	
	BS	F	BS	F	BS	F	BS	F	BS	F	BS	F	BS	F	BS	F
AWASSA COLLEGE OF TEACHER EDUCATION							1		1	1					2	1
English									1	1					1	1
Physics							1								1	
ABBIYI ADDI COLLEGE OF TEACHER EDUCATION									1	1					1	1
English									1	1					1	1
GONDAR COLLEGE OF TEACHER EDUCATION									2	1					2	1
English									2	1					2	1
ARBA MINCH WATER TECHNOLOGY INSTITUT	1				6		4								11	
Civil Engineering							1								1	
Electrical Engineering					1		2								3	
Hydraulic Engineering	1				2										3	
Irrigation Engineering							1								1	
Mechanical Engineering					3										3	
JIMMA UNIVERSITY	4		2		9		6	2							21	2
Jimma Institute of Health Sciences	3		2				1	1							6	1
Medical School	3		2												5	
Preclinical Health Prog.	3		2												5	
Public Health							1	1							1	1
Nursing School							1	1							1	1
Technology Faculty					9		3								12	
Civil Engineering					5		1								6	
Mechanical Engineering					2		1								3	
Electrical Engineering					2		1								3	
Business Faculty	1						2	1							3	1
Management							2	1							2	1
Accounting	1														1	
MAKELE UNIVERSITY			3		1		6								10	
MAKELE UNIVERSITY COLLEGE			3		1		6								10	
Civil Engineering							3								3	
Industrial Engineering					1		2								3	
Mechanical Engineering							1								1	
Applied Geology			3												3	
TIGRAY ARTS COLLEGE													1		1	
Music Department													1		1	
ETHIOPIAN CIVIL SERVICE COLLEGE	2		2	1	1		6	2							11	3
Business & Economics Faculty	1		2	1	1		4	2							8	3
Faculty of Law	1														1	
Technology Faculty							2								2	
MAICHEW TECHNIC COLLEGE										1					1	
Manufacturing Technology										1					1	
Grand Total	36		30	2	38	4	40	9	4	3	1		1		150	18

* 1993 E.C. Data

Full time Teaching Staff by Institution,
Department, Academic Rank and Sex
2001/02 (1994 E.C.) Academic Year First Semester

University/Institute/College/Faculty Department	Professor		Associate Professor		Assistant Professor		Lecturer		Assistant Lecturer		Graduate Assistant		Others		Total	
	BS	F	BS	F	BS	F	BS	F	BS	F	BS	F	BS	F	BS	F
ADDIS ABABA UNIVERSITY	34		136	1	207	9	192	17	70	7	16	4	224	45	879	83
College of Social Science	4		16		14		10		3	1			2		49	1
<i>Geography</i>	1		3		2		3						2		11	
<i>History</i>	1		5		3		2		2						13	
<i>Philosophy</i>	1		1		1		3								6	
<i>Poli. Scie. & Intrna.Relations</i>			6		5		1								12	
<i>Sociology & Social Adm.</i>	1		1		3		1		1	1					7	1
Faculty of Business & Economics	1		4		11		21	2	11		4	2			52	4
<i>Accounting</i>					2		7	1	6						15	1
<i>Economics</i>	1		2		6		6	1	3		2	1			20	2
<i>Management & Public Adm.</i>			2		3		8		2		2	1			17	1
Faculty of Education			13		8		15	1	4		1		1		42	1
<i>Business Administration</i>			1				4								5	
<i>Curriculum & Instruction</i>			2		4		3		3		1		1		14	
<i>Educational Administration</i>			3		2		3		1						9	
<i>Educational Psychology</i>			7		2		5	1							14	1
Faculty of Law	1		1		4		6		2	1					14	1
Faculty of Medicine	8		39	1	55	4	13	2	11	3	4		57	17	187	27
<i>Anatomy</i>	2		1		4	1					1		1		9	1
<i>Anaesthesiology</i>					2										2	
<i>Biochemistry</i>	2		1										4	1	7	1
<i>Community Health</i>	1		4		5		2								12	
<i>Internal Medicine</i>			8	1	9		2						3		22	1
<i>Microbiology and Parasitology</i>	1		1		2	1	1						4	2	9	3
<i>Obsterics & Gynaecology</i>			2		8	1									10	1
<i>Ophthalmology</i>			1		4		1								6	
<i>Orthopaedics</i>					2								1		3	
<i>Paediatrics</i>	1		6		3										10	
<i>Pathology</i>	1		2		2	1							1		6	1
<i>Pharmacology</i>			2								1		2	1	5	1
<i>Physiology</i>			3		3		1						2		9	
<i>Psychiatry</i>			1		2										3	
<i>Radiology</i>			1		2										3	
<i>Surgery</i>			6		7								1		14	
<i>School of Medical Laboratory Technology</i>							6	2	11	3	2		38	13	57	18
Faculty of Science	10		24		45	1	35	2	14		2		24	10	154	13
<i>Biology</i>	3		7		14		4	1	1				7	3	36	4
<i>Chemistry</i>	2		7		5		5		3				8	6	30	6
<i>Geology & Geophysics</i>	1		5		9		3		2				1		21	
<i>Mathematics</i>	2		3		6	1	9		6		1		1		28	1
<i>Physics</i>	1		1		7		7		2				3		21	
<i>Statistics</i>	1				2		6	1			1				10	1
<i>Geop hysical Observatory</i>			1		2		1						4	1	8	1
Faculty of Technology	4		15		21		30	1	10		4	1	23		107	2
<i>Architecture and Urban Planning</i>			1		1		9	1			2				13	1
<i>Building Technology</i>							5		1				3		9	
<i>Chemical Engineering</i>			1		2		3		1				1		8	
<i>Civil Engineering</i>	1		3		9		3		2		1	1	6		25	1
<i>Electrical Engineering</i>	3		4		6		6						5		24	
<i>Material Research & Testing Department</i>			1				2		1				2		6	
<i>Mechanical Engineering</i>			5		3		2		5		1		6		22	
Faculty of Veterinary Medicine			2		11	1	11		4	1			20	2	48	4
<i>Anatomy & Embryology</i>							1		2	1			2	1	5	2
<i>Basic Science</i>					1		2						2		5	
<i>Clinical Studies</i>					3	1	3						5		11	1
<i>Microbiology,Infection desessie & Vet.pub. Health</i>					3				1				3		7	
<i>Pathology & Parasitology</i>			2		2		1						4	1	9	1
<i>Physiology</i>					1		2		1				1		5	
<i>Zootechnology</i>					1		2						3		6	
Institute of Language Studies	1		6		21		24	5					2	1	54	6

University/Institute/College/Faculty Department	Professor		Associate Professor		Assistant Professor		Lecturer		Assistant Lecturer		Graduate Assistant		Others		Total	
	BS	F	BS	F	BS	F	BS	F	BS	F	BS	F	BS	F	BS	F
<i>Ethiopian Language and Literature</i>			3		2		7	1							12	1
<i>Foreign Language and Literature</i>			2		16		13	4					2	1	33	5
<i>Linguistics</i>	1		1		2										4	
<i>Theatre Arts</i>					1		4								5	
School of Information Science for Africa					2	1	6	1	3	1	1	1	1		13	4
School of Graduate Studies			1												1	
School of Pharmacy	3		5		2	1	4		6				3		23	1
Physical Education & Sports													13		13	
Institute of Development Research			1		3		3								7	
Demographic Training and Research Center			2		1		2								5	
Centre for Res. Tr. and Infor. for Women Dev. (1	1	3	3							4	4
Institute of Educational Research			2		3		4								9	
Institute of Ethiopian Studies	2		1		2		2		1				5		13	
Institute of Patobiology (IPB)			4		3		3		1				10	5	21	5
University Library													21	4	21	4
School of Arts and Design													16	1	16	1
Yared Music School													26	5	26	5
DEBUB UNIVERSITY			11	1	24		104	13	25	2	35	2	47	6	246	24
Awassa College of Agriculture			3		7		30	6	6	1	5		20	3	71	10
<i>Agricultural Eng. and Mechan.</i>					1		7		5		1		5		19	
<i>Animal Production and Range Land Management</i>			3		3		9	1			2		6		23	1
<i>Home Science and Technology</i>							7	5	1	1			2	2	10	8
<i>Plant Production and Dry Land Farming</i>					3		7				2		7	1	19	1
Wondo Genet College of Forestry			8	1	1		20	5			7		7		43	6
<i>Basic Science</i>			1				6	3			2		3		12	3
<i>Silviculture and Extension</i>			2	1	1		8	2			2		1		14	3
<i>Forestry Management and Utilization</i>			5				6				3		3		17	
Dilla Teacher Education and Health Sciences College					16		54	2	19	1	23	2	20	3	132	8
Faculty of Education					9		48	2	3	1	15	1	9	2	84	6
<i>Amharic</i>							5	1			1				6	1
<i>Biology</i>					1		9	1	1	1	2		3	1	16	3
<i>Chemistry</i>					4		5				3		3		15	
<i>English</i>							1				4				5	
<i>Geography</i>							6		1		1		1	1	9	1
<i>History</i>							4		1		2	1			7	1
<i>Mathematics</i>							6				1				7	
<i>Pedagogy</i>					1		6								7	
<i>Physics</i>					3		6				1		2		12	
Faculty of Health Sciences					7		6		16		8	1	11	1	48	2
<i>Health Officer</i>					7		1		4						12	
<i>Environmental Health</i>									3		2		3		8	
<i>Laboratory Technoloy</i>									1		2		5		8	
<i>Public Health Nursing</i>							1		4		3	1	3	1	11	2
<i>Biomedical & Behavioural Science</i>							4		4		1				9	
BAHIR DAR UNIVERSITY					22		75	1	15		40	2	18		170	3
Bahir Dar Teachers College					18		45	1	3		21	2	8		95	3
<i>Business</i>					1		3				10	1			14	1
<i>Amaharic</i>					3		2				1	1			6	1
<i>Biology</i>					1		4		2		2		3		12	
<i>Chemistry</i>					1		4				2		2		9	
<i>English</i>							4								4	
<i>Geography</i>					3		4								7	
<i>History</i>					1		2				3				6	
<i>Mathematics</i>					2		11								13	
<i>Pedagogy</i>					3		7	1	1						11	1
<i>Physics</i>					3		4						1		8	
<i>Law</i>											3				3	
<i>Physical Edu.</i>													2		2	
Bahir Dar Polytechnic Institute					4		30		12		19		10		75	
<i>Textile Engineering</i>							5								5	
<i>Civil Engineering</i>							5		6		5		5		21	
<i>Electrical Engineering</i>							6		2		6				14	
<i>Chemical Engineering</i>					1		7		3		3				14	
<i>Mechanical Engineering</i>					3		5		1		3		5		17	
<i>Social, Applied and Natural Science</i>																
<i>Industrial</i>							2				2				4	
GONDER COLLEGE OF MEDICAL SCIENC			9		27	5	17	1	23		12	1	16	3	104	10
<i>Gondar Medical Science</i>			9		27	5	17	1	23		12	1	16	3	104	10
ALEMAYA UNIVERSITY	14		11		19		57	2	14	2	27	5	20	1	162	10
Faculty of Agriculture	12		10		12		7		1	1	7		9		58	1

University/Institute/College/Faculty Department	Professor		Associate Professor		Assistant Professor		Lecturer		Assistant Lecturer		Graduate Assistant		Others		Total	
	BS	F	BS	F	BS	F	BS	F	BS	F	BS	F	BS	F	BS	F
<i>Agricultural Engineering</i>	2		3		3		1				2				11	
<i>Animal Science</i>	2		3		3		4				2				14	
<i>Plant Science</i>	8		4		6		2		1	1	3		9		33	1
Faculty of Education	2		1		6		40	2	3		7		5		64	2
<i>Biology</i>			1				7	2			1		2		11	2
<i>Chemistry</i>					4		5				1		3		13	
<i>English</i>					1		7		1						9	
<i>Mathematics</i>							7				1				8	
<i>Physics</i>	2				1		5				1				9	
<i>Pedagogy</i>							3								3	
<i>Geography</i>							4				1				5	
<i>History</i>									1		2				3	
<i>Physical Education</i>							2		1						3	
Faculty of Health					1		10		10	1	13	5	6	1	40	7
<i>Environmental Health</i>							1		2		3		1		7	
<i>Medical Laboratory</i>									5		1	1	2		8	1
<i>Public Health</i>					1		9		1		5	2			16	2
<i>Nursing</i>									2	1	4	2	3	1	9	4
AMBO COLLEGE OF AGRICULTURE	1				3		18		10	3	2		11	1	45	4
<i>Basic Science</i>					1		4		3				2		10	
<i>Plant Science</i>							4		7	3	2				13	3
<i>Animal Science</i>							4						3		7	
<i>Agricultural Engineering</i>	1				1		2						4	1	8	1
<i>Agricultural Economics & Extension</i>					1		4						2		7	
ADDIS ABABA COLLEGE OF COMMERCE					2		50	6	4	1	12	2	7	2	75	11
<i>Accounting</i>					1		6		3	1	2	1			12	2
<i>Banking&Finance</i>							6	1			3				9	1
<i>Secretarial Sc. & Office Mgt.</i>							8	1	1		2	1	3	2	14	4
<i>Purchasing & Supply Management</i>							4				5				9	
<i>Department of BIS</i>							2						3		5	
<i>Common Course</i>					1		24	4					1		26	4
KOTEBE COLLEGE OF TEACHER EDUCATION			1		23		47	2	1		8		9	2	89	4
<i>Biology</i>					5		2				2		3	2	12	2
<i>Chemistry</i>					1		3				3		2		9	
<i>Ethiopian Language</i>					1		5	1							6	1
<i>Geography</i>					2		6								8	
<i>Health and Physical Education</i>					4		2		1		1				8	
<i>History</i>					3		2								5	
<i>Mathematics</i>							8								8	
<i>Physics</i>							5				2		2		9	
<i>Phyloseohy, Economie & Civics</i>					1		3	1							4	1
<i>English</i>			1		3		5								9	
<i>Education</i>					3		6								9	
<i>Art and Music</i>													2		2	
AWASSA COLLEGE OF TEACHER EDUCATION					2		45		4	2	1		7	1	59	3
<i>Education</i>							8								8	
<i>Amharic</i>							5								5	
<i>English</i>							5		2	2					7	2
<i>Mathematics</i>							6								6	
<i>Biology</i>					1		4						2	1	7	1
<i>Physics</i>							4		2				2		8	
<i>Chemistry</i>							5						2		7	
<i>Geography</i>							3								3	
<i>History</i>					1		3								4	
<i>Health and Physical Education</i>							2				1		1		4	
ABBIYI ADDI COLLEGE OF TEACHER EDUCATION							9		19	1	11	2	6		45	3
<i>Ethiopian Languages and Literature</i>									3		1	1	3		7	1
<i>Health and Physical Education</i>									2						2	
<i>English</i>									4	1	1				5	1
<i>Natural Science</i>							6		1		4		2		13	
<i>Social Science</i>									5		2	1			7	1
<i>Education</i>							2		2		1		1		6	
<i>Mathematics</i>							1		2		2				5	

University/Institute/College/Faculty Department	Professor		Associate Professor		Assistant Professor		Lecturer		Assistant Lecturer		Graduate Assistant		Others		Total	
	BS	F	BS	F	BS	F	BS	F	BS	F	BS	F	BS	F	BS	F
GONDAR COLLEGE OF TEACHER EDUCATION							31		7	1	3		2		43	1
<i>Amharic</i>							4								4	
<i>English</i>							2		3	1	1				6	1
<i>Mathematics</i>							6								6	
<i>Biology</i>							4								4	
<i>Chemistry</i>							4								4	
<i>Physics</i>							3								3	
<i>Geography</i>							2		1						3	
<i>History</i>							3		2						5	
<i>Education</i>							3		1		2				6	
<i>Health and Physical Education</i>													2		2	
ARBA MINCH WATER TECHNOLOGY INSTITUTE	1				7		38		2		22	1			70	1
<i>Basic Science</i>							15				7	1			22	1
<i>Civil Engineering</i>							5				6				11	
<i>Electrical Engineering</i>					1		4		2		3				10	
<i>Environmental Engineering</i>							3								3	
<i>Hydraulic Engineering</i>	1				3		2				3				9	
<i>Irrigation Engineering</i>							4				1				5	
<i>Mechanical Engineering</i>					3		5				2				10	
JIMMA COLLEGE OF TEACHER EDUCATION							35		6		2		6		49	
<i>A/Oromo</i>							3		1						4	
<i>English</i>							1		2						3	
<i>Amaharic</i>							3								3	
<i>Education</i>							8						2		10	
<i>Geography</i>							3								3	
<i>History</i>							2		1		1				4	
<i>Civics</i>											1				1	
<i>Biology</i>							3								3	
<i>Chemistry</i>							4						1		5	
<i>Physical</i>							2		1				1		4	
<i>Mathematics</i>							2								2	
<i>Physical Edu.</i>									1				2		3	
<i>ANFE</i>							4								4	
JIMMA UNIVERSITY	4		4		64	1	86	5	44	1	48	3	43	5	293	15
Jimma Institute of Health Sciences	3		4		43	1	29	3	34	1	17	2	11	2	141	9
Medical School	3		4		39	1	23	1	20		12		9	2	110	4
<i>Cilical Prog.</i>					23		7	1	5						35	1
<i>Preclinical Health Prog.</i>	3		2		8		7		4		5		4	1	33	1
<i>Community Health programme</i>			2		8	1	3		5		1				19	1
<i>Pharmacy School</i>							2		4		4		2		12	
<i>Laboratory Technology School</i>							4		2		2		3	1	11	1
Public Health					4		6	2	14	1	5	2	2		31	5
<i>Public Health School</i>									1						1	
<i>Nursing School</i>					2		5	2	9	1	3	2			19	5
<i>Environmental Health</i>					2		1		4		2		2		11	
Sciences & Liberal Art Faculty					2		27		3		9	1	10	2	51	3
<i>Chemistry</i>					1		5				1		4	1	11	1
<i>Biology</i>							4				2	1	2	1	8	2
<i>Physics</i>							4						3		7	
<i>English</i>							4		1		3				8	
<i>Mathematics</i>					1		5				2				8	
<i>Social</i>							1		1						2	
<i>Psychology & Pedagogy</i>							3								3	
<i>Health & Physical Edu.</i>							1		1		1		1		4	
Technology Faculty					9		4		4		10		8		35	
<i>Civil Engineering</i>					5		1		3		3		3		15	
<i>Mechanical Engineering</i>					2		1				3		2		8	
<i>Electrical Engineering</i>					2		2		1		4		3		12	
Business Faculty	1				3		7	1	2		8				21	1
<i>Management</i>					1		6	1	1		3				11	1
<i>Accounting</i>	1								1		5				7	
<i>Economics</i>					2		1								3	
Jimma College of Agriculture					7		19	1	1		4		14	1	45	2
<i>Animal Science</i>					4		4						4	1	12	1
<i>Agricultural Engineering</i>					1		2						3		6	
<i>Agricultural Economics</i>							2	1	1		2		1		6	1
<i>Plant Sciences</i>					2		11				2		6		21	

University/Institute/College/Faculty Department	Professor		Associate Professor		Assistant Professor		Lecturer		Assistant Lecturer		Graduate Assistant		Others		Total	
	BS	F	BS	F	BS	F	BS	F	BS	F	BS	F	BS	F	BS	F
MAKELE UNIVERSITY			7		4		58	2	8	1	59	4	20	3	156	10
MAKELE UNIVERSITY COLLEGE			6		4		40	1	3		45	3	17	1	115	5
<i>Civil Engineering</i>					1		3		1		6		3		14	
<i>Industrial Engineering</i>					1		5				4		2		12	
<i>Mechanical Engineering</i>							1		1		3				5	
<i>Electrical Engineering</i>							1				3	1	1		5	1
<i>Applied Geology</i>			3		1		2				4	1			10	1
<i>Animal & Range Science</i>			1		1		4				2	1	3		11	1
<i>Dry land crop Science</i>			1				4	1			1		3	1	9	2
<i>Land Resource Management & Env.</i>			1				3				1		3		8	
<i>English</i>							6				4				10	
<i>Mathematics</i>							4				5				9	
<i>Biology</i>							3				2				5	
<i>Chemistry</i>							1				2		1		4	
<i>Physics</i>							1				3		1		5	
<i>SPSU</i>							2		1		5				8	
MAKELE BUSINESS COLLEGE			1				18	1	5	1	14	1	3	2	41	5
<i>Accounting</i>							4		1	1	3				8	1
<i>Economics</i>			1				6	1	1		3				11	1
<i>Management</i>							7				3				10	
<i>Secretarial Science and Office Management</i>							1				1		3	2	5	2
<i>Law</i>									3		4	1			7	1
TIGRAY ARTS COLLEGE													19		19	
<i>Fine Arts Department</i>													5		5	
<i>Music Department</i>													9		9	
<i>Theatrical Arts</i>													3		3	
<i>Common course</i>													2		2	
NAZARETH TECHNICAL COLLEGE					1		32		23	2	27	1	27	2	110	5
<i>Automotive Technology</i>							2		2		3		4		11	
<i>Construction Technology</i>							3		5	1	2		3		13	1
<i>Drafting and Surveying Technology</i>							1		5		6		6	1	18	1
<i>Electricity/Electronics Technology</i>							7		3		2		5	1	17	1
<i>Manufacturing Technology</i>							5		3				4		12	
<i>Surveying Technology</i>							2				2		3		7	
<i>Applied and Natural Science</i>							4		4		8		2		18	
<i>Language and Social Science .</i>							3		1	1	4	1			8	2
<i>Vocational Dep't</i>					1		5								6	
ETHIOPIAN CIVIL SERVICE COLLEGE	2		2	1	6		121	6	19	3	9	2	9	5	168	17
<i>Business & Economics Faculty</i>	1		2	1	4		44	3	10	2	1				62	6
<i>Faculty of Law</i>	1				1		24	1	1		2	1			29	2
<i>Technology Faculty</i>					1		18	1	5		6	1			30	2
<i>English</i>							12	1							12	1
<i>Computer Science</i>							2		2	1					4	1
<i>Library</i>							3						9	5	12	5
<i>Continuing Education</i>							1								1	
<i>Curr.& Educ. Technology</i>							2								2	
<i>Entrance exam center</i>							2								2	
<i>Physical Education & Sports</i>							1								1	
<i>Distance Education</i>							7		1						8	
<i>IFRGS</i>							5								5	
<i>Others</i>																
DEFENCE ENGINEERING COLLEGE							14		6		5	1	32	3	57	4
<i>Metallurgy</i>							3						3		6	
<i>Mechanical Engineering</i>							2								2	
<i>Manufacturing</i>									2		3				5	
<i>Mechanical Power</i>							6		3				15		24	
<i>Design Technology Department</i>							3		1		2	1	14	3	20	4
ETHIOPIA MASS MEDIA TRAINING INSTII					4		6	1	3				9	8	22	9
<i>Ethiopia Mass Media Training Institute</i>					4		6	1	3				9	8	22	9
MAICHEW TECHNIC COLLEGE							1		12		18				31	
<i>Automotive Technology</i>									2		4				6	
<i>Construction Technology</i>							1		2		5				8	
<i>Electrical Technology</i>									3		3				6	
<i>Manufacturing Technology</i>									3		4				7	
<i>General Courses</i>									2		2				4	
Grand Total	56		181	3	415	15	1036	56	315	26	357	30	532	87	2892	217

* 1993 E.C. Data

Full time Teaching Staff by Institution, Department, Academic Level and Sex
2001/02 (1994 E.C.) Academic Year First Semester

Ethiopian

University/Institute/College/Faculty Department	Diploma		Bachlor Degree		Masters Degree		M.D/D.V Degree		Doctorate Degree		Others		Total	
	BS	F	BS	F	BS	F	BS	F	BS	F	BS	F	BS	F
	UNITY COLLEE			105	6	55	6			11	1			171
ETHIOPIAN ADVENTIST COLLEGE			5		4				1				10	
AGRO-TECHNICAL TRAINING COLLEGE	12	2	10		2		2		1				27	2
SELAM NURSES COLLEGE	3	3	6	3	3	1			1				13	7
MICROLINK INFORMATION TECH. COLLEGE			39	5	21	1			1				61	6
ROYAL COLLEGE			13		4	1			2		1		20	1
AFRICA BEZA COLLEGE			12		4								16	
HILCOE COMPUTER TECHNOLOGY	19												19	
TOP COLLEGE			23		6								29	
NEW MILLENNIUM COLLEGE	3		19		4								26	
ADDIS COLLEGE			16										16	
TOTAL	37	5	248	14	103	9	2		17	1	1		408	29

Expatriate

University/Institute/College/Faculty Department	Diploma		Bachlor Degree		Masters Degree		M.D/D.V Degree		Doctorate Degree		Others		Total	
	BS	F	BS	F	BS	F	BS	F	BS	F	BS	F	BS	F
	UNITY COLLEE					1								1
ETHIOPIAN ADVENTIST COLLEGE	1		2	2	4	2			2				9	4
AGRO-TECHNICAL TRAINING COLLEGE					2						1		3	
TOTAL	1		2	2	7	2			2		1		13	4

Ethiopian and Expatriate

University/Institute/College/Faculty Department	Diploma		Bachlor Degree		Masters Degree		M.D/D.V Degree		Doctorate Degree		Others		Total	
	BS	F	BS	F	BS	F	BS	F	BS	F	BS	F	BS	F
	UNITY COLLEE			105	6	56	6			11	1			172
ETHIOPIAN ADVENTIST COLLEGE	1		7	2	8	2			3				19	4
AGRO-TECHNICAL TRAINING COLLEGE	12	2	10		4		2		1		1		30	2
SELAM NURSES COLLEGE	3	3	6	3	3	1			1				13	7
MICROLINK INFORMATION TECH. COLLEGE			39	5	21	1			1				61	6
ROYAL COLLEGE			13		4	1			2		1		20	1
AFRICA BEZA COLLEGE			12		4								16	
HILCOE COMPUTER TECHNOLOGY	19												19	
TOP COLLEGE			23		6								29	
NEW MILLENNIUM COLLEGE	3		19		4								26	
ADDIS COLLEGE			16										16	
TOTAL	16	5	192	16	100	11	2		19	1	2		421	33

Full time Ethiopian Teaching Staff by Institution, Department, Academic Rank and Sex
2001/02 (1994 E.C.) Academic Year First Semester

Ethiopian

University/Institute/College/Faculty Department	Professor		Associate Professor		Assistant Professor		Lecturer		Assistant Lecturer		Graduate Assistant		Others		Total	
	BS	F	BS	F	BS	F	BS	F	BS	F	BS	F	BS	F	BS	F
UNITY COLLEE			5		7	1	55	6	15	1	89	5			171	13
ETHIOPIAN ADVENTIST COLLEGE					2		8								10	
AGRO-TECHNICAL TRAINING COLLEGE					1		13				1		12	2	27	2
SELAM NURSES COLLEGE			2		2	1	6	3					3	3	13	7
MICROLINK INFORMATION TECH. COLLEGE			1				22	1	13	1	25	4			61	6
ROYAL COLLEGE							1						19	1	20	1
AFRICA BEZA COLLEGE*							16								16	
HILCOE COMPUTER TECHNOLOGY													19		19	
TOP COLLEGE*															29	
NEW MILLENNIUM COLLEGE*															26	
ADDIS COLLEGE													16		16	
TOTAL			8		12	2	121	10	28	2	115	9	69	6	408	29

Expatriate

University/Institute/College/Faculty Department	Professor		Associate Professor		Assistant Professor		Lecturer		Assistant Lecturer		Graduate Assistant		Others		Total	
	BS	F	BS	F	BS	F	BS	F	BS	F	BS	F	BS	F	BS	F
UNITY COLLEE							1								1	
ETHIOPIAN ADVENTIST COLLEGE					4	1	5	3							9	4
AGRO-TECHNICAL TRAINING COLLEGE							2						1		3	
TOTAL					4	1	8	3					1		13	4

Ethiopian and Expatriate

University/Institute/College/Faculty Department	Professor		Associate Professor		Assistant Professor		Lecturer		Assistant Lecturer		Graduate Assistant		Others		Total	
	BS	F	BS	F	BS	F	BS	F	BS	F	BS	F	BS	F	BS	F
UNITY COLLEE			5		7	1	56	6	15	1	89	5			172	13
ETHIOPIAN ADVENTIST COLLEGE					6	1	13	3							19	4
AGRO-TECHNICAL TRAINING COLLEGE					1		15				1		13	2	30	2
SELAM NURSES COLLEGE			2		2	1	6	3					3	3	13	7
MICROLINK INFORMATION TECH. COLLEGE			1				22	1	13	1	25	4			61	6
ROYAL COLLEGE							1						19	1	20	1
AFRICA BEZA COLLEGE							16								16	
HILCOE COMPUTER TECHNOLOGY													19		19	
TOP COLLEGE															29	
NEW MILLENNIUM COLLEGE*															26	
ADDIS COLLEGE													16		16	
TOTAL			8		16	3	129	13	28	2	115	9	70	6	421	33

* Data not available by Academic Rank.

ADMINISTRATIVE AND GENERAL SERVICE STAFF

Definition of concepts

Administrative and General Service Staff

These are employees engaged in services that involve water supply, telephone, electricity, finance, administration, transport, publication, custody, health, students' cafeteria, maintenance, bookstore, archives, and so on. They are either full-time or part-time employees who do not participate directly in teaching or research and therefore, do not have academic rank.

Administrative and General Service Staff
by Institution Type of Occupation, Level of Education and Sex
2001/02 (1994 E.C)

University/Institute/College/Faculty Department	Level of Education		Certificate and Above		Total		
	Type of Occupation	12 th Grade and below		BS	F	BS	F
		BS	F				
ADDIS ABABA UNIVERSITY* (All institution)	Professional Service			21	7	21	7
	Sub-Professional Service	118	42	141	42	259	84
	Administrative Service	11	2	37	14	48	16
	Clerical & Financial Serv.	211	142	181	145	392	287
	Trade & Craft Service	269	84	15	3	284	87
	Manual & Custodial Serv.	576	443	19	16	595	459
	Total	1185	713	414	227	1599	940
AWASSA COLLEGE OF AGRICULTURE*	Professional Service						
	Sub-Professional Service	14	2	4		18	2
	Administrative Service	3	2	2		5	2
	Clerical & Financial Serv.	39	22	9	4	48	26
	Trade & Craft Service	62	25	6		68	25
	Manual & Custodial Serv.	120	43			120	43
	Total	238	94	21	4	259	98
BAHIR DAR UNIVERSITY	Professional Service	3	2	5	3	8	5
	Sub-Professional Service	9	2	11	2	20	4
	Administrative Service	7	1	11	1	18	2
	Clerical & Financial Serv.	68	53	8	7	76	60
	Trade & Craft Service	94	64			94	64
	Manual & Custodial Serv.	112	36			112	36
	Total	293	158	35	13	328	171
GONDAR COLLEGE OF MEDICAL SCIENCES*	Professional Service			13		13	
	Sub-Professional Service	28	15	116	56	144	71
	Administrative Service	7	2	3		10	2
	Clerical & Financial Serv.	79	60	8	4	87	64
	Trade & Craft Service	121	73			121	73
	Manual & Custodial Serv.	209	97			209	97
	Total	444	247	140	60	584	307
ALEMAYA UNIVERSITY*	Professional Service			2	2	2	2
	Sub-Professional Service	40	8	19	5	59	13
	Administrative Service	3		9	1	12	1
	Clerical & Financial Serv.	51	20	17	13	68	33
	Trade & Craft Service	115	28			115	28
	Manual & Custodial Serv.	292	95			292	95
	Total	501	151	47	21	548	172
AMBO COLLEGE OF AGRICULTURE	Professional Service			2		2	
	Sub-Professional Service	5	2	5	1	10	3
	Administrative Service	1		7	3	8	3
	Clerical & Financial Serv.	22	11	10	6	32	17
	Trade & Craft Service	33	11			33	11
	Manual & Custodial Serv.	111	29			111	29
	Total	172	53	24	10	196	63
JIMMA COLLEGE OF AGRICULTURE	Professional Service	1	1	3		4	1
	Sub-Professional Service	10	6	5	1	15	7
	Administrative Service			4	1	4	1
	Clerical & Financial Serv.	18	8	6	4	24	12
	Trade & Craft Service	42	24			42	24
	Manual & Custodial Serv.	110	19			110	19
	Total	181	58	18	6	199	64
ADDIS ABABA COLLEGE OF COMMERCE	Professional Service			4	3	4	3
	Sub-Professional Service	1		5	1	6	1
	Administrative Service	2		7	3	9	3
	Clerical & Financial Serv.	30	23	16	9	46	32
	Trade & Craft Service	8				8	
	Manual & Custodial Serv.	53	26			53	26
	Total	94	49	32	16	126	65
KOTEBE COLLEGE OF TEACHER EDUCATION	Professional Service			7	1	7	1
	Sub-Professional Service	2	2			2	2
	Administrative Service	1	1	6	3	7	4
	Clerical & Financial Serv.	37	25	24	17	61	42
	Trade & Craft Service	88	51	11	6	99	57
	Manual & Custodial Serv.	61	39			61	39
	Total	189	118	48	27	237	145

University/Institute/College/Faculty Department	Level of Education		Certificate and Above		Total		
	Type of Occupation	12 th Grade and below		BS	F	BS	F
		BS	F				
ARBA MINCH WATER TECHNOLOGY INSTITUTE	Professional Service				3		3
	Sub-Professional Service	4	1	10	2	14	3
	Administrative Service	1		7		8	
	Clerical & Financial Serv.	34	7	3	1	37	8
	Trade & Craft Service	57	33			57	33
	Manual & Custodial Serv.	114	50			114	50
	Total	210	91	23	3	233	94
ETHIOPIAN CIVIL SERVICE COLLEGE	Professional Service			6	1	6	1
	Sub-Professional Service	1	1	20	5	21	6
	Administrative Service	1		4	2	5	2
	Clerical & Financial Serv.	27	16	42	32	69	48
	Trade & Craft Service	34	18			34	18
	Manual & Custodial Serv.	59	42			59	42
	Total	122	77	72	40	194	117
JIMMA HEALTH SCIENCE INSTITUTE	Professional Service	1		11		12	
	Sub-Professional Service	16	6	9	2	25	8
	Administrative Service	4	1	7		11	1
	Clerical & Financial Serv.	96	62	14	9	110	71
	Trade & Craft Service	99	54	3		102	54
	Manual & Custodial Serv.	266	137			266	137
	Total	482	260	44	11	526	271
JIMMAA TEACHERS COLLEGE	Professional Service	1		7	2	8	2
	Sub-Professional Service	6				6	
	Administrative Service	2		3	1	5	1
	Clerical & Financial Serv.	20	15	1	1	21	16
	Trade & Craft Service	36	21			36	21
	Manual & Custodial Serv.	37	14			37	14
	Total	102	50	11	4	113	54
WONDO GENET COLLEGE OF FORESTRY *	Professional Service			2	1	2	1
	Sub-Professional Service	6		2		8	
	Administrative Service	3	1	1		4	1
	Clerical & Financial Serv.	12	6	2	1	14	7
	Trade & Craft Service	26	4			26	4
	Manual & Custodial Serv.	53	7			53	7
	Total	100	18	7	2	107	20
MEKALLE UNIVERSITY	Professional Service			2		2	
	Sub-Professional Service	3		9		12	
	Administrative Service	4	1	6		10	1
	Clerical & Financial Serv.	46	33	34	18	80	51
	Trade & Craft Service	126	87			126	87
	Manual & Custodial Serv.	174	106			174	106
	Total	353	227	51	18	404	245
TIGRAY ARTS COLLEGE	Professional Service						
	Sub-Professional Service	1	1	1	1	2	2
	Administrative Service						
	Clerical & Financial Serv.	12	10	2	2	14	12
	Trade & Craft Service						
	Manual & Custodial Serv.	27	18			27	18
	Total	40	29	3	3	43	32
NAZARETH TECHNICAL COLLEGE	Professional Service			3	1	3	1
	Sub-Professional Service	4		10	1	14	1
	Administrative Service			7		7	
	Clerical & Financial Serv.	32	21	23	15	55	36
	Trade & Craft Service	56	30			56	30
	Manual & Custodial Serv.	135	41			135	41
	Total	227	92	43	17	270	109
DILLA COLLEGE OF TEACHER EDUCATION AND HEALTH SCIENC	Professional Service			1		1	
	Sub-Professional Service	1		3		4	
	Administrative Service	6	1	3		9	1
	Clerical & Financial Serv.	33	24	3	2	36	26
	Trade & Craft Service	65	43			65	43
	Manual & Custodial Serv.	121	55			121	55
	Total	226	123	10	2	236	125

University/Institute/College/Faculty Department	Level of Education Type of Occupation	12 th Grade and below		Certificate and Above		Total	
		BS	F	BS	F	BS	F
	GONDAR COLLEGE OF TEACHER.EDUCATION	Professional Service			2		2
	Sub-Professional Service			3	1	3	1
	Administrative Service			4		4	
	Clerical & Financial Serv.	31	17	3	1	34	18
	Trade & Craft Service	38	29	1		39	29
	Manual & Custodial Serv.	45	21			45	21
	Total	114	67	13	2	127	69
ABBIYI ADDI COLLEGE OF TEACHER.EDUCATION	Professional Service						
	Sub-Professional Service	3	2	3	1	6	3
	Administrative Service	2		2		4	
	Clerical & Financial Serv.	16	10			16	10
	Trade & Craft Service	20	16			20	16
	Manual & Custodial Serv.	37	20			37	20
	Total	78	48	5	1	83	49
AWASSA COLLEGE OF TEACHER.EDUCATION*	Professional Service						
	Sub-Professional Service			5	2	5	2
	Administrative Service			10		10	
	Clerical & Financial Serv.	28	18	2	2	30	20
	Trade & Craft Service	20	10			20	10
	Manual & Custodial Serv.	30	15			30	15
	Total	78	43	17	4	95	47
MAICHEW TECHNIC COLLEGE	Professional Service			1		1	
	Sub-Professional Service	6	4	3	1	9	5
	Administrative Service	2		1		3	
	Clerical & Financial Serv.	14	10	3		17	10
	Trade & Craft Service	15	5			15	5
	Manual & Custodial Serv.	33	13			33	13
	Total	70	32	8	1	78	33
ETHIOPIAN MASS MEDIA TRAINING INSTITUTE	Professional Service			3		3	
	Sub-Professional Service			5	2	5	2
	Administrative Service	1		5	3	6	3
	Clerical & Financial Serv.	5	5	11	10	16	15
	Trade & Craft Service	5		1		6	
	Manual & Custodial Serv.	30	16	1	1	31	17
	Total	41	21	26	16	67	37
Total	Professional Service	6	3	98	21	104	24
	Sub-Professional Service	278	94	389	126	667	220
	Administrative Service	61	12	146	32	207	44
	Clerical & Financial Serv.	961	618	422	303	1383	921
	Trade & Craft Service	1429	710	37	9	1466	719
	Manual & Custodial Serv.	2805	1382	20	17	2825	1399
Grand Total		5540	2819	1112	508	6652	3327

* 1993 E.C Data

Administrative and General Service Staff
by Institution, Sex and Level of Education Upto Grade 12
2000/01 (1993 E.C.) Acadmic Year First Semester

University/Institute/College/Faculty Department	Illitrat		Litrata		Grade 1- 6		Grade 7 - 8		Grade 9 - 12		Total	
	BS	F	BS	F	BS	F	BS	F	BS	F	BS	F
ADDIS ABABA UNIVERSITY*			250	150	278	165	133	84	524	314	1185	713
AWASSA COLLEGE OF AGRICULTURE*	24	17	14	6	75	31	40	11	85	29	238	94
BAHIRDAR UNIVERSITY	14	8	27	10	89	49	39	20	124	71	293	158
GONDER COLLEGE OF MEDICAL SCIENCE*			34	14	180	103	48	26	182	104	444	247
ALEMAYA UNIVERSITY*			173	59	166	38	40	16	122	38	501	151
AMBO COLLEGE OF AGRICULTURE			12	2	68	20	25	6	67	25	172	53
JIMMA TEACHERS COLLEGE					34	10	18	10	50	30	102	50
JIMMA AGRICULTURE COLLEGE					92	23	35	14	54	21	181	58
JIMMA INSTITUTE OF HEALTH SCIENCE					140	68	113	62	229	130	482	260
ADDIS ABABA COLLEGE OF COMMERCE			7	3	33	13	8	3	46	30	94	49
KOTEBE COLLEGE OF TEACHER EDU.	2	1	8	4	38	16	34	23	107	74	189	118
ARBA MINCH WATER TECHNOLOGY INSTITUTE			24	9	97	52	35	12	54	18	210	91
ETHIOPIAN CIVIL SERVICE COLLEGE	2	1	3	1	28	21	17	8	72	46	122	77
WONDO GENET COLLEGE OF FORESTRY*	12		23	4	26	5	17	1	22	8	100	18
NAZARETH TECHNICAL COLLEGE			16	8	44	17	55	20	112	47	227	92
ETHIOPIAN MASS MEDIA TRAINING INSTITUTE					16	7	3	1	22	13	41	21
ABBIIYI ADDI COLLEGE OF TEACHER EDUCATION					28	14	18	13	32	21	78	48
AWASSA COLLEGE OF TEACHER EDUCATION*			19	10	12	3	5	2	42	28	78	43
GONDAR COLLEGE OF TEACHER EDUCATION	5	2	6	4	18	12	23	18	62	31	114	67
MAICHEW TECHNICAL COLLEGE			2		5	1	26	7	37	24	70	32
MEKALLE UNIVERSITY	8	5	1		97	68	122	79	125	75	353	227
TIGRAY ARTS COLLEGE			5	4	1	1	10	9	24	15	40	29
DILLA COLLEGE OF TEACHER EDU. & HEA. Sc.					66	41	42	20	118	62	226	123
Total	67	34	624	288	1631	778	906	465	2312	1254	5540	2819

* 1993 E.C Data

ETHIOPIAN SCHOLARSHIP STUDENTS

Definition of concepts

Ethiopian Students Sent Abroad Through government Scholarship

These are Ethiopian students sent abroad for higher students after fulfilling the criteria set up by the Ministry of Education. This section does not include students sent for higher education to foreign countries through special agreements between the scholarship granting countries of agencies and other government organizations of individuals.

Graduate Returnees from Studies Abroad

These are Ethiopian students who have satisfactorily completed their designated programmes abroad and presented their awarded diploma to be registered by scholarship office of the Ministry of Education. These students might have obtained their scholarship through government or private means.

Country of study

This is the country where the students have been sent to study through the Ministry of Education.

Academic Qualification

This is the level of education the student has achieved or is expected to achieve upon completion of his studies. It is usually designated by the type of diploma or degree earned at the end of the study period.

**Ethiopian Students Sent Abroad Through Government Scholarships for
Short Term/Advanced Training Programmes During 2001/02 (1994 E.C.)**

Country \ Sex		Agriculture		Technology		Natural Sc.		Social Sc.		Medical Sc.		Total	
		BS	F	BS	F	BS	F	BS	F	BS	F	BS	F
GERMANY		4	1	3		1						8	1
JAPAN		8		14		2		12	5	2		38	5
INDIA		1		9	1	3		9	3			22	4
SWEDEN			5			4		3	1			7	6
IDONESIA		3										3	
POLAND								1				1	
NETHERLAND		1						16	2			17	2
SUDAN				2								2	
KOREA		3		3		2		6				14	
EGYPT				3		1				1		5	
ISRAEL		2	1	1						2		5	1
MALAYSIA		1						1	1			2	1
Total		23	7	35	1	13		48	12	5		124	20

**Ethiopian Students Sent Abroad Through Government Scholarships for
Undergraduate Degree During 2001/02 (1994 E.C.)**

Country \ Sex		Agriculture		Technology		Natural Sc.		Social Sc.		Medical Sc.		Total	
		BS	F	BS	F	BS	F	BS	F	BS	F	BS	F
CZECH								1				1	
SUDAN				1		1						2	
INDIA				1		1		6				8	
Total				2		2		7				11	

**Ethiopian Students Sent Abroad Through Government Scholarships for
Postgraduate Degree During 2001/02 (1994 E.C.)**

Country \ Sex		Agriculture		Technology		Natural Sc.		Social Sc.		Medical Sc.		Total	
		BS	F	BS	F	BS	F	BS	F	BS	F	BS	F
NETHERLANDS		6		14		12		10	5			42	5
JAPAN				1				1				2	
MEXICO		2										2	
ITALY				2								2	
CZECH						1						1	
INDIA								3				3	
Total		8		17		13		14	5			52	5

**Ethiopian Graduate Returnees From Abroad With
Diploma or Certificate During 2001/02 (1994 E.C.)**

Country \ Sex		Agriculture		Technology		Natural Sc.		Social Sc.		Medical Sc.		Total	
		BS	F	BS	F	BS	F	BS	F	BS	F	BS	F
GERMANY		2		9		4	1	7	1	1		23	2
NETHERLAND		2		1		8	1	4	1			15	2
INDIA				1		4	1			1		6	1
NORWAY										1		1	
JAPAN										1	1	1	1
U.S.A.				1		1				1		3	
KENYA								11		1	1	12	1
ROMANIA										1		1	
ENGLAND				1	1	1		1				3	1
BELGIUM						2						2	
EGYPT								1				1	
GHANA				2				1				2	
IRELAND								1				1	
SOUTH AFRICA				1				2		2		5	
Saudi Arabia								3				3	
FRANCE										1	1	1	1
ALGERIA				1								1	
Total		4		17	1	20	3	30	2	10	3	81	9

**Ethiopian Graduate Returnees From Abroad With
B.A/B.Sc. or Equivalent During 2001/02 (1994 E.C.)**

Country \ Sex		Agriculture		Technology		Natural Sc.		Social Sc.		Medical Sc.		Total	
		BS	F	BS	F	BS	F	BS	F	BS	F	BS	F
ENGLAND				1				1				2	
INDIA				3	1	6	2	17	5			26	8
ITALY				1				1				2	
IRELAND						1		1	1			2	1
KENYA								5				5	
NETHERLAND		2	1					1				3	1
LIBYA								2				2	
U.S.A.				1	1	1		3	1			5	2
PHILIPPINES								1	1			1	1
SOUTH AFRICA								2				2	
SUDAN						1						1	
CHINA						1						1	
CUBA								1	1			1	1
PAKISTAN		1		5		1		2	1	1		10	1
BANGLADESH				1								1	
Saudi Arabia								1				1	
Total		3	1	12	2	11	2	38	10	1		65	15

Ethiopian Graduate Returns From Abroad With
M.A/M.Sc. or Equivalent During 2001/02 (1994 E.C.)

Country	Agriculture		Technology		Natural Sc.		Social Sc.		Medical Sc.		Total	
	BS	F	BS	F	BS	F	BS	F	BS	F	BS	F
ENGLAND	1				3		16	1	4	1	24	2
GERMANY	4	2	3	1			4	2	2		13	5
NETHERLAND	13	1	14		5		14	4			46	5
INDIA	16		9		6		16	6	2		49	6
UGANDA							1	1			1	1
SWEDEN	2				1				2		5	
RUSSIA	1		1				1				3	
JAPAN			1				1		1	1	3	1
IRELAND	2	1	3				3	1	1	1	9	3
UKRAIN	1		1								2	
SOUTH AFRICA	5				2		5	1	2	1	14	2
ITALY			1				1		2	2	4	2
CHINA			5				3		1		9	
FRANCE							4				4	
PHILIPINES	1	1					2	1			3	2
NORWAY			1		2		6	2			9	2
GHANA					1		3	1			4	1
BULGARIA	1										1	
BELGIUM					3		2	1			5	1
U.S.A.	1		1				10	3	1	1	13	4
CANADA							1				1	
MAISIA							1				1	
AUSTRIA							1		2		3	
POLAND			1								1	
PAKISTAN							1				1	
KENYA							4	1			4	1
Total	48	5	41	1	23		100	25	20	7	232	38

Ethiopian Graduate Returns From Abroad With
Ph. D. or Equivalent During 2001/02 (1994 E.C.)

Country	Agriculture		Technology		Natural Sc.		Social Sc.		Medical Sc.		Total	
	BS	F	BS	F	BS	F	BS	F	BS	F	BS	F
ENGLAND	2	2	2				1				5	2
GERMANY	3	1	3		3		1		3		13	1
INDIA	2				4		3		1		10	
SWEDEN	2				2				1		5	
U.S.A									1	1	1	1
AUSTRIA	1				2		1		2		6	
SOUTH AFRICA	3				1		1		3		8	
NETHERLAND	5		1		1		1	1	1		9	1
RUSSIA	1						1				2	
ROMANIA									2	1	2	1
KENYA							4		1		5	
CUBA									2		2	
AUSTRALIA							1		1		2	
NORWAY			1		1	1	5	1			7	2
BELGIUM							1		1		2	
TANZANIA	1										1	
SPAIN			1								1	
DENMARK	1										1	
THAILAND	1								1		2	
EGYPT	1										1	
ZIMBABWE							1	1			1	1
MALISIA	1										1	
Total	24	3	8		14	1	21	3	20	2	87	9

Recurrent Budget Allocated to Institutions of Higher Education
2001/02 (1994 E.C.)

INSTITUTION	Approved Budget 1993 E.C	Approved Budget 1994 E.C.		
		Total	Salary *	% Salary
ADDIS ABABA UNIVERSITY	111,504,700.00	135,714,200.00	42,175,900.00	31.08
BAHIR DAR UNIVERSITY	16,544,600.00	24,669,100.00	7,773,100.00	31.51
JIMMA UNIVERSITY	26,160,300.00	33,951,500.00	11,066,300.00	32.59
DEBUB UNIVERSITY	24,462,500.00	29,196,400.00	10,309,600.00	35.31
MEKELE UNIVERSITY	13,599,000.00	27,110,600.00	2,370,800.00	8.74
ALEMAYA UNIVERSITY	17,128,700.00	22,169,300.00	9,147,200.00	41.26
AMBO COLLEGE OF AGRICULTURE	4,406,200.00	7,433,200.00	2,557,600.00	34.41
ADDIS ABABA COLLEGE OF COMMERCE	8,061,000.00	10,006,800.00	4,092,900.00	40.90
ARBA MINCH WATER TECHNOLOGY INSTITUTE	9,437,500.00	13,064,000.00	5,065,300.00	38.77
NAZARETH COLLEGE OF TECHNICAL TEACHER EDUCATION	6,217,900.00	7,248,000.00	2,666,900.00	36.79
GONDER COLLEGE OF MEDICAL SCIENCE	17,345,300.00	17,917,200.00	6,661,600.00	37.18
GRAND TOTAL	254,867,700.00	328,480,300.00	103,887,200.00	31.63

* Includes Allowance

CONTINUING EDUCATION

Definition of concepts

Extension (Evening) Programmes

These are programmes offered by institutions of higher education in extension (evening) classes.

Kiremt Teacher Training Programmes

These are programmes offered to employees recommended by the Ethiopian Ministry of Education, various Institutions of Higher Education and similar organizations engaged in teaching activities. This programmes is offered during the Ethiopian "Kiremt" (Summer) season, normally from July to August.

Data on New Admission, Readmission and Enrollment in Extension (Evening)
Diploma and Undergraduate Degree Programmes
2001/02 (1994 E. C.) Academic Year - First Semester

University/Institute/College/Faculty Department	Diploma						Undergraduate Degree					
	New Admission		Readmission		Enrollment		New Admission		Readmission		Enrollment	
	BS	F	BS	F	BS	F	BS	F	BS	F	BS	F
ADDIS ABABA UNIVERSITY	971	205	59	11	3320	874	1610	485	74	17	4964	1444
Faculty of Business & Economics			2		134	32	350	71	8	1	1872	310
Accounting			2		60	13	111	21			623	106
Economics							97	13	8	1	576	87
Management							142	37			673	117
Supervisory Management					74	19						
College of Social Sciences							426	127	17	4	976	365
Geography							90	20	2		237	81
History							73	19	4		153	54
Political Sci. & International Relations							124	34	5		221	72
Sociology & Social Administration							139	54	6	4	365	158
Faculty of Education			2	2	88	33	263	136	10	4	719	355
Business Education			1	1	42	19	185	120	8	4	489	304
Educational Administration			1	1	46	14	78	16	2		230	51
Faculty of Law	106	15	6		431	68						
Law	106	15	6		431	68						
Faculty of Science	358	125	12	4	768	272						
Biology	67	29	3	1	137	63						
Chemistry	85	27	1		175	62						
Computer Science	62	15	3	1	130	34						
Mathematics	79	26	2		156	50						
Statistics	65	28	3	2	170	63						
Faculty of Technology	430	35	31	3	1282	113	248	19	28	4	591	59
Building Engineering	85	4	3		317	26						
Civil Engineering	113	10	8	3	404	40			9	4		
Electrical Engineering	91	7	10		242	25			1			
Mechanical Engineering	78	3	10		256	11						
Chemical Engineering	63	11			63	11						
Engineering(Degree)							248	19	18		591	59
Institute of Language Studies			2	1	378	253	189	91	5	2	367	184
Ethiopian Lang. & Literature					187	121	84	41	1		155	85
Foreign Lang. & Liter.			2	1	191	132	105	50	4	2	212	99
Information Studies			1		68	43	134	41	6	2	439	171
Library Science			1		68	43	134	41	6	2	439	171
School of Pharmacy	77	30	3	1	171	60						
Pharmacy	77	30	3	1	171	60						
DEBUB UNIVERSITY	394	138	47	10	552	163	467	62	41	7	863	96
Dilla Teacher Education and Health Science College							122	20	8	1	357	38
Chemistry												
Biology									1		51	6
English											59	6
Geography							122	20	7	1	247	26
Awassa College of Agriculture	377	138	39	10	504	160	301	40	29	6	419	54
Basic Science /BSD/	281	102	8	3	289	105	71	15	8		101	17
General Agriculture /GeAg/			7	1	7	1						
HOST			1		1							
Plant Prod. & DLF /PPDF/							141	21	21	6	229	33
BSD/Wolayta	96	36			96	36	37				37	
AgEM					1		16				16	
APRM							36	4			36	4
PST			23	6	110	18						
Wondo Genet Forestry	17		8		48	3	44	2	4		87	4
Forestry	17		8		48	3	44	2	4		87	4
ALEMAYA UNIVERSITY	736	244	109	5	1814	469						
Accounting	472	146	65	4	1231	303						
Management	264	98	44	1	583	166						

University/Institute/College/Faculty Department	Diploma						Undergraduate Degree					
	New Admission		Readmission		Enrollment		New Admission		Readmission		Enrollment	
	BS	F	BS	F	BS	F	BS	F	BS	F	BS	F
BAHIR DAR UNIVERSITY	3529	901	20	2	5942	1417	2	6	1	156	19	
Bahir Dar Teachers College	2445	769	20	2	4858	1285	2	6	1	156	19	
<i>Pedagogical Science</i>									5	1	107	11
<i>Amharic</i>	231	136			465	260						
<i>Biology</i>	167	68			249	76						
<i>English</i>	138	30	4		389	70	2		1		49	8
<i>Chemistry</i>												
<i>Geography</i>	207	42	5		564	79						
<i>Mathematics</i>	165	21	1		285	30						
<i>History</i>	221	24	4	1	475	55						
<i>Law</i>	163	23	4		492	64						
<i>Accounting</i>	224	53	1		715	103						
<i>Physical Education</i>	171	7			255	15						
<i>Bank & Finance</i>	170	46			170	46						
<i>Business Management</i>	155	20			155	20						
<i>Marketing</i>	152	24			152	24						
<i>Secretarial Science</i>	281	275	1	1	492	443						
Bahir Dar Polytechnic Institute	1084	132			1084	132						
<i>Freshman Programme</i>	513	70			513	70						
<i>Chemical Engineering</i>	49	7			49	7						
<i>Civil Engineering</i>	200	19			200	19						
<i>Mechanical Engineering</i>	140	11			140	11						
<i>Electrical Engineering</i>	182	25			182	25						
<i>Electrical Technology</i>												
ARBA MINCH INSTITUTE OF TECHNOLOGY	128	7	9	1	258	17						
<i>Building Engineering</i>	21		6	1	81	2						
<i>Civil Engineering</i>	107	7	3		177	15						
AMBO COLLEGE OF AGRICULTURE	222	46	37	12	570	111						
<i>General Agriculture</i>	222	46	37	12	570	111						
JIMMA UNIVERSITY	653	172	52	23	1418	377	211	24			211	24
Jimma Institute of Health Science	532	142	52	23	1228	334	128	14			128	14
Faculty of Business	367	120	35	19	865	286	128	14			128	14
<i>Accounting</i>	252	102	22	13	626	224	66	11			66	11
<i>Management</i>	115	18	13	6	239	62	62	3			62	3
Faculty of Technology	113	16	15	2	238	30						
<i>Civil Engineering</i>	113	16	15	2	238	30						
Faculty of Medicine	52	6	2	2	125	18						
<i>Pharmacy School</i>	52	6	2	2	125	18						
JIMMA COLLEGE OF AGRICULTURE	121	30			190	43	83	10			83	10
<i>General Agriculture</i>	121	30			190	43						
<i>Horticulture</i>							83	10			83	10
ADDIS ABABA COLLEGE OF COMMERCE	1510	459	134	39	3,609	1047						
<i>Accounting</i>	440	56	45	5	1,134	123						
<i>Banking & Finance</i>	213	19	22	7	586	65						
<i>Marketing Management</i>	246	32	29	6	490	66						
<i>Personal Management</i>	108	11	9	3	239	21						
<i>Purchasing & Supply Management</i>	114	3	13	3	350	16						
<i>Secretarial Sc. & Office Management (BL)</i>	323	321	13	13	696	693						
<i>Secretarial Sc. & Office Management (TL)</i>	11	11	3	2	59	57						
<i>BIS</i>	55	6			55	6						
KOTEBE COLLEGE OF TEACHER EDUCATION	1317	361	52	18	2478	574	44	9	1	366	50	
<i>English</i>	177	55	7	2	341	85			2	1	100	27
<i>Mathematics</i>	196	45	10	2	324	64			1		50	9
<i>Biology</i>	150	50	4	2	268	71						
<i>Chemistry</i>	112	25	4	1	205	35						
<i>History</i>	97	16	2	2	231	40						
<i>Geography</i>	203	33	4	3	389	57			1		24	2
<i>Business Education</i>												
<i>Ethiopian Languages</i>	216	121	9	6	360	193					26	6
<i>Health & Physical Education</i>	101	10	6		202	16	44		5		166	6
<i>Physics</i>	65	6	6		158	13						
AWASSA COLLEGE OF TEACHER EDUCATION	1299	264	50	16	2615	562						
<i>English</i>	215	63	6	1	480	129						
<i>Amharic</i>	212	115	12	8	470	276						
<i>Mathematics</i>	123	16	8	1	208	23						
<i>Physics</i>	92	4			118	4						
<i>Biology</i>	183	40	7	4	425	80						
<i>Geography</i>	206	17	5		435	27						
<i>History</i>	139	2	4		246	9						
<i>Chemistry</i>	129	7	8	2	233	14						

University/Institute/College/Faculty Department	Diploma						Undergraduate Degree					
	New Admission		Readmission		Enrollment		New Admission		Readmission		Enrollment	
	BS	F	BS	F	BS	F	BS	F	BS	F	BS	F
GONDAR COLLEGE OF TEACHER EDUCATION	688	250	19	9	1329	415						
<i>Amharic</i>	130	76	5	4	227	133						
<i>English</i>	128	73	1	1	206	89						
<i>Mathematics</i>	52	6	3	1	135	14						
<i>Biology</i>	66	26	3	1	144	54						
<i>Chemistry</i>	56	13	4	1	150	29						
<i>Physics</i>	29	4			48	9						
<i>Geography</i>	160	44	1	1	273	73						
<i>History</i>	67	8	2		146	14						
JIMMA COLLEGE OF TEACHER EDUCATION	477	93			1006	173						
<i>A/Oromo</i>	128	48			314	87						
<i>English</i>	59	2			135	15						
<i>Amharic</i>	51	32			69	45						
<i>Geography</i>	63	3			147	6						
<i>History</i>	52	3			88	7						
<i>Biology</i>	48	4			105	10						
<i>Chemistry</i>	31				56	1						
<i>Mathematics</i>	45	1			92	2						
MAKELE UNIVERSITY	895	267	42	16	2,223	674	291	62	205	44	1,112	223
Makele University College	250	36	16	3	863	149					19	
Faculty of Dryland Agriculture			5		23	6						
<i>Soil and Water Conservation</i>			5		23	6						
Faculty of Law	72	18			311	71						
<i>Law</i>	72	18			311	71						
Faculty of Science & Technology	140	7	8	2	364	20					19	
<i>Civil Engineering</i>	140	7	8	2	336	20						
<i>Industrial Engineering</i>					28						19	
Faculty Education	38	11	3	1	165	52						
<i>Biology</i>			2	1	61	23						
<i>English</i>	38	11	1		104	29						
Makale Business College	645	231	26	13	1,360	525	291	62	205	44	1,093	223
<i>Accounting</i>	188	50	10	4	451	139	96	27	56	22	353	103
<i>Economics</i>							108	22	87	8	408	50
<i>Management</i>	171	23	7	2	377	65	87	13	62	14	332	70
<i>Banking and Finance</i>	146	47	4	2	248	84						
<i>Secretarial Science and Office Management</i>	112	106	5	5	233	227						
<i>Computer Science</i>	28	5			51	10						
ETHIOPIA CIVIL SERVICE COLLEGE	181	22	137	21	485	77						
<i>Law</i>	81	17	92	13	282	44						
<i>Accounting</i>	100	5	45	8	203	33						
NAZARETH TECHNICAL COLLEGE	437	96	34	9	1048	234					43	
<i>Automotive Technology</i>	44	2	4		81	3					10	
<i>Construction Technology</i>	62	3	2		152	8					8	
<i>Drafting and Surveying Technology</i>	19	7	4	1	60	24						
<i>Electricity/Electronics Technology</i>	50	5	3	1	124	9					18	
<i>Manufacturing Technology</i>	15		4		39						7	
<i>Surveying Technology</i>	48	3	5		126	6						
<i>Accounting</i>	139	58	8	5	337	146						
<i>Marketing Management</i>	60	18	4	2	129	38						
MAICHEW TECHNICAL COLLEGE	47	9	2		148	22						
<i>Automotive Technology</i>					12							
<i>Construction Technology</i>	23	5	1		64	10						
<i>Electrical Technology</i>	24	4	1		63	11						
<i>Manufacturing Technology</i>					9	1						
ABIY ADDI COLLEGE OF TEACHER EDUCATION	893				893							
<i>Tigreigna</i>	199				199							
<i>Amharic</i>	163				163							
<i>Mathematics</i>	106				106							
<i>English</i>	180				180							
<i>Chemistry</i>	98				98							
<i>Biology</i>	85				85							
<i>Geography</i>	62				62							
ETHIOPIA MASS MEDIA	150	48			150	48						
<i>Print</i>	150	48			150	48						
GONDER COLLEGE OF MEDICAL SCIENCE	522	198			522	198						
<i>Laboratory Technology</i>	67	31			67	31						
<i>Pharmacy</i>	60	16			60	16						
<i>Accounting</i>	158	57			158	57						
<i>Marketing Management</i>	80	33			80	33						
<i>Business Management</i>	157	61			157	61						
GRAND TOTAL	14,527	3,582	803	192	30,380	7,452	2,625	633	335	70	7,715	1,856

Graduates from Extension (Evening) Diploma, Undergraduate Degree
by Institution, Department and Sex
2001/02 (1994 E.C.) Academic Year

University/Institute/College/Faculty Department	Diploma		Undergraduate Degree		Total	
	BS	F	BS	F	BS	F
ADDIS ABABA UNIVERSITY	489	120	328	71	817	191
Faculty of Business & Economics	42	12	145	14	187	26
<i>Accounting</i>	18	3	64	4	82	7
<i>Economics</i>			39	2	39	2
<i>Management</i>			42	8	42	8
<i>Supervisory Mgt.</i>	24	9			24	9
Faculty of Social Science			44	8	44	8
<i>Geography</i>			12	2	12	2
<i>History</i>			5	2	5	2
<i>PSIR</i>			12	2	12	2
<i>SOSA</i>			15	2	15	2
Faculty of Education	39	14	60	28	99	42
<i>Business Education</i>	19	7	32	21	51	28
<i>Educational Administration</i>	20	7	28	7	48	14
Faculty of Law	99	15			99	15
Faculty of Science	88	25			88	25
<i>Biology</i>	17	10			17	10
<i>Chemistry</i>	15	2			15	2
<i>Computer Science</i>	21	6			21	6
<i>Mathematics</i>	12				12	
<i>Statistics</i>	23	7			23	7
Information Studies	25	18	28	13	53	31
<i>Library and Information Science</i>	25	18	28	13	53	31
Institute of Language Studies	41	23	9	4	50	27
<i>Ethiopian Language and Literature</i>	17	11	2	2	19	13
<i>Foreign Language and Literature</i>	24	12	7	2	31	14
Faculty of Technology	155	13	42	4	197	17
<i>Civil Engineering</i>	46	1	38	4	84	5
<i>Building Engineering</i>	50	5			50	5
<i>Electrical Engineering</i>	29	3	4		33	3
<i>Mechanical Engineering</i>	30	4			30	4
DEBUB UNIVERSITY	83	9			83	9
Awassa College of Agriculture	59	7			59	7
<i>Agricultural Engineering and Mechanisation</i>	1				1	
<i>Home Science and Technology</i>	1				1	
<i>General Agriculture</i>	4				4	
<i>PST</i>	53	7			53	7
Wondo Genet College of Forestry	24	2			24	2
<i>Forestry</i>	24	2			24	2
BAHIR UNIVERSITY	1026	201	50	3	1076	204
Bahir Dar Polytechnic Institute	48	6			48	6
<i>Agromechanics</i>						
<i>Electrical Engineering</i>	10	2			10	2
<i>Civil Engineering</i>	23	3			23	3
<i>Mechanical Engineering</i>	15	1			15	1
Bahir Dar Teachers College	978	195	50	3	1028	198
<i>Amaharic</i>	99	53			99	53
<i>English</i>	111	25	22	3	133	28
<i>Geography</i>	133	17	28		161	17
<i>Biology</i>	75	9			75	9
<i>Mathematics</i>	54	5			54	5
<i>History</i>	137	18			137	18
<i>Accounting</i>	194	20			194	20
<i>Secreterial Science & Office Management</i>	57	37			57	37
<i>Law</i>	118	11			118	11
AMBO COLLEGE OF AGRICULTURE	164	28			164	28
<i>General Agriculture</i>	164	28			164	28
ALEMAYA UNIVERSITY	201	42			201	42
<i>Accounting</i>	139	31			139	31
<i>Management</i>	62	11			62	11

University/Institute/College/Faculty Department	Diploma		Undergraduate Degree		Total	
	BS	F	BS	F	BS	F
JIMMA UNIVERSITY	219	53			219	53
Jimma Institute of Health Science	207	52			207	52
<i>Accounting</i>	150	42			150	42
<i>Management</i>	34	9			34	9
<i>Civil Engineering</i>	23	1			23	1
Jimma College of Agriculture	12	1			12	1
<i>General Agriculture</i>	12	1			12	1
ADDIS ABABA COLLEGE OF COMMERCE	552	158			552	158
<i>Accounting</i>	182	13			182	13
<i>Banking & Finance</i>	107	18			107	18
<i>Marketing Management</i>	47	4			47	4
<i>Human Resource Mgt.</i>	30	1			30	1
<i>Purchasing and Supply Management</i>	63	1			63	1
<i>Secretarial Sc. & Office Mgt. (Bi-lingual)</i>	105	105			105	105
<i>Secretarial Sc. & Office Mgt. (Tri-lingual)</i>	18	16			18	16
MAKALLE UNIVERSITY	162	58			162	58
Makale University College	73	15			73	15
<i>Law</i>	32	7			32	7
<i>Soil and Water Conservation</i>	22	5			22	5
<i>Civil Engineering</i>	19	3			19	3
Makele Business College	89	43			89	43
<i>Accounting</i>	47	17			47	17
<i>Economics</i>	3				3	
<i>Management</i>	19	6			19	6
<i>Secretarial Science and Office Management</i>	20	20			20	20
NAZARETH TECHNICAL COLLEGE	231	61	42		273	61
<i>Automotive Technology</i>	7		11		18	
<i>Construction Technology</i>	22	1	8		30	1
<i>Drafting Technology</i>	9	2			9	2
<i>Electricity/Electronics Technology</i>	20	1	19		39	1
<i>Surveying Technology</i>	21				21	
<i>Manufacturing Technology</i>	9		4		13	
<i>Accounting</i>	122	54			122	54
<i>Marketing Management</i>	21	3			21	3
GONDAR COLLEGE OF TEACHER EDUCATION	196	39			196	39
<i>Amharic</i>	30	20			30	20
<i>English</i>	28	5			28	5
<i>Mathematics</i>	31	2			31	2
<i>Biology</i>	18	4			18	4
<i>Chemistry</i>	28				28	
<i>Geography</i>	39	8			39	8
<i>History</i>	22				22	
KOTEBE COLLEGE OF TEACHER EDUCATION	478	88	190	37	668	125
<i>Biology</i>	48	8			48	8
<i>Chemistry</i>	38	4			38	4
<i>Physics</i>	30	4			30	4
<i>Ethiopian Language and Literature</i>	56	30	25	6	81	36
<i>English</i>	69	7	97	22	166	29
<i>Mathematics</i>	57	9	40	7	97	16
<i>History</i>	68	14			68	14
<i>Geography</i>	74	10	27	2	101	12
<i>Health and Physical Education</i>	38	2	1		39	2
JIMMA COLLEGE OF TEACHER EDUCATION	160	24			160	24
<i>Oromigna</i>	65	8			65	8
<i>English</i>	18	2			18	2
<i>Geography</i>	32	2			32	2
<i>Biology</i>	19	1			19	1
<i>Mathematics</i>	12	1			12	1
<i>Amharic</i>	14	10			14	10
AWASSA COLLEGE OF TEACHER EDUCATION	354	80			354	80
<i>English</i>	69	16			69	16
<i>Amharic</i>	70	43			70	43
<i>Mathematics</i>	24	2			24	2
<i>Biology</i>	64	9			64	9
<i>Geography</i>	58	4			58	4
<i>History</i>	39	4			39	4
<i>Chemistry</i>	30	2			30	2
Arbaminich Water Technology Insititute	53	3			53	3
<i>Building Engineering</i>	27				27	
<i>Civil Engineering</i>	26	3			26	3
ETHIOPIAN CIVIL SERVICE COLLEGE	98	18			98	18
<i>Law</i>	69	11			69	11
<i>Accounting</i>	29	7			29	7
Grand Total	4466	982	610	111	5076	1093

Data on New Admission, Readmission and Enrollment in Kiremt Teacher Education
Diploma and Undergraduate Degree Programmes
by Institution, Department, Year of Study and Sex
2001/2002 (1994 E. C.) Academic Year

University/Institute/College/Faculty Department	Diploma						Undergraduate Degree					
	New Admission		Readmission		Enrollment		New Admission		Readmission		Enrollment	
	BS	F	BS	F	BS	F	BS	F	BS	F	BS	F
ADDIS ABABA UNIVERSITY			1		1		392	71	20	4	445	79
College of Social Sciences							80	10	2		82	10
<i>Geography</i>							40	7	2		42	7
<i>History</i>							40	3			40	3
Faculty of Education			1		1							
<i>Educational Administration</i>			1		1							
Faculty of Science							192	22	12	2	204	24
<i>Biology</i>							40	6	3		43	6
<i>Chemistry</i>							40	9	1	1	41	10
<i>Mathematics</i>							80	6	2		82	6
<i>Physics</i>							32	1	6	1	38	2
Institute of Language Studies							120	39	6	2	159	45
<i>Ethiopian Language and Literature</i>							40	17	3	1	57	20
<i>Foreign Language and Literature</i>							80	22	3	1	102	25
DEBUB UNIVERSITY	44	21	19	18	255	89	433	34	27	1	1,278	80
Dilla College of Teacher Education and Health Sc.							412	31	27	1	1199	75
<i>Amharic</i>							78	10	5	1	191	26
<i>Biology</i>							41	5	3		147	11
<i>Chemistry</i>							40	1	4		145	6
<i>English</i>							40	4	1		149	10
<i>Geography</i>							77	5	1		191	13
<i>History</i>							28				110	
<i>Mathematics</i>							77	5	10		172	8
<i>Physics</i>							31	1	3		94	1
Awassa College of Agriculture	44	21	19	18	255	89	21	3			79	5
<i>APRM</i>							21	3			21	3
<i>PPDF</i>											58	2
<i>AgEM</i>	23				23							
<i>Host</i>	21	21	19	18	96	85						
<i>GeAg</i>					93	1						
<i>AST</i>					43	3						
ALEMAYA UNIVERSITY	373	28			903	93	307	18	2		940	45
<i>Biology</i>	64	6			147	20	56	6			181	13
<i>Chemistry</i>	55	2			122	12	42	1			158	10
<i>Geography</i>	78	5			138	14	50	1	1		128	3
<i>History</i>							39	1			117	5
<i>Mathematics</i>	83	6			213	16	43		1		191	5
<i>English</i>	93	9			217	22	60	7			60	7
<i>Physics</i>					66	9	17	2			105	2
MAKELE UNIVERSITY							216	15			431	40
Makele University College							216	15			431	40
Faculty of Dryland Agriculture							59	3			206	26
<i>Animal and Range Science</i>							16	1			46	5
<i>Dryland Crop Science</i>							25	2			105	18
<i>Soil and Water Conservation</i>							18				55	3
Faculty of Science & Technology											68	2
<i>Civil Engineering</i>											22	1
<i>Industrial Engineering</i>											46	1
Faculty Education							157	12			157	12
<i>Biology</i>							45	4			45	4
<i>Chemistry</i>							42	6			42	6
<i>Physics</i>							29	1			29	1
<i>Mathematics</i>							41	1			41	1

University/Institute/College/Faculty Department	Diploma						Undergraduate Degree						
	New Admission		Readmission		Enrollment		New Admission		Readmission		Enrollment		
	BS	F	BS	F	BS	F	BS	F	BS	F	BS	F	
KOTEBE COLLEGE OF TEACHER EDUC.	168	35	28	5	861	144	60					115	
<i>English</i>			3	1	76	16							
<i>Mathematics</i>	48	14	4		126	23							
<i>Biology</i>			8	2	80	19							
<i>Chemistry</i>	45	13	4	1	112	24							
<i>Geography</i>					79	2							
<i>History</i>			1		62	2							
<i>Ethiopian Languages</i>			2	1	72	22							
<i>Health & Physical Education</i>	43	6	2		141	27	60					115	
<i>Physics</i>	32	2	2		82	2							
<i>Tigrigna</i>			2		31	7							
NAZARETH TECHNICAL COLLEGE									3	1		302	4
<i>Automotive Technology</i>												76	
<i>Construction Technology</i>												78	1
<i>Drafting and Surveying Technology</i>												5	
<i>Electricity/Electronics Technology</i>									1			64	2
<i>Manufacturing Technology</i>									2	1		79	1
BAHIR DAR UNIVERSITY	27	1			27	1	428	23	23	2		1174	59
Bahir Dar Teachers College							405	23	23	2		1133	58
<i>Amharic</i>							44	5				151	23
<i>Biology</i>							46	3	4			153	8
<i>Chemistry</i>							44	3				66	4
<i>English</i>							42	4	3	1		156	8
<i>Geography</i>							44	3	2			151	6
<i>Mathematics</i>							83	2	4			183	3
<i>Physics</i>							36		8			105	
<i>Hisotry</i>							66	3	2	1		168	6
Faculty of Engineering	27	1			27	1	23					41	1
<i>Civil Engineering</i>	27	1			27	1	23					41	1
AWASSA COLLEGE OF TEACHER EDUC.			58	13	1220	182							
<i>English</i>			6	2	220	26							
<i>Amharic</i>			3	1	159	49							
<i>Mathematics</i>			19	4	163	26							
<i>Physics</i>			10	2	123	6							
<i>Biology</i>			8	1	122	22							
<i>Geography</i>			1		102	13							
<i>History</i>			2	1	119	12							
<i>Physical Education</i>					86	9							
<i>Chemistry</i>			9	2	126	19							
JIMMA COLLEGE OF TEACHER EDUCATION	296	47	1	1	383	61							
<i>Oromigna</i>	37	9	1	1	77	15							
<i>English</i>	38	9			59	13							
<i>Geography</i>	29	4			29	4							
<i>History</i>	29	1			29	1							
<i>Biology</i>	38	7			38	7							
<i>Chemistry</i>	31	1			31	1							
<i>Mathematics</i>	37	7			63	11							
<i>Amharic</i>	34	9			34	9							
<i>Physics</i>	23				23								
GONDAR COLLEGE OF TEACHER EDUC.	224	43	60	15	787	153							
<i>Amharic</i>	24	7	2		61	19							
<i>English</i>	53	12	15	5	184	44							
<i>Mathematics</i>	46	8	7	3	154	35							
<i>Biology</i>	20	4	10	2	58	16							
<i>Chemistry</i>	22	4	11	3	113	16							
<i>Physics</i>	20	3	10	1	116	13							
<i>Geography</i>	20	5	3	1	51	8							
<i>History</i>	19		2		50	2							
GRAND TOTAL	1,132	175	167	52	4,437	723	1,836	161	75	8		4,685	307

Graduates from Kiremt Diploma, Undergraduate Degree
by Institution. Department and Sex
2001/02 (1994 E.C.) Academic Year

University/Institute/College/Faculty Department	Diploma		Undergraduate Degree		Total	
	BS	F	BS	F	BS	F
ADDIS ABABA UNIVERSITY			41	1	41	1
College of Social Science			1		1	
<i>History</i>			1		1	
Faculty of Science			38	1	38	1
<i>Biology</i>			15		15	
<i>Mathematics</i>			23	1	23	1
Institute of Language Studies			2		2	
<i>Foreign Language and Literature</i>			2		2	
MAKALLE UNIVERSITY COLLEGE			50	5	50	5
<i>Accounting</i>			6		6	
<i>Soil and Water Conservation</i>			12		12	
<i>Dryland Crop Production</i>			21	3	21	3
<i>Animal and Range Science</i>			11	2	11	2
DEBUB UNIVERSITY	33	1			33	1
Awassa College of Agriculture	33	1			33	1
<i>General Agriculture</i>	33	1			33	1
KOTEBE COLLEGE OF TEACHER EDUCATION	255	42	6		261	42
<i>English</i>	34	4	1		35	4
<i>Mathematics</i>	26	3	5		31	3
<i>Ethiopian Language and Literature</i>	39	13			39	13
<i>Geography</i>	23	3			23	3
<i>History</i>	34	2			34	2
<i>Biology</i>	18	4			18	4
<i>Chemistry</i>	13	4			13	4
<i>Physics</i>	21				21	
<i>Health and Physical Education</i>	17				17	
<i>Tigrigna</i>	30	9			30	9
NAZARTH COLLEGE OF TECHNICAL TEACHER Edu.			24		24	
<i>Automotive Technology</i>			11		11	
<i>Drafting & Sueveying technology</i>			5		5	
<i>Electronics Technology</i>			8		8	
ARBAMINCH WATER TECHNOLOGY INSITITUTE			24		24	
<i>Hydrolic EGINEERING</i>			24		24	
Grand Total	288	43	145	6	433	49